

# Combination Steam Oven, 24", 9 Function

Series 9 | Contemporary

Stainless Steel



Reduce the need for oils and fats with steam cooking. Its compact size makes this perfect to pair with a warming drawer underneath.

- 1.3 cu ft total capacity
- Cooking flexibility with nine oven functions, including five Steam functions, Broil and Convection
- Steam cooking allows you to cook a food in its own juices, to retain nutrients and flavour
- Designed to match aesthetically with companion products such as warming drawers, for flexible cooking configurations

## DIMENSIONS

Height	18 1/16"
Width	23 7/16"
Depth	22 1/8"

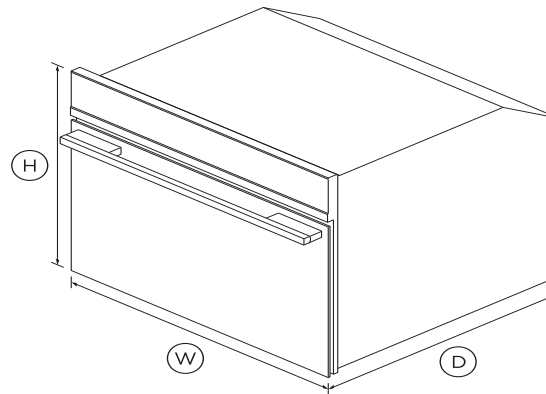

## FEATURES & BENEFITS

### SIZED TO SUIT

This compact 24" Steam Oven can be placed almost anywhere. All Companion products can be installed at a convenient height to suit your kitchen design and preference.

### SIMPLE TO USE

An easy to use, intuitive display shows the time and provides useful information about functions along with a refill alert.

### EASY CLEANING

Cleaning and care of the Steam Oven is simple. After each use, just wipe the smooth stainless steel interior with a dry cloth.

### SAFE & SOUND

The CoolTouch door is safe to touch from the outside, protecting your hands and the surrounding cabinetry.

### EASY INSTALLATION

Plug in and cook straight away. The Steam Oven is easy to install, with no plumbing needed.

### HEALTHY EATING

The Steam Oven allows you to cook food in its own juices to retain nutrients and flavor. With nine oven modes, it doesn't just steam, but also has Broil and Fan functions.

## SPECIFICATIONS

### Accessories

Baking pan	1
Perforated large dish	1
Wire shelf	1
Wired temperature sensor	1

### Accessories (sold separately)

Matching Trim Kit	TK30NDB1
Optional lower trim kit	Part 81662

### Capacity

Shelf positions	3
Total capacity	1.3cu ft

### Cleaning

Easy clean stainless steel	•
----------------------------	---

- Removable water tank •
- Steam clean (oven) •

**Consumption**

Energy usage	<b>141kWh/year</b>
In-use energy carbon	<b>17.4kgCO2e/year</b>

**Controls**

- Audio feedback •
- Automatic cooking/minute •
- Celsius/Fahrenheit •
- Delay start •
- Electronic clock •
- Electronic oven control •
- Food probe •
- Guided cooking by food type •
- Halogen lights •
- Intuitive touchscreen display •

**Functions**

- Broil •
- Convection Broil •
- Number of functions **9**
- Recipe function •
- Ring + broil •
- Steam + ring •
- Steam 100 (100°C / 210°F) •
- Steam 130 (130°C / 265°F) •
- Steam assist •
- Steam clean (oven) •

**Performance**

Broil power	<b>1500W</b>
SteamTechnology	•

**Power requirements**

Amperage	<b>15A</b>
Supply frequency	<b>60Hz</b>
Supply voltage	<b>120/208-120/240V</b>

**Product dimensions**

Depth	<b>22 1/8"</b>
Height	<b>18 1/16"</b>
Width	<b>23 7/16"</b>

**Safety**

- ADA compliant •
- Control panel key lock •
- CoolTouch door •
- Safety thermostat •

SKU 82308

The product dimensions and specifications in this page apply to the specific product and model. Under our policy of continuous improvement, these dimensions and specifications may change at any time. You should therefore check with Fisher & Paykel's Customer Care Centre to ensure this page correctly describes the model currently available. Fisher & Paykel Appliances Ltd 2020

**Where applicable:**

All appliances use energy, and energy usage typically generates carbon emissions. **Fisher & Paykel Appliances' In-use Energy Carbon Emissions Estimate** indicates carbon emissions from a product's in-use energy. This is calculated either annually or per cycle, using the product's market-specific energy label energy consumption data multiplied by the carbon emissions factor for energy in your country or region.

Our In-use Energy Carbon Emissions Estimate is designed to assist customers in making informed purchasing decisions when comparing different Fisher & Paykel products. For example, a heat pump dryer typically has a lower In-use Energy Carbon Emissions Estimate than a vented dryer.

---

Other product downloads available at [fisherpaykel.com](https://fisherpaykel.com)



User Guide EN



Service & Warranty



Installation Guide - Cavity Trim Kit



Installation Guide Companion Products EN



Guide d'installation FR



Specification Guide Combination Steam Oven



Data Sheet Combination Steam Oven



Data Sheet Combination Steam Oven with 30" Trim



Data Sheet Combination Steam Oven with Bottom Trim



**A PEACE OF MIND SALE**

24 Hours 7 Days a Week Customer Support

T 1.888.936.7872 **W**[www.fisherpaykel.com](https://www.fisherpaykel.com)