

Integrated Dishwasher, Tall, Sanitize

Series 7 | Integrated

Panel Ready



Designed to be integrated seamlessly into your cabinetry, this dishwasher delivers extra wash options and Auto Door Open Dry.

- Customize with your own front panel and handle to match your kitchen cabinetry
- Seven wash programs from Heavy to Light, including Auto and 60min
- Dry+, Sanitize and Half Load modifiers provide extra wash options
- Wi-Fi enabled and works with the SmarthQ™ app for remote control and notifications

DIMENSIONS

Height	33 3/4 - 36 1/8"
Width	23 1/2"
Depth	21 13/16"

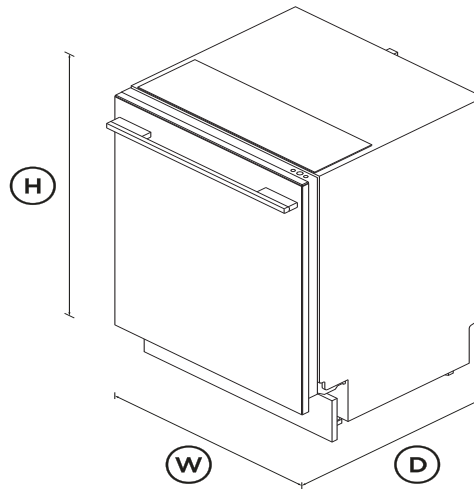

FEATURES & BENEFITS

Seamless integration

Customize your dishwasher with a panel and handle matching your cabinetry, for a seamless finish in your kitchen.

Effortless drying

For beautifully dry dishes every time, this dishwasher features the Auto Door Open Dry function. This function automatically releases excess steam at the end of the cycle, ensuring dishes are immediately ready for use or storage. An innovative air curtain

channels the steam away from the adjacent benchtop, protecting your cabinetry.

A reliable clean

This dishwasher offers seven wash programs including Auto, which automatically senses the optimal wash settings for your dishes. The three-stage filtration system delivers a superior clean, while the rinse aid indicator reminds you to top up for beautifully clean dishes.

Customize Your Wash

The Half Load modifier is perfect for washing a partial load, for faster turnaround of dishes. Sanitize provides extra protection, killing 99.9% of bacteria* in the final rinse, while the Dry+ modifier is great for plastic dishes. *Certified to NSF/ANSI Standard 184

Efficient Performance

With an Energy Star Most Efficient rating, this dishwasher is recognised as among the most energy efficient models on the market. Use the Eco wash program for optimal water and energy consumption, or choose when the cycle begins with Delay Start.

Flexible Loading

Designed to fit 15 place settings with ease, adjustable racks help you to load and care for various items – including a height-adjustable upper basket, and foldable cup holders and tines.

SPECIFICATIONS

Accessories

- Kickstrip

Accessories (sold separately)

Door panel stainless steel	ADDW24TPX
Handle kit Classic	AHCL-DDDW-24X
Handle kit Contemporary	AHS-OBDD-60S
Handle kit Contemporary	AHD5-OBDD-60SX

Handle kit Contemporary	AHD5-OBDD-60SB
Handle kit Contemporary	AHD3-OBDD-60S
Handle kit Professional round	AHP3-DWDD-SX
Handle kit Professional round	AHP3DDDW24BA
Handle kit Professional round	AHP3DDDW24DC

Capacity and loading

Accommodates round plates	12 9/16"
Accommodates round plates	9 13/16"
Adjustable height, foldable	•
Easy lift adjustable upper	•
Fold down tines	•
Fold down wine racks	•
Place settings	15

Consumption

Energy rating	Energy star Most efficient
Energy usage	224kWh/year
In-use energy carbon	27.6kgCO2e/year
Water usage (per wash cycle)	3.2 gal

Controls

Energy saving delay start	•
Internal wash selector	•
Intuitive capacitive touch	•
Keylock	•
Rinse aid indicator light	•
Wi-Fi connectivity	•

Features

Air curtain for bench	•
Auto Door Open Dry	•
Flood protection	•
Half load option	•
Internal tub material	Stainless Steel
Motor type	Asynchronous
ThermoDry system	•
Three-stage filtration system	•

Performance

Noise emissions	46dBA
-----------------	--------------

Power requirements

Amperage	10A
Supply frequency	60Hz
Supply voltage	100 - 120V

Product dimensions

Depth	21 13/16"
Height	33 3/4 - 36 1/8"
Width	23 1/2"

Warranty

Parts and labour	Limited 2 years
------------------	------------------------

Wash Program Modifiers

Dry +	•
Half-load	•
Sanitize	•
Wash modifiers	3

Wash Programs

60 min	•
Auto	•
Eco	•
Heavy	•
Light	•
Medium	•
Rinse	•
Wash programs	7

Water connection

Water pressure	30kPa - 1000 kPa
----------------	-------------------------

SKU	82443
-----	--------------

The product dimensions and specifications in this page apply to the specific product and model. Under our policy of continuous improvement, these dimensions and specifications may change at any time. You should therefore check with Fisher & Paykel's Customer Care Centre to ensure this page correctly describes the model currently available. Fisher & Paykel Appliances Ltd 2020

Where applicable:

All appliances use energy, and energy usage typically generates carbon emissions. **Fisher & Paykel Appliances' In-use Energy Carbon Emissions Estimate** indicates carbon emissions from a product's in-use energy. This is calculated either annually or per cycle, using the product's market-specific energy label energy consumption data multiplied by the carbon emissions factor for energy in your country or region.

Our In-use Energy Carbon Emissions Estimate is designed to assist customers in making informed purchasing decisions when comparing different Fisher & Paykel products. For example, a heat pump dryer typically has a lower In-use Energy Carbon Emissions Estimate than a vented dryer.

Other product downloads available at fisherpaykel.com

- [↓](#) Service & Warranty
- [↓](#) Guide d'utilisation FR
- [↓](#) User Guide Integrated Dishwasher
- [↓](#) Energy Label Dishwasher
- [↓](#) Installation Guide Built Under Dishwasher EN
- [↓](#) Guide d'installation FR
- [↓](#) Preliminary Specification Guide Dishwasher
- [↓](#) Data Sheet Integrated Dishwasher
- [↓](#) Planning Guide Professional Style Dial/Handle Accessories



A PEACE OF MIND SALE

24 Hours 7 Days a Week Customer Support

T 1.888.936.7872 W www.fisherpaykel.com