

# Dual Fuel Range, 48", 5 Burners with Griddle, Self-cleaning, LPG

Series 9 | Professional

Stainless Steel | LPG



With intuitive touchscreen and specialized cooking functions across two ovens, this range is a stand-out addition to your kitchen.

- Guided cooking using your touchscreen makes it simple to cook by food, function or recipe.
- Gas cooktop with a griddle and five burners that deliver up to 19,000 BTU for fast boiling
- 6.9 cu ft total oven capacity across two oven cavities

- Beautiful LED halo-illuminated dials provide information at a glance

## DIMENSIONS

Height	35 3/4 - 36 3/4"
Width	47 7/8"
Depth	29 1/8"

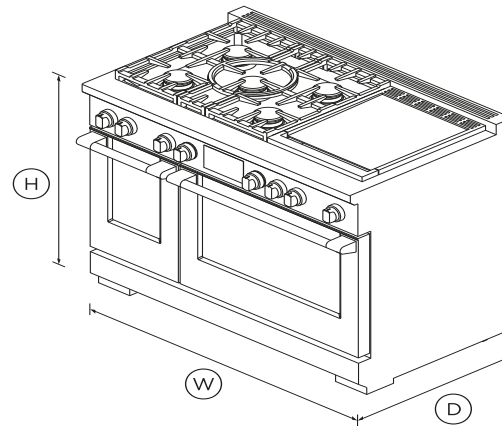

## FEATURES & BENEFITS

### Cook with confidence

Our touchscreen interface provides an intuitive guided cooking experience that helps deliver perfect results, whether you've been cooking all your life or just starting out. Cook with a favorite method, a hero ingredient, or a go-to cooking function or recipe. The screen tilts for improved ergonomics and optimal

visibility while cooking.

### Generous capacity

Two independently operating cavities provide a large total capacity of 4.8 cu. ft. in the main cavity and 2.1 cu. ft. in the secondary. That's enough room for a 32 lb turkey in one oven, and your sides in the other.

### Cooking Flexibility

No matter what you're cooking, you've got the right heat to get perfect results. Each of the 15 oven functions in the main cavity and 11 in the secondary have been extensively researched and carefully designed to cater to a broad range of dishes and cooking styles. The handy food probe helps you monitor your progress.

### Cooktop power

Sealed dual flow burners deliver cooktop power up to 19,000 BTU for seriously fast boiling, and precise 140°F full surface, low temperature cooking with the gentlest of flames.

### Design Quality

This range has craftsmanship in every detail, with real stainless steel, cast-iron grates, and beautifully weighted, halo illuminated dials. Each cavity features incandescent lights and full extension telescopic racks. From the robust legs to the powerful cooktop, this Range is built to last.

### Easy To Clean

The oven features a self-cleaning function and self-clean proof side racks, which don't need to be removed when using this function.

## SPECIFICATIONS

### Accessories

- Adjustable feet covers
- Branded coin end cap

**Accessories (sold separately)**

Square handle option **AH-R48**

**Burner ratings**

Maximum burner power **19000 BTU**  
 Power back left **11500BTU**  
 Power back right **11500BTU**  
 Power centre **19000BTU**  
 Power front left **15000BTU**  
 Power front right **15000BTU**  
 Power griddle **24000BTU**  
 Total cooktop power **96000 BTU**

**Capacity**

Shelf positions (main oven) **5**  
 Shelf positions (second oven) **5**  
 Total capacity (main oven) **4.8cu ft**  
 Total capacity second oven **2.1cu ft**  
 Usable capacity (main oven) **3.8cu ft**

**Cleaning**

Easy clean porcelain basepan •  
 Pyrolytic self-clean •

**Consumption**

Energy usage **470kWh/year**

**Controls**

Dial with illuminated halo •  
 Dual control oven dials •

Electric circuit **4 wire**  
 High resolution display •  
 Metal illuminated dials •  
 Multi-language interface •  
 Precise cooking with food •  
 Recipe and food based •  
 Sabbath mode •  
 Tilting touch screen interface •  
 Wi-Fi connectivity •

**Gas Requirements**

Fitting and pipe **½ NPT, min. ¾" flex line**  
 Supply Pressure (LPG) **11" to 14" W.C**

**Oven features**

Auto re-ignition system •  
 Concealed element •  
 Electronic oven control •  
 Full extension telescopic •  
 Internal light •  
 Titanium coated, illuminated •

**Oven functions**

Air fry •  
 Bake •  
 Classic bake •  
 Clean •  
 Convection Broil •  
 Convection bake •  
 Dehydrate •

Maxi Broil •  
 Number of functions **15**  
 Pastry bake •  
 Pizza bake •  
 Rapid proof •  
 Roast •  
 Slow cook •  
 True convection •  
 Warm •

**Oven performance**

Bake power **4600**  
 Broil **3600W**  
 Main oven - True convection **2500W**

**Power requirements**

Amperage **50A**  
 Rated current **50A**  
 Supply frequency **60Hz**

**Product dimensions**

Depth **29 1/8"**  
 Height **35 3/4 - 36 3/4"**  
 Width **47 7/8"**

**Rangetop features**

Sealed range top •  
 Vent trim included •

**Recommended Back Guards Ventilation**

Combustible situation	<b>BGRV3-3048H</b>
Non combustible situation	<b>BGRV2-3048 / BGRV2-1248</b>
Recommended hood	<b>HCB48-12_N (48"")</b>

**Safety**

ADA compliant	•
---------------	---

**Secondary oven features**

3/4 Extension racks	<b>2</b>
Concealed element	•
Electronic oven control	•
Food probe	•
Internal light	•

**Secondary oven functions**

Air fry	•
Bake	•
Classic bake	•
Convection bake	•
Convection broil	•
Maxi broil	•
Number of secondary oven	<b>11</b>
Pastry bake	•
Pizza bake	•
Rapid proof	•
Roast	•
Warm	•

The product dimensions and specifications in this page apply to the specific product and model. Under our policy of continuous improvement, these dimensions and specifications may change at any time. You should therefore check with Fisher & Paykel's Customer Care Centre to ensure this page correctly describes the model currently available. Fisher & Paykel Appliances Ltd 2020

**Where applicable:**

All appliances use energy, and energy usage typically generates carbon emissions. **Fisher & Paykel Appliances' In-use Energy Carbon Emissions Estimate** indicates carbon emissions from a product's in-use energy. This is calculated either annually or per cycle, using the product's market-specific energy label energy consumption data multiplied by the carbon emissions factor for energy in your country or region.

Our In-use Energy Carbon Emissions Estimate is designed to assist customers in making informed purchasing decisions when comparing different Fisher & Paykel products. For example, a heat pump dryer typically has a lower In-use Energy Carbon Emissions Estimate than a vented dryer.

**Other product downloads available at fisherpaykel.com**

- [↓](#) Guide d'utilisation FR
- [↓](#) Guide d'utilisation FR
- [↓](#) User Guide EN
- [↓](#) Service & Warranty
- [↓](#) Energy Label
- [↓](#) Installation Guide EN
- [↓](#) Guide d'installation FR
- [↓](#) Specification Guide Dual Fuel Range
- [↓](#) Data Sheet Dual Fuel Range
- [↓](#) Planning Guide Dual Fuel Range
- [↓](#) Planning Guide Professional Style Dial/Handle Accessories



**A PEACE OF MIND SALE**

**24 Hours 7 Days a Week Customer Support**

**T 1.888.936.7872 Wwww.fisherpaykel.com**

SKU	81895
-----	-------