

Single DishDrawer™ Dishwasher, Tall, Sanitize

Series 7 | Contemporary

Black



Designed to fit your full-sized dinner plates, this DishDrawer™ can be placed anywhere in your kitchen, for loading dishes with less bending.

- Six wash programs, as well as additional Quick wash, Sanitize and Extra Dry options
- Flexible racking can be folded down to fit bigger dishes
- American Disabilities Act (ADA) compliant, this can be installed at an accessible height for loading and unloading.

DIMENSIONS

| | |
|--------|----------|
| Height | 17 7/8" |
| Width | 23 9/16" |
| Depth | 22 1/2" |

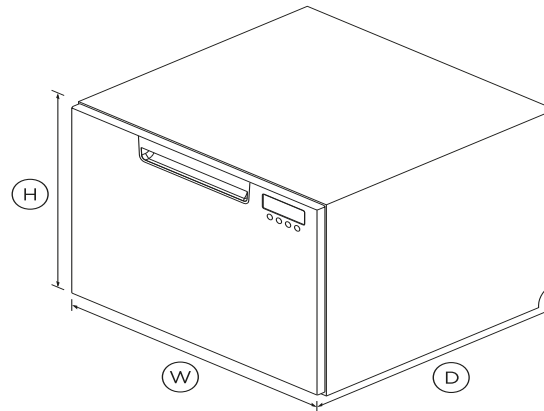

FEATURES & BENEFITS

Ease of use

DishDrawer™ Dishwashers are as easy to open and close as kitchen drawers and can be conveniently positioned at bench height for ease of loading and minimal bending. Flexible racking allows you to make adjustments to fit in a variety of dishes.

Quick, Sanitize and Extra Dry

The Quick wash modifier delivers a faster wash while maintaining performance. The Sanitize option provides extra protection killing 99.9% of bacteria in the final rinse. The Extra Dry setting is

perfect for plastic dishes.

Quiet performer

Running at a very low decibel rate, these DishDrawer™ Dishwashers do their job without making a fuss. The combination of intelligent technology and simple mechanics means greater reliability and excellent wash performance.

Complementary design

DishDrawer™ Dishwashers can be installed in any kitchen space and are designed to match the Fisher & Paykel family of kitchen appliances, with matching handles, premium styling and quality materials.

SPECIFICATIONS

Accessories

- Knife clip and multipurpose

Capacity and loading

| | |
|-----------------------------|--------|
| Accommodates round plates | 12.25" |
| Adjustable height, foldable | • |
| Fold down tines | • |
| Pitch adjustable tines | • |

Consumption

| | |
|------------------------------|-----------------|
| Energy rating | Energy star |
| Energy usage | 151kWh/year |
| In-use energy carbon | 18.6kgCO2e/year |
| Water usage (per wash cycle) | 1.81 gal |

Controls

- Electronic fault/Diagnostic
- End of cycle beeps

- Energy saving delay start •
- Keylock •
- Rinse aid indicator light •

Features

- Fan assisted drying •
- Flow through detergent •
- Quiet operation •
- SmartDrive™ technology •

Performance

Noise emissions **42dBA**

Power requirements

Amperage **5A**
 Electric circuit **3 wire**
 Rated current **15A**
 Supply frequency **60Hz**
 Supply voltage **100 - 120V**

Product dimensions

Depth **22 1/2"**
 Height **17 7/8"**
 Width **23 9/16"**

Safety and compliance

- ADA compliant •

Warranty

Parts and labour **Limited 2 years**

Wash Program Modifiers

- Extra Dry •
- Quick •
- Sanitize •

Wash Programs

- Delicate •
- Fast •
- Heavy •
- Medium •
- Normal eco •
- Rinse •
- Wash programs **6**

Water connection

Water pressure **30kPa - 1000 kPa**
 Water supply **3/8" to suit Male Compression**

SKU **82335**

The product dimensions and specifications in this page apply to the specific product and model. Under our policy of continuous improvement, these dimensions and specifications may change at any time. You should therefore check with Fisher & Paykel's Customer Care Centre to ensure this page correctly describes the model currently available. Fisher & Paykel Appliances Ltd 2020

Where applicable:

All appliances use energy, and energy usage typically generates carbon emissions. **Fisher & Paykel Appliances' In-use Energy Carbon Emissions Estimate** indicates carbon emissions from a product's in-use energy. This is calculated either annually

or per cycle, using the product's market-specific energy label energy consumption data multiplied by the carbon emissions factor for energy in your country or region.

Our In-use Energy Carbon Emissions Estimate is designed to assist customers in making informed purchasing decisions when comparing different Fisher & Paykel products. For example, a heat pump dryer typically has a lower In-use Energy Carbon Emissions Estimate than a vented dryer.

Other product downloads available at fisherpaykel.com



[Guide De Démarrage Rapide FR](#)



[Service & Warranty](#)



[Energy Label Single DishDrawer](#)



[User Guide DishDrawer™ Dishwasher EN](#)



[Installation Guide Single DishDrawer™ Dishwasher EN](#)



[Data Sheet Single DishDrawer™ Dishwasher](#)



A PEACE OF MIND SALE

24 Hours 7 Days a Week Customer Support

T 1.888.936.7872 W www.fisherpaykel.com