

# Combination Steam Oven, 24", 23 Function

Series 11 | Contemporary

Stainless Steel



This Contemporary style oven has 23 functions with additional oven accessories, to effortlessly create healthy and delicious dishes.

- With steam-only cooking functions, convection-only, or a combination of both
- 23 oven functions including Steam, Sous Vide, Air Fry and Vent Bake
- Designed to match companion products such as Vacuum Seal Drawers

- Guided touchscreen cooking makes it simple to cook by food, function or recipe

## DIMENSIONS

Height	23 9/16"
Width	23 7/16"
Depth	22 1/4"

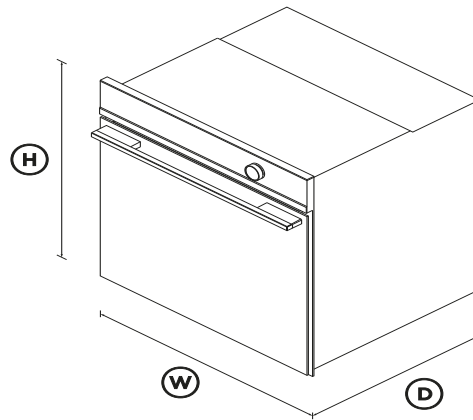

## FEATURES & BENEFITS

### From Steam To Sous Vide

Fine amounts of steam are released with accuracy and precision at a range of temperatures to ensure food is cooked gently and evenly. Perfect for entertaining, you can sous vide proteins such as steak and salmon before guests arrive, and simply sear when ready to serve. The flexibility of timing and accuracy of

temperature control ensure perfect, predictable results every time.

### Gentle And Healthy

Steam functions allow you to cook food in its own juices to retain nutrients, moisture and flavor. With five steam-only cooking functions including Sous Vide, plus four combi-steam functions, this oven lets you enjoy the benefits of flavourful and healthy restaurant-quality meals at home.

### Multi-function flexibility

A true multi-function oven, where the advantages of steam and convection cooking can be explored in full. You have the freedom to choose – whether it's dry heat, moist heat, or a combination of the two, each cooking method creates a unique result. Purchase our Wireless Temperature Sensor accessory and precisely monitor cooking in real time (accessory sold separately).

### Cook With Confidence

Using the large 5" touchscreen interface, you can cook with a favourite method, a hero ingredient, or a go-to cooking function or recipe. Your oven will guide you through the steps, or change the temperature and heat type automatically, depending on your selection.

### Reheat And Restore

Reduce household food waste by reheating foods with steam, which helps to regenerate moisture levels and ensure meals come out fresh and delicious. Use Steam Regenerate to reheat leftover meals such as roasts and risotto, while Crisp Regenerate is perfect for refreshing pastries, breads and pizza.

### Complementary Design

Every detail has been carefully crafted from the finest materials to support a considered kitchen design. This Contemporary style oven has a stylish black finish with stainless steel contrasts, designed to help you achieve a kitchen aesthetic that suits your design style. Pair with a Vacuum Seal Drawer for the ultimate kitchen solution.

### Exceptional convection performance

AeroTech™ circulates heat evenly for a consistent temperature throughout the cavity, while ActiveVent technology ensures optimised moisture levels when using convection functions. Achieve perfect results even when you're using multiple shelves.

**SPECIFICATIONS**

**Accessories**

Broil pan	1
Broil rack	1
Chromed shelf runners	•
Descale solution	2 sachets, Part 580925
Full extension sliding shelves	2 sets
Large solid dish	1
Perforated large dish	1
Perforated small dish	1
Smokeless broil tray	1
Step down wire shelf	1
Wired temperature sensor	1

**Capacity**

Shelf positions	6
Total capacity	3cu ft
Usable capacity	2.5cu ft

**Cleaning**

Acid resistant graphite enamel	•
Descale cycle	•
Drying cycle	•
Removable oven door	•
Removable oven door inner	•

Removable shelf runners	•
Removable water tank	•
Steam clean (oven)	•

**Consumption**

Energy usage	240kWh/year
In-use energy carbon	29.6kgCO2e/year

**Controls**

Adjustable audio and display	•
Automatic cooking/minute	•
Automatic pre-set	•
Celsius/Fahrenheit	•
Delay start	•
Dial with illuminated halo	•
Electronic clock	•
Electronic oven control	•
Food probe	•
Guided cooking by food type	•
Halogen lights	•
Intuitive touchscreen display	•
Multi-language display	UK English, US English,
Sabbath mode with Star K	•
Soft close doors	•
Wi-Fi connectivity	•

**Functions**

Aero Bake	•
Aero Broil	•
Air fry	•

Bake	•
Broil	•
Classic bake	•
Crisp regenerate	•
Number of functions	23
Pastry Bake	•
Pizza bake	•
Roast	•
Slow cook	•
Sous vide	•
Steam	•
Steam clean (oven)	•
Steam defrost	•
Steam proof	•
Steam regenerate	•
True Aero	•
True Aero + High steam	•
True Aero + Low steam	•
True Aero + Medium steam	•
Vent bake	•
Warm	•

**Performance**

ActiveVent™ system	•
AeroTech™ technology	•
Automatic rapid pre-heat	•
SteamTechnology	•
Temperature range	95°F -445°F
Whisper quiet cooking	•

**Power requirements**

Amperage	16.6 - 19.4A
Supply voltage	208 - 240V

**Product dimensions**

Depth	22 1/4"
Height	23 9/16"
Width	23 7/16"

**Safety**

ADA compliant	•
Balanced oven door	•
Catalytic venting system	•
Control panel key lock	•
CoolTouch door	•
Non-tip shelves	•

SKU	82542
-----	-------

making informed purchasing decisions when comparing different Fisher & Paykel products. For example, a heat pump dryer typically has a lower In-use Energy Carbon Emissions Estimate than a vented dryer.

**Other product downloads available at fisherpaykel.com**

- [↓](#) Service & Warranty
- [↓](#) Energy Label Combination Steam Oven
- [↓](#) Guide d'utilisation FR
- [↓](#) User Guide Steam Oven EN
- [↓](#) Guide d'installation FR
- [↓](#) Installation Guide Combination Steam Oven EN
- [↓](#) Preliminary Specification Guide Steam Oven
- [↓](#) Data Sheet Combination Steam Oven

**A PEACE OF MIND SALE****24 Hours 7 Days a Week Customer Support****T 1.888.936.7872 Wwww.fisherpaykel.com**

The product dimensions and specifications in this page apply to the specific product and model. Under our policy of continuous improvement, these dimensions and specifications may change at any time. You should therefore check with Fisher & Paykel's Customer Care Centre to ensure this page correctly describes the model currently available. Fisher & Paykel Appliances Ltd 2020

**Where applicable:**

All appliances use energy, and energy usage typically generates carbon emissions. **Fisher & Paykel Appliances' In-use Energy Carbon Emissions Estimate** indicates carbon emissions from a product's in-use energy. This is calculated either annually or per cycle, using the product's market-specific energy label energy consumption data multiplied by the carbon emissions factor for energy in your country or region.

Our In-use Energy Carbon Emissions Estimate is designed to assist customers in