

Double DishDrawer™ Dishwasher, Tall, Sanitize

Series 11 | Professional

Stainless Steel



Boasting bold Professional styling including a stainless steel interior, each drawer operates independently, for flexible washing

- Eight wash cycles from Heavy to Light, including Auto, 60min and Glassware
- Tall top drawer fits full-size dinner plates up to 12 1/4 inches, with flexible racking for large cookware
- Wi-Fi capability and a SmartHQ™ app for remote control and notifications

DIMENSIONS

| | |
|--------|--------------|
| Height | 34 - 36 3/8" |
| Width | 23 9/16" |
| Depth | 22 9/16" |

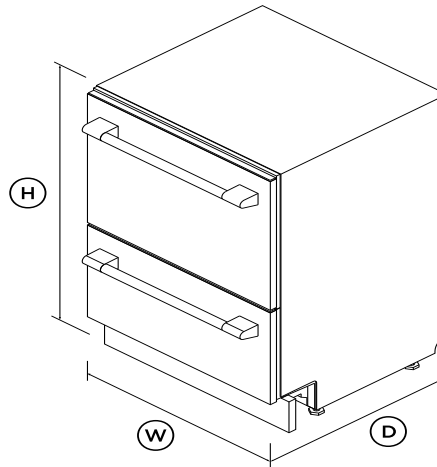

FEATURES & BENEFITS

Ease of use

DishDrawer™ Dishwashers are beautiful to use with soft-close drawers. The tall top drawer fits your larger plates and dishes up to 12 1/4 inches, while the bottom drawer is ideal for small washes. Flexible racking includes height-adjustable cup racks and wine glass supports.

Design quality

Every detail has been carefully crafted using quality materials, from the easy-to-clean stainless steel interior to the spray arm

sensor that detects jams for increased wash confidence.

Complementary Design

With distinctive, bold styling, this DishDrawer™ Dishwasher is designed to match the Fisher & Paykel Professional style family of appliances.

True half load

Both drawers fit a true half load. Each drawer operates independently, so you can wash one load while stacking the other drawer, or wash simultaneously on separate cycles.

Flexible Wash Options

Eight wash programs including Auto, 60min and Glassware, while modifiers such as Sanitize, Dry+ and Quiet provide added wash flexibility. The Quiet wash modifier reduces the noise on some cycles while maintaining performance – perfect for late night washing.

Efficient performance

With a Energy Star Most Efficient rating, this DishDrawer™ Dishwasher is recognised amongst the most energy efficient models on the market.

SPECIFICATIONS

Accessories

- Cutlery basket
- Kickstrip
- Knife clip and multipurpose

Capacity and loading

| | |
|-----------------------------|---------------------------|
| Accommodates round plates | 12.25" (top) 11" (bottom) |
| Adjustable height, foldable | • |
| Fold down tines | • |
| Pitch adjustable tines | • |
| Place settings | 14 |

Wine glass supports with •

Consumption

| | |
|------------------------------|-----------------------------------|
| Energy rating | Energy star Most efficient |
| Energy usage | 225kWh/year |
| In-use energy carbon | 27.7kgCO2e/year |
| Water usage (per wash cycle) | 3.1 gal running both tubs |

Controls

- Electronic fault/Diagnostic •
- End of cycle beeps •
- Energy saving delay start •
- Internal wash selector •
- Intuitive capacitive touch •
- Keylock •
- Rinse aid indicator light •
- Spray arm sensing •
- Wi-Fi connectivity •

Features

- Fan assisted drying •
- Flow through detergent •
- Internal tub material **Stainless steel**
- Quiet operation •
- SmartDrive™ technology •
- Soft close drawer •

Performance

Noise on standard cycle top **44dBA**

Power requirements

| | |
|------------------|-------------------|
| Amperage | 10A |
| Electric circuit | 3 wire |
| Rated current | 15A |
| Supply frequency | 60Hz |
| Supply voltage | 100 - 120V |

Product dimensions

| | |
|--------|---------------------|
| Depth | 22 9/16" |
| Height | 34 - 36 3/8" |
| Width | 23 9/16" |

Warranty

Parts and labour **Limited 2 years**

Wash Program Modifiers

- Dry + •
- Quiet •
- Sanitize •
- Wash modifiers **3**

Wash Programs

- 60 min •
- Auto •
- Eco •
- Glassware •
- Heavy •
- Light •
- Medium •

- Rinse •
- Wash programs **8**

Water connection

| | |
|----------------------------|--------------------------------------|
| Inlet water temperature | 140°F |
| Supplied hose to suit 3/8" | • |
| Water pressure | 30kPa - 1000 kPa |
| Water supply | 3/8" to suit Male Compression |

SKU **82397**

The product dimensions and specifications in this page apply to the specific product and model. Under our policy of continuous improvement, these dimensions and specifications may change at any time. You should therefore check with Fisher & Paykel's Customer Care Centre to ensure this page correctly describes the model currently available. Fisher & Paykel Appliances Ltd 2020

Where applicable:

All appliances use energy, and energy usage typically generates carbon emissions. **Fisher & Paykel Appliances' In-use Energy Carbon Emissions Estimate** indicates carbon emissions from a product's in-use energy. This is calculated either annually or per cycle, using the product's market-specific energy label energy consumption data multiplied by the carbon emissions factor for energy in your country or region.

Our In-use Energy Carbon Emissions Estimate is designed to assist customers in making informed purchasing decisions when comparing different Fisher & Paykel products. For example, a heat pump dryer typically has a lower In-use Energy Carbon Emissions Estimate than a vented dryer.

Other product downloads available at fisherpaykel.com



Wash Program Data Sheet EN



Service & Warranty



Energy Label Double DishDrawer™ Dishwasher



User Guide DishDrawer™ Dishwasher EN



Guide d'utilisation FR



Guide d'installation FR



Installation Guide (EN)



Datasheet



A PEACE OF MIND SALE

24 Hours 7 Days a Week Customer Support

T 1.888.936.7872 W www.fisherpaykel.com