

Combination Steam Oven, 30", 23 Function

Series 7 | Contemporary

Stainless Steel



Our Combination Steam Oven is designed for the home chef, helping to effortlessly create healthy and delicious dishes. It pairs seamlessly with companion products such as the Vacuum Seal Drawer or Warming Drawer.

- With steam-only cooking functions, convection-only, or a combination of both
- 23 oven functions including Steam, Sous Vide, Air Fry and Vent Bake
- Designed to match companion products such as Vacuum Seal Drawers

- Guided cooking capability offers helpful tips for different food types

DIMENSIONS

Height	23 9/16"
Width	29 15/16"
Depth	22 1/4"

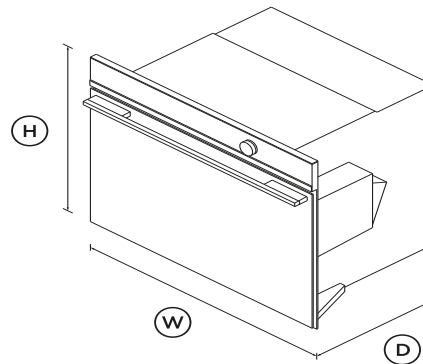

SPECIFICATIONS

Consumption

Energy usage	234kWh/year
In-use energy carbon	28.9kgCO ₂ e/year

Product dimensions

Depth	22 1/4"
Height	23 9/16"
Width	29 15/16"

SKU	84722
-----	-------

The product dimensions and specifications in this page apply to the specific product and model. Under our policy of continuous improvement, these dimensions and specifications may change at any time. You should therefore check with Fisher & Paykel's Customer Care Centre to ensure this page correctly describes the model currently available. Fisher & Paykel Appliances Ltd 2020

Where applicable:

All appliances use energy, and energy usage typically generates carbon emissions. **Fisher & Paykel Appliances' In-use Energy Carbon Emissions Estimate** indicates carbon emissions from a product's in-use energy. This is calculated either annually or per cycle, using the product's market-specific energy label energy consumption data multiplied by the carbon emissions factor for energy in your country or region.

Our In-use Energy Carbon Emissions Estimate is designed to assist customers in making informed purchasing decisions when comparing different Fisher & Paykel products. For example, a heat pump dryer typically has a lower In-use Energy Carbon Emissions Estimate than a vented dryer.

Other product downloads available at fisherpaykel.com



Service & Warranty



Energy Label Oven



Planning Guide - Contemporary 30" Built-in Ovens and Companions



A PEACE OF MIND SALE

24 Hours 7 Days a Week Customer Support

T 1.888.936.7872 [Wwww.fisherpaykel.com](https://www.fisherpaykel.com)