

Wall Range Hood, 30"

Series 5 | Professional

Stainless Steel



Striking design that pairs well with any appliances in our Professional range. Fast, efficient extraction of steam and odors.

- With four fan speeds, select the perfect extraction rate for your cooking
- With dishwasher-safe stainless steel baffle filters
- Powerful 600CFM maximum airflow

DIMENSIONS

Height	12"
Width	29 7/8"
Depth	23"

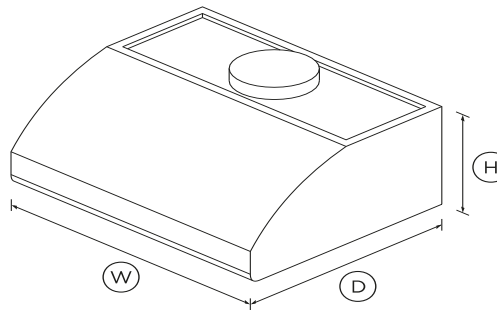

FEATURES & BENEFITS

Design Quality

The high quality finish, premium grade stainless steel and robust product design combine to deliver an efficient wall hood. This vent hood can also be installed within cabinetry.

Simple Controls

A single on/off button makes the hood easy to use. A slider control lets you precisely adjust the fan speed up or down. Two level halogen lighting effectively illuminates the cooking surface.

Easy Cleaning

Filters effectively trap grease particles during extraction. They are easy to remove and dishwasher safe, or can be cleaned by hand in hot soapy water.

Complementary Design

The stainless steel finish is designed to match the rest of the Fisher & Paykel kitchen appliance family.

SPECIFICATIONS

Fan ratings

Maximum sound rating	71dBA
----------------------	-------

Performance

Extraction type	Surface
Fan speeds	4
Filter type	Stainless Steel Baffle

Power requirements

Rated current	15A
Supply frequency	60Hz
Supply voltage	120V

Product dimensions

Depth	23"
Height	12"
Width	29 7/8"

Product information

Control type	Rotary switch
--------------	---------------

Ventilation features

Light type	Halogen
------------	---------

Warranty

Parts and labour	Limited 2 years
------------------	-----------------

SKU	50145
-----	-------

The product dimensions and specifications in this page apply to the specific product and model. Under our policy of continuous improvement, these dimensions and specifications may change at any time. You should therefore check with Fisher & Paykel's Customer Care Centre to ensure this page correctly describes the model currently available. Fisher & Paykel Appliances Ltd 2020

Where applicable:

All appliances use energy, and energy usage typically generates carbon emissions. **Fisher & Paykel Appliances' In-use Energy Carbon Emissions Estimate** indicates carbon emissions from a product's in-use energy. This is calculated either annually or per cycle, using the product's market-specific energy label energy consumption data multiplied by the carbon emissions factor for energy in your country or region.

Our In-use Energy Carbon Emissions Estimate is designed to assist customers in making informed purchasing decisions when comparing different Fisher & Paykel products. For example, a heat pump dryer typically has a lower In-use Energy Carbon Emissions Estimate than a vented dryer.

Other product downloads available at fisherpaykel.com[User Guide EN](#)[Guide d'utilisation FR](#)[Service & Warranty](#)[Installation Guide EN](#)[Guide d'installation FR](#)**A PEACE OF MIND SALE****24 Hours 7 Days a Week Customer Support****T 1.888.936.7872 W www.fisherpaykel.com**