

Double DishDrawer™ Dishwasher, Tall, Sanitize

Series 7 | Contemporary

Black



Doing the dishes got easier. Load one drawer while the other washes – with the top drawer fitting your large dinner plates easily.

- Six wash programs, as well as additional Quick wash, Sanitize and Extra Dry options
- Flexible racking can be folded down to fit bigger dishes

DIMENSIONS

Height	34 - 36 3/8"
Width	23 9/16"
Depth	22 9/16"

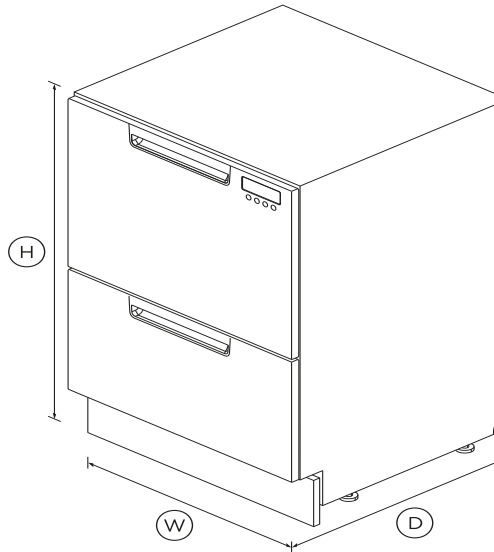

FEATURES & BENEFITS

Ease of use

DishDrawer™ Dishwashers are as easy to open and close as kitchen drawers and can be conveniently positioned at bench height for ease of loading and minimal bending. Flexible racking allows you to make adjustments to fit in a variety of dishes.

Independent Wash

With the ability to use both drawers independently and select different wash programs the DishDrawer™ Dishwasher can wash everything from fine glass and crystal to heavily soiled pots and

pans.

Quick, Sanitize and Extra Dry options

The Quick wash modifier delivers a faster wash while maintaining performance. The Sanitize option provides extra protection killing 99.9% of bacteria in the final rinse. The Extra Dry setting is perfect for plastic dishes.

Quiet performer

Running at a very low decibel rating, these DishDrawer™ dishwashers do their job without making a fuss. The combination of intelligent technology and simple mechanics means greater reliability and excellent wash performance.

SPECIFICATIONS

Accessories

- Cutlery basket
- Kickstrip
- Knife clip and multipurpose

Accessories (sold separately)

Handle kit Contemporary **Part number 81674**

Capacity and loading

Accommodates round plates	12.25" (top) 11" (bottom)
Adjustable height, foldable	•
Fold down tines	•
Pitch adjustable tines	•
Place settings	14

Consumption

Energy usage	265kWh/year
In-use energy carbon	32.7kgCO2e/year

Water usage (per wash cycle) **3.44 gal running both tubs**

Controls

- Electronic fault/Diagnostic •
- End of cycle beeps •
- Energy saving delay start •
- Keylock •
- Rinse aid indicator light •

Features

- Fan assisted drying •
- Flow through detergent •
- Quiet operation •
- SmartDrive™ technology •

Performance

Noise on standard cycle top **42dBA**

Power requirements

Amperage **10A**
 Electric circuit **3 wire**
 Rated current **15A**
 Supply frequency **60Hz**
 Supply voltage **100 - 120V**

Product dimensions

Depth **22 9/16"**
 Height **34 - 36 3/8"**
 Width **23 9/16"**

Warranty

Parts and labour **Limited 2 years**

Wash Program Modifiers

Extra Dry •
 Quick •
 Sanitize •
 Wash modifiers **3**

Wash Programs

Delicate •
 Fast •
 Heavy •
 Medium •
 Normal eco •
 Rinse •
 Wash programs **6**

Water connection

Water pressure **30kPa - 1000 kPa**
 Water supply **3/8" to suit Male Compression**

SKU **82330**

The product dimensions and specifications in this page apply to the specific product and model. Under our policy of continuous improvement, these dimensions and specifications may change at any time. You should therefore check with Fisher & Paykel's Customer Care Centre to ensure this page correctly describes the model currently available. Fisher & Paykel Appliances Ltd 2020

Where applicable:

All appliances use energy, and energy usage typically generates carbon emissions. **Fisher & Paykel Appliances' In-use Energy Carbon Emissions Estimate** indicates carbon emissions from a product's in-use energy. This is calculated either annually or per cycle, using the product's market-specific energy label energy consumption data multiplied by the carbon emissions factor for energy in your country or region.

Our In-use Energy Carbon Emissions Estimate is designed to assist customers in making informed purchasing decisions when comparing different Fisher & Paykel products. For example, a heat pump dryer typically has a lower In-use Energy Carbon Emissions Estimate than a vented dryer.

Other product downloads available at fisherpaykel.com



[Guide De Démarrage Rapide FR](#)



[Service & Warranty](#)



[Energy Label Double DishDrawer™ Dishwasher](#)



[User Guide DishDrawer™ Dishwasher EN](#)



[Installation Guide Double DishDrawer™ Dishwasher EN](#)



[Guide d'installation FR](#)



[Installation Guide Double DishDrawer™ Dishwasher](#)



[Specification Guide Double DishDrawer™ Dishwasher](#)



[Data Sheet Double DishDrawer™ Dishwasher](#)



A PEACE OF MIND SALE

24 Hours 7 Days a Week Customer Support

T 1.888.936.7872 [Wwww.fisherpaykel.com](http://www.fisherpaykel.com)