

Wall Range Hood, 24", Box Chimney

Series 7 | Contemporary

Stainless Steel and Glass



The wall chimney range hood has contemporary styling, extracting steam, grease and cooking odors quietly and efficiently.

- With four fan speeds, select the perfect extraction rate for your cooking
- Energy-efficient LED lighting to illuminate your cooking surface
- Powerful 600CFM maximum airflow

DIMENSIONS

Height	23 3/4 - 41 1/16"
Width	23 9/16"
Depth	19 11/16"

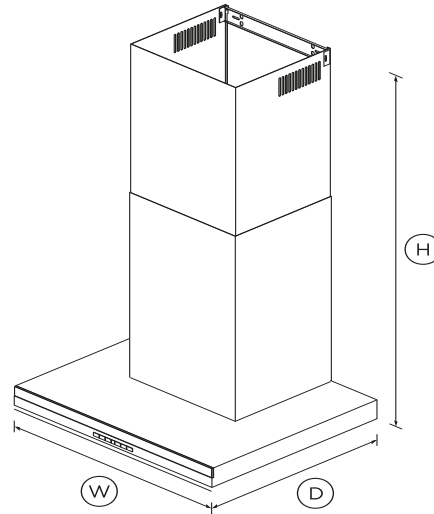

FEATURES & BENEFITS

Quiet And Effective

This vent hood features four fan speeds providing powerful extraction to quickly remove odours and steam. Odors can linger in the kitchen well after cooking is finished so the timer keeps the vent hood working for up to 15 minutes before automatically turning off.

Simple Controls

This Fisher & Paykel chimney range hood features a sleek and easy to use soft-touch control panel. This range hood's LED

lights provide bright, warm, energy efficient lighting ensuring the entire cooktop surface is illuminated.

Easy Cleaning

The black glass and stainless steel finish is easily wiped clean. Multi-layered, dishwasher safe filters trap grease effectively and can easily be removed for cleaning.

Complementary Design

This wall chimney vent hood's sleek stainless steel finish will complement any contemporary kitchen and is designed to match the rest of Fisher & Paykel's kitchen appliance family.

SPECIFICATIONS

Accessories (sold separately)

Chimney extension	791774
Light bulb	792579
Recirculation carbon filter	791772
Recirculation diverter	792580

Fan ratings

Maximum sound rating	67dBA
Speed 3 sound rating	63dBA

Installation and cleaning

Air outlet size	6"
Dishwasher safe filters	2
Ducted	Top extraction
Recirculation	Optional - top extraction
Stainless steel filter cover	•
Two piece height adjustable	•

Performance

Extraction type	Surface
Fan speeds	4
Filter type	Mesh
Number of filters	2

Power requirements

Rated current	5.2A
Supply frequency	60Hz
Supply voltage	120V
Total Power	542W

Product dimensions

Depth	19 11/16"
Height	23 3/4 - 41 1/16"
Width	23 9/16"

Product information

Control type	soft-touch button
--------------	--------------------------

Ventilation features

Light type	LED
Timer function	•

Warranty

Parts and labour	2 years
------------------	----------------

SKU	50082
-----	--------------

The product dimensions and specifications in this page apply to the specific product and model. Under our policy of continuous improvement, these dimensions and specifications may change at any time. You should therefore check with Fisher & Paykel's Customer Care Centre to ensure this page correctly describes the model currently available. Fisher & Paykel Appliances Ltd 2020

Where applicable:

All appliances use energy, and energy usage typically generates carbon emissions. **Fisher & Paykel Appliances' In-use Energy Carbon Emissions Estimate** indicates carbon emissions from a product's in-use energy. This is calculated either annually or per cycle, using the product's market-specific energy label energy consumption data multiplied by the carbon emissions factor for energy in your country or region.

Our In-use Energy Carbon Emissions Estimate is designed to assist customers in making informed purchasing decisions when comparing different Fisher & Paykel products. For example, a heat pump dryer typically has a lower In-use Energy Carbon Emissions Estimate than a vented dryer.

Other product downloads available at fisherpaykel.com

- [↓](#) Service & Warranty
- [↓](#) Installation & User Guide EN / Guide d'installation et guide d'utilisation FR
- [↓](#) Installation Guide
- [↓](#) Guide D'Installation



A PEACE OF MIND SALE

24 Hours 7 Days a Week Customer Support

T 1.888.936.7872 W www.fisherpaykel.com