

Oven, 30", 17 Function, Self-cleaning

Series 9 | Contemporary

Stainless Steel



With contemporary styling, advanced cook functions and touchscreen, this large capacity oven is a highlight of our collection

- Guided cooking using your touchscreen makes it simple to cook by food, function or recipe.
- 4.1 cu ft total capacity, with 17 oven functions including Aero™ Pastry and Roast, Air Fry and Dehydrate
- Non-tip, full extension sliding shelves for safe removal of hot dishes
- Accessories include food probe, smokeless grill tray, and more

DIMENSIONS

Height	27 3/16"
Width	29 15/16"
Depth	23 15/16"

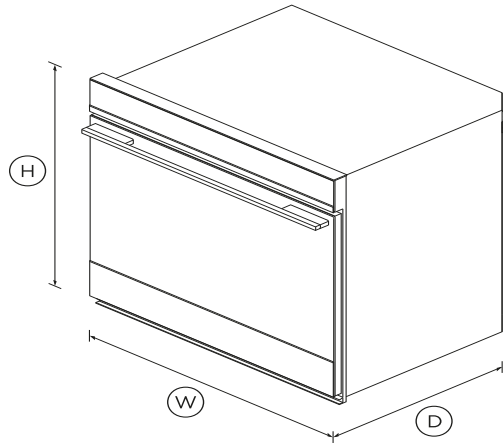

FEATURES & BENEFITS

Cook With Confidence

Our touchscreen interface provides an intuitive guided cooking experience that helps deliver perfect results, whether you've been cooking all your life or just starting out. Cook with a favorite method, a hero ingredient, or a go-to cooking function or recipe.

Generous capacity

With its 4.1 cu ft total capacity, you can create several perfectly

cooked dishes at once using multiple shelves.

Multi-function flexibility

The cooking functions have each been tailored, tested, tweaked and perfected to ensure that no matter what you're cooking, you've got the right heat to match. Purchase our Wireless Temperature Sensor accessory and precisely monitor cooking in real time (accessory sold separately).

Exceptional Performance

AeroTech circulates heat evenly for a consistent temperature throughout the cavity, helping you ensure perfect results even when cooking on multiple shelves.

Self-Cleaning

Our self-clean technology breaks down food residue at a very high temperature, leaving a light ash that's easily removed with a damp cloth. The enamel coated side racks don't need to be removed when using this function.

Design freedom

Available in an elegant black or a stylish black with stainless steel, this oven is designed to fit seamlessly into your kitchen. Premium materials and detailing to support a cohesive, considered kitchen design.

SPECIFICATIONS

Accessories

Broil rack	1 set
Full extension sliding shelves	3 sets
Perforated baking tray	1
Roasting pan	1
Smokeless broil tray	1
Wired temperature sensor	1

Capacity

Shelf positions	8
Total capacity	4.1cu ft

Cleaning

Acid resistant graphite enamel	•
Removable oven door	•
Removable shelf runners	•
Removable water tank	•

Consumption

Energy usage	402kWh/year
In-use energy carbon	49.6kgCO2e/year

Controls

Adjustable audio and display	•
Automatic cooking/minute	•
Automatic pre-set	•
Celsius/Fahrenheit	•
Electronic clock	•
Electronic oven control	•
Food probe	•
Guided cooking by food type	•
Intuitive touchscreen display	•
Multi-language display	UK English, US English,
Sabbath mode with Star K	•
Soft close doors	•
Wi-Fi connectivity	•

Functions

Aero Bake	•
-----------	---

Bake	•
Broil	•
Classic bake	•
Dehydrate	•
Maxi Broil	•
Number of functions	17
Pastry Bake	•
Pizza bake	•
Rapid proof	•
Roast	•
Self-clean	•
Slow cook	•
Vent bake	•
Warm	•

Performance

AeroTech™ technology	•
Automatic rapid pre-heat	•
Broil power	4400W
Number of passes on Maxi	12
Number of passes on broil	10
Whisper quiet cooking	•

Power requirements

Amperage	16.6 - 19.4A
Supply voltage	208 / 240V

Product dimensions

Depth	23 15/16"
Height	27 3/16"

Width	29 15/16"
-------	-----------

Safety

ADA compliant	•
Balanced oven door	•
Catalytic venting system	•
Control panel key lock	•
CoolTouch door	•
Non-tip shelves	•

SKU	82262
-----	-------

The product dimensions and specifications in this page apply to the specific product and model. Under our policy of continuous improvement, these dimensions and specifications may change at any time. You should therefore check with Fisher & Paykel's Customer Care Centre to ensure this page correctly describes the model currently available. Fisher & Paykel Appliances Ltd 2020

Where applicable:

All appliances use energy, and energy usage typically generates carbon emissions. **Fisher & Paykel Appliances' In-use Energy Carbon Emissions Estimate** indicates carbon emissions from a product's in-use energy. This is calculated either annually or per cycle, using the product's market-specific energy label energy consumption data multiplied by the carbon emissions factor for energy in your country or region.

Our In-use Energy Carbon Emissions Estimate is designed to assist customers in making informed purchasing decisions when comparing different Fisher & Paykel products. For example, a heat pump dryer typically has a lower In-use Energy Carbon Emissions Estimate than a vented dryer.

Other product downloads available at fisherpaykel.com

- [↓](#) User Guide
- [↓](#) Guide d'utilisation FR
- [↓](#) Energy Label
- [↓](#) Service & Warranty
- [↓](#) Energy Label Oven
- [↓](#) Installation Guide
- [↓](#) Guide d'installation FR
- [↓](#) Installation Guide EN / Guide d'installation FR
- [↓](#) Specification Guide Oven
- [↓](#) Data Sheet Oven



A PEACE OF MIND SALE

24 Hours 7 Days a Week Customer Support

T 1.888.936.7872 W www.fisherpaykel.com