

Integrated Double DishDrawer™ Dishwasher, Tall, Sanitize

Series 9 | Integrated

Panel Ready



Doing the dishes got easier. Load one drawer while the other washes - with the top drawer fitting your large dinner plates easily.

- Knock to pause function is perfect if you miss a dish
- Six wash programs, as well as additional Quick wash, Sanitize and Extra Dry options
- Built-in water softener improves wash performance by reducing unwanted minerals in the water

- Customize with your own kitchen cabinetry or purchase our stainless steel door panel accessory

DIMENSIONS

Height	34 - 36 3/8"
Width	23 9/16"
Depth	22 1/2"

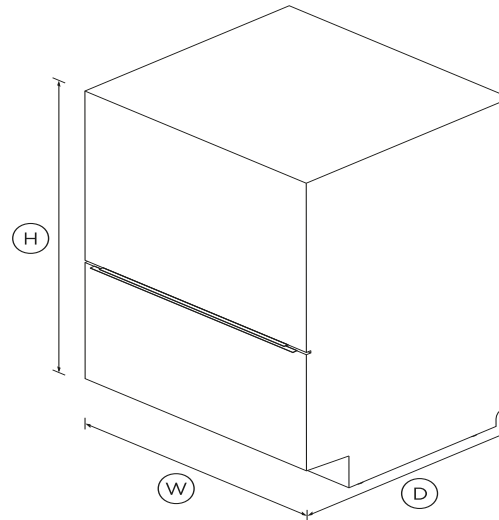

SPECIFICATIONS

Accessories

- Kickstrip
- Knife clip and multipurpose

Accessories (sold separately)

Door panel stainless steel	ADDD24DTPX
Handle kit Classic	AHCL-DDDW-24X
Handle kit Contemporary	AHS-OBDD-60S
Handle kit Contemporary	AHD5-OBDD-60SX
Handle kit Contemporary	AHD5-OBDD-60SB
Handle kit Contemporary	AHD3-OBDD-60S
Handle kit Professional round	AHP3-DWDD-SX
Handle kit Professional round	AHP3DDDW24BA
Handle kit Professional round	AHP3DDDW24DC

Capacity and loading

Accommodates round plates	12.25" (top) 11" (bottom)
Adjustable height, foldable	•
Fold down tines	•
Pitch adjustable tines	•
Place settings	14
Place settings per drawer	7

Consumption

Energy usage	286kWh/year
In-use energy carbon	35.3kgCO2e/year
Water usage (per wash cycle)	3.6 gal running both tubs

Controls

- Electronic fault/Diagnostic
- End of cycle beeps
- Energy saving delay start
- Internal wash selector
- Keylock
- Knock to pause

- Rinse aid indicator light •
- Wi-Fi connectivity •

Features

- Built-in water softener •
- Fan assisted drying •
- Flow through detergent •
- Motor type **BLDC**
- Quiet operation •
- SmartDrive™ technology •

Performance

Noise on standard cycle top **43dBA**

Power requirements

Amperage **10A**
 Electric circuit **3 wire**
 Rated current **15A**
 Supply frequency **60Hz**
 Supply voltage **100 - 120V**

Product dimensions

Depth **22 1/2"**
 Height **34 - 36 3/8"**
 Width **23 9/16"**

Warranty

Parts and labour **Limited 2 years**

Wash Program Modifiers

- Extra Dry •
- Quick •
- Sanitize •

Wash Programs

- Delicate •
- Eco •
- Fast •
- Heavy •
- Medium •
- Rinse •
- Wash programs **6**

Water connection

- Supplied hose to suit 3/8" •
- Water pressure **100kPa - 1000kPa**
- Water supply **3/8" to suit Male Compression**

SKU **82337**

The product dimensions and specifications in this page apply to the specific product and model. Under our policy of continuous improvement, these dimensions and specifications may change at any time. You should therefore check with Fisher & Paykel's Customer Care Centre to ensure this page correctly describes the model currently available. Fisher & Paykel Appliances Ltd 2020

Where applicable:

All appliances use energy, and energy usage typically generates carbon emissions. **Fisher & Paykel Appliances' In-use Energy Carbon Emissions Estimate** indicates carbon emissions from a product's in-use energy. This is calculated either annually or per cycle, using the product's market-specific energy label energy consumption data multiplied by the carbon emissions factor for energy in your country or region.

Our In-use Energy Carbon Emissions Estimate is designed to assist customers in making informed purchasing decisions when comparing different Fisher & Paykel products. For example, a heat pump dryer typically has a lower In-use Energy Carbon Emissions Estimate than a vented dryer.

Other product downloads available at fisherpaykel.com



Quick Start Guide EN



Guide De Démarrage Rapide FR



Service & Warranty



Energy Label Integrated Double DishDrawer™ Dishwasher



User Guide DishDrawer™ Dishwasher EN



Guide d'installation FR



Installation Guide Double DishDrawer™ Dishwasher EN



Data Sheet Integrated Double DishDrawer™ Dishwasher



Planning Guide Professional Style Dial/Handle Accessories



A PEACE OF MIND SALE

24 Hours 7 Days a Week Customer Support

T 1.888.936.7872 W www.fisherpaykel.com