

# Freestanding French Door Refrigerator Freezer, 32", 17 cu ft

Series 7 | Contemporary

Stainless Steel | French hinge



Designed for those who need plenty of flexible space for their cold and frozen food storage, with a stylish stainless steel finish.

- ActiveSmart™ helps keep food fresher for longer
- Bottom freezer drawer
- Brushed metal handles

## DIMENSIONS

Height	67 3/4"
Width	31 1/8"
Depth	27 3/8"

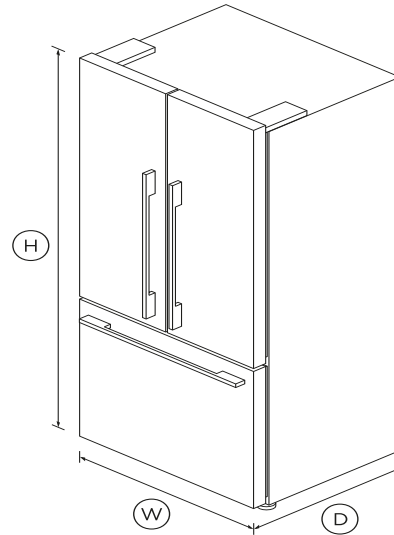

## FEATURES & BENEFITS

### Activesmart™ Foodcare

ActiveSmart™ technology understands that the refrigerator door is the most opened in the house. It constantly adjust temperature, airflow and humidity, maintaining an optimum environment and helping keep food fresher for longer.

### Design quality

Our refrigerators are designed and built using quality materials. We use real stainless steel on our refrigerators and solid glass for shelving.

### Easy Cleaning

No more permanent dirty marks with our EZKleen feature for stainless steel refrigerators. Anti-fingerprint coating means you simply wipe clean any marks. Spill-safe secure glass shelves easily capture any drips or leaks.

### Clever energy

Your refrigerator adapts to daily use by cooling and defrosting only when needed. This means your refrigerator uses the energy it needs without compromising on food care.

### Complementary Design

With their premium handle styling and stainless steel finish, our refrigerators are designed to match the rest of Fisher & Paykel's kitchen appliance family.

## SPECIFICATIONS

### Accessories (sold separately)

Handle kit Contemporary	25376
-------------------------	-------

### Capacity

Total gross capacity	16.9cu ft
Volume freezer	4.8cu ft
Volume refrigerator	12.1cu ft

### Consumption

Energy usage	448kWh/year
In-use energy carbon	55.2kgCO2e/year

### Features

Adjustable door shelves	8
Adjustable glass shelves	3
Covered door shelves	2

Door alarm	•
Fruit and vegetable bins	2
LED lighting	•
SmartTouch control panel	•
Stackable bottle holders	4
Wi-Fi connectivity	•

**Freezer Features**

Bottle chill	•
Fast freeze	•
Ice trays	1

**Performance**

ActiveSmart™ Foodcare	•
Adaptive defrost	•
Frost free freezer	•
Humidity control system	•
Sabbath mode	•

**Product dimensions**

Depth	27 3/8"
Height	67 3/4"
Minimum air clearance - at rear	1 3/16"
Minimum air clearance - each	1 3/16"
Width	31 1/8"

**Warranty**

Parts and labour	2 years
Sealed system parts and labor	additional 3 years

SKU 26283

The product dimensions and specifications in this page apply to the specific product and model. Under our policy of continuous improvement, these dimensions and specifications may change at any time. You should therefore check with Fisher & Paykel's Customer Care Centre to ensure this page correctly describes the model currently available. Fisher & Paykel Appliances Ltd 2020

**Where applicable:**

All appliances use energy, and energy usage typically generates carbon emissions. **Fisher & Paykel Appliances' In-use Energy Carbon Emissions Estimate** indicates carbon emissions from a product's in-use energy. This is calculated either annually or per cycle, using the product's market-specific energy label energy consumption data multiplied by the carbon emissions factor for energy in your country or region.

Our In-use Energy Carbon Emissions Estimate is designed to assist customers in making informed purchasing decisions when comparing different Fisher & Paykel products. For example, a heat pump dryer typically has a lower In-use Energy Carbon Emissions Estimate than a vented dryer.



**A PEACE OF MIND SALE**

24 Hours 7 Days a Week Customer Support

T 1.888.936.7872 [Wwww.fisherpaykel.com](http://www.fisherpaykel.com)