

Oven, 30", 17 Function, Self-cleaning

Series 9 | Contemporary

Stainless Steel



A highlight of the Fisher & Paykel collection, this Series 9 oven with touchscreen guided cooking helps to ensure every dish is cooked to perfection.

- Touchscreen guided cooking capability offers helpful tips for different food types as well as full recipes
- 4.1 cu ft total capacity, with 17 oven functions including Pastry Bake, Roast, Air Fry and Dehydrate
- Pyrolytic self-cleaning function breaks down food residue for an easy clean
- Moisture level control with ActiveVent technology

DIMENSIONS

Height	27 3/16"
Width	29 15/16"
Depth	23 15/16"

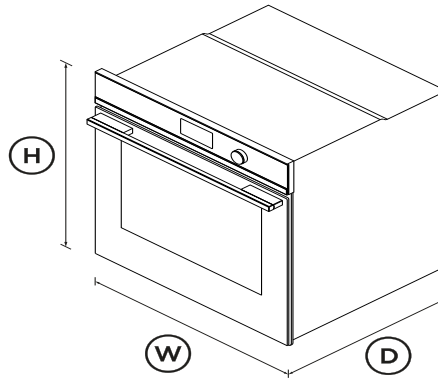

FEATURES & BENEFITS

Cook with confidence

Using the large 5" touchscreen interface, you can cook with a favorite method, a hero ingredient, or a go-to cooking function or recipe. Your oven will guide you through the steps, or change the temperature and heat type automatically, depending on your selection.

Generous Capacity

With an exceptional 4.1 cu ft total capacity, you can create

several perfectly cooked dishes at once using multiple shelves.

Multi-Function Flexibility

Each function has been tailored, tested and perfected to ensure that no matter what you're cooking, you've got the right heat to match. Purchase our Wireless Temperature Sensor accessory and precisely monitor cooking in real time (accessory sold separately).

Exceptional Performance

AeroTech™ circulates heat evenly for a consistent temperature throughout the cavity, helping you ensure perfect results even when cooking on multiple shelves.

Self-Cleaning

Pyrolytic self-clean breaks down food residue at a very high temperature, leaving a light ash that's easily removed with a damp cloth. The enamel coated side racks don't need to be removed when using this function.

Design Freedom

Designed to fit seamlessly into your kitchen, this built-in oven features premium materials and detailing to support a cohesive, considered kitchen design.

Safe and sound

The CoolTouch door features triple glazing and a cooling system that ensures it's safe to touch from the outside - protecting both your hands and the surrounding cabinetry.

SPECIFICATIONS

Accessories

Broil grid	1
Broil pan	1
Broil rack	1
Pyrolytic proof shelf runners	•
Wired temperature sensor	1

Capacity	
Total capacity	4.1cu ft

Cleaning	
Acid resistant graphite enamel	•
Pyrolytic proof shelf runners	•
Pyrolytic self-clean	•
Removable oven door	•
Removable shelf runners	•

Consumption	
Energy usage	402kWh/year
In-use energy carbon	49.6kgCO2e/year

Controls	
Adjustable audio and display	•
Audio feedback	•
Automatic cooking/minute	•
Automatic pre-set	•
Celsius/Fahrenheit	•
Delay start	•
Electronic clock	•
Electronic oven control	•
Food probe	•
Guided cooking by food type	•
Halogen lights	•
Intuitive touchscreen display	•
Multi-language display	UK English, US English,
Sabbath mode with Star K	•
True convection oven	•

Wi-Fi connectivity •

Functions

- Aero Bake •
- Aero Broil •
- Air fry •
- Bake •
- Broil •
- Classic bake •
- Dehydrate •
- Maxi Broil •
- Number of functions **17**
- Pastry Bake •
- Pizza bake •
- Rapid proof •
- Roast •
- Self-clean •
- Slow cook •
- True Aero •
- Vent bake •
- Warm •

Performance

- ActiveVent™ system •
- AeroTech™ technology •
- Automatic rapid pre-heat •
- Broil power **4400W**

Power requirements

Amperage **16.6 - 19.4A**

Supply frequency **60Hz**
Supply voltage **208 - 240VV**

Product dimensions

Depth **23 15/16"**
Height **27 3/16"**
Width **29 15/16"**

Safety

- ADA compliant •
- Balanced oven door •
- Catalytic venting system •
- Control panel key lock •
- CoolTouch door •
- Non-tip shelves •
- Safety thermostat •

Warranty

Parts and labour **2 years**

SKU **82536**

The product dimensions and specifications in this page apply to the specific product and model. Under our policy of continuous improvement, these dimensions and specifications may change at any time. You should therefore check with Fisher & Paykel's Customer Care Centre to ensure this page correctly describes the model currently available. Fisher & Paykel Appliances Ltd 2020

Where applicable:

All appliances use energy, and energy usage typically generates carbon emissions. **Fisher & Paykel Appliances' In-use Energy Carbon Emissions Estimate** indicates

carbon emissions from a product's in-use energy. This is calculated either annually or per cycle, using the product's market-specific energy label energy consumption data multiplied by the carbon emissions factor for energy in your country or region.

Our In-use Energy Carbon Emissions Estimate is designed to assist customers in making informed purchasing decisions when comparing different Fisher & Paykel products. For example, a heat pump dryer typically has a lower In-use Energy Carbon Emissions Estimate than a vented dryer.

Other product downloads available at fisherpaykel.com

- [↓](#) Energy Label Oven
- [↓](#) Service & Warranty
- [↓](#) User Guide Oven EN
- [↓](#) User Guide Oven FR
- [↓](#) User Guide Oven SP
- [↓](#) Installation Guide Wall Oven EN
- [↓](#) Data Sheet Oven
- [↓](#) Planning Guide - Contemporary 30" Built-in Ovens and Companions



A PEACE OF MIND SALE

24 Hours 7 Days a Week Customer Support

T 1.888.936.7872 W www.fisherpaykel.com