

Gas Range, 24", 4 Burners

Series 5 | Contemporary

Stainless Steel | Natural gas



Perfect for compact kitchens, but with plenty of room to cook a large family roast and all the sides.

- Four burner gas cooktop, with wok burner
- Gas oven with 2.5 cu.ft total capacity and four oven functions including Defrost and Convection Bake

DIMENSIONS

Height	35 7/16 - 36 7/32"
Width	23 7/8"
Depth	24 3/32"

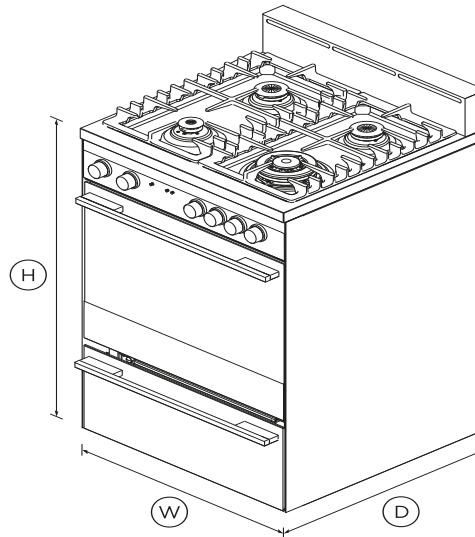

FEATURES & BENEFITS

Cooking Flexibility

This freestanding gas range has four functions with pre-set temperatures, including Bake, Broil and Convection Bake allowing you to use a variety of cooking styles.

Sized to suit

Designed for multi-shelf cooking, this freestanding range provides 2.5 cu ft of total capacity, enough room for a large family roast.

Precise Control

The consistent flame and heat distribution of the gas burners combined with highly responsive dials offer precise heat control. Perfect a slow simmer for sauces or an intense heat for searing steaks.

Easy cleaning

Cleaning is quick and simple. The cooktop is easy to clean as it is made from a single piece of stainless steel that contains spills. The oven door and its inner pane of glass can be removed for easy cleaning.

Safe And Sound

The double glazed door keeps the heat on the inside, protecting your hands and surrounding cabinetry. The gas cooktops flame failure safety device automatically turns off the gas if the flame is accidentally extinguished.

Complementary Design

With their black reflective glass and stainless steel finish, our freestanding cookers are designed to match the rest of Fisher & Paykel's kitchen appliance family.

SPECIFICATIONS

Accessories

Step down wire shelf

Accessories (sold separately)

Kick strip, stainless steel

KICKOR36X1

Burner ratings

Auxiliary burner (natural gas)

3500BTU

Semi-rapid burner (natural)

6000BTU

Triple ring wok burner (natural)

12000BTU

CapacityShelf positions **3****Cleaning**

- Acid resistant graphite enamel •
- Removable oven door •
- Removable oven door inner •

Controls

- Automatic cooking/minute •
- Electronic clock •

Oven features

- Cooling Fan Warning Light •
- Electronic ignition •

Oven functions

- Bake •
- Broil •
- Convection bake •
- Defrost •
- Grill •

Oven performanceBroil **8500 BTU****Power requirements**

Amperage **0.1A**

Supply frequency **60Hz**

Product dimensions

Depth **24 3/32"**

Height **35 7/16 - 36 7/32"**

Width **23 7/8"**

Rangetop features

- Cast iron grates •
- LPG/Natural gas compatible •

Rangetop PerformanceNumber of burners **4****Safety**

- ADA compliant •
- Advanced cooling system •
- Anti-tilt bracket •
- Door and cavity cooling •
- Glazed door •
- Non-tip shelves •

SKU **81554**

The product dimensions and specifications in this page apply to the specific product and model. Under our policy of continuous improvement, these dimensions and specifications may change at any time. You should therefore check with Fisher & Paykel's Customer Care Centre to ensure this page correctly describes the model currently available. Fisher & Paykel Appliances Ltd 2020

Where applicable:

All appliances use energy, and energy usage typically generates carbon emissions. **Fisher & Paykel Appliances' In-use Energy Carbon Emissions Estimate** indicates carbon emissions from a product's in-use energy. This is calculated either annually or per cycle, using the product's market-specific energy label energy consumption data multiplied by the carbon emissions factor for energy in your country or region.

Our In-use Energy Carbon Emissions Estimate is designed to assist customers in making informed purchasing decisions when comparing different Fisher & Paykel products. For example, a heat pump dryer typically has a lower In-use Energy Carbon Emissions Estimate than a vented dryer.

Other product downloads available at fisherpaykel.com



User Guide EN



Service & Warranty



Installation Guide EN



Data Sheet Gas Range



A PEACE OF MIND SALE

24 Hours 7 Days a Week Customer Support

T 1.888.936.7872 **W**www.fisherpaykel.com