

569L Series 7 French Door Refrigerator Freezer, Ice & Water

Contemporary



Our largest capacity French Door model has intuitive, flexible storage space in a striking black stainless steel finish.

- ActiveSmart™ technology helps keep food fresher for longer by constantly maintaining the ideal temperature.
- Spacious bottom freezer with full extension drawer gives easy access to frozen goods

DIMENSIONS

Height 1790 mm

Width 900 mm
Depth 695 mm

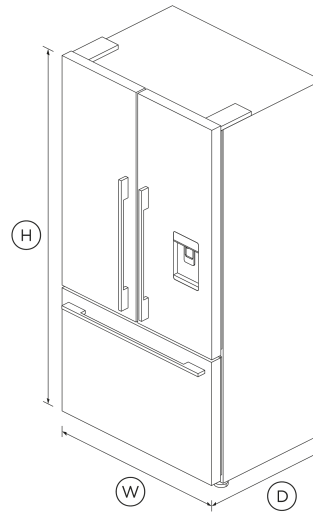

Your fruit and veges need different environments. The humidity control slides in each storage bin create a microclimate that helps keep food fresher for longer.

Ice maker

Fresh ice is always available for you in a dedicated freezer bin. Simply turn it off to free up freezer space or, during busy times, boost ice production by up to 30%.

Design quality

Our refrigerators are designed and built using the best quality materials. We use real stainless steel, and solid glass for the interior shelving.

Simple Storage

This refrigerator is designed to make it simple for you to store, access and remove food. Storage bins give you full access inside when they're pulled open and can be easily removed to clean. Our flexible shelving also gives you more storage options.

Clever Energy

Your refrigerator adapts to daily use by cooling and defrosting only when needed. This means it uses the energy it needs without compromising on food care.

FEATURES & BENEFITS

ActiveSmart™ Foodcare

ActiveSmart™ Foodcare learns how you live. It's the technology that understands how you use your refrigerator and adjusts the temperature, airflow and humidity inside to help keep food fresher for longer.

Easy To Clean

No more dirty marks with our EZKleen feature for stainless steel fridges. Anti-fingerprint coating means you simply wipe clean any finger marks. Spill-safe secure glass shelves easily capture any drips or leaks.

Humidity Control

SPECIFICATIONS

Accessories (sold separately)

Water filter replacement **847200 - FWC3**

Capacity

Total gross capacity **614 L**
Volume **569 L**
Volume freezer **152 L**

Volume refrigerator **417 L**

Connected Features

Cyber security updates until **04 / 03 / 2028**

Consumption

Energy rating **3.5 star**

Energy usage **433kWh/year (IEC 62552-2015), 453kWh/year (AS/NZS 4474.2:2009)**

In-use energy carbon emissions estimate **264.2kgCO2e/year (IEC 62552-2015), 276.4kgCO2e/year (AS/NZS 4474.2:2009)**

Features

- Adjustable door shelves **6**
- Adjustable glass shelves **2**
- Cantilevered shelves **2**
- Covered door shelves **2**
- Door alarm **•**
- Fruit and vegetable bins **2**
- LED lighting **•**
- Smart appliance **•**
- SmartTouch control panel **•**
- Stackable bottle holders **4**
- Ultra slim water dispenser **•**

Freezer Features

- Automatic ice maker **•**
- Bottle chill **•**
- Door alarm **•**
- Fast freeze **•**
- Ice bin and scoop **•**
- Ice Boost **•**
- Large plastic bins **•**
- LED Lighting **•**
- Small plastic bins **•**

Performance

- ActiveSmart™ Foodcare **•**
- Adaptive defrost **•**
- Frost free freezer **•**
- Humidity control system **•**
- Inverter controlled compressor **•**
- R600a refrigerant **•**
- Sabbath mode **•**

Power requirements

Rated current **10 A**

Supply frequency **50 Hz**

Supply voltage **230 V**

Product dimensions

Depth **695 mm**

Depth (including handles) **730 mm**

Height **1790 mm**

Height to top of cabinet **1790 mm**

Minimum air clearance - each side **20 mm**

Minimum air clearance - on top **50 mm**

Width **900 mm**

SKU **26493**

The product dimensions and specifications in this page apply to the specific product and model. Under our policy of continuous improvement, these dimensions and specifications may change at any time. You should therefore check with Fisher & Paykel's Customer Care Centre to ensure this page correctly describes the model currently available. © Fisher & Paykel Appliances Ltd 2020

Other product downloads available at fisherpaykel.com

- [↓](#) DWG
- [↓](#) DXF
- [↓](#) Archicad
- [↓](#) Data Sheet (English)
- [↓](#) Energy Label
- [↓](#) Water Filter Replacement Instructions - Parts 847200 and 847201 (English)
- [↓](#) Installation Guide (English)
- [↓](#) Revit
- [↓](#) Rhino
- [↓](#) SketchUp
- [↓](#) User Guide (English)
- [↓](#) Installation & User Guide (English)

Where applicable:

All appliances use energy, and energy usage typically generates carbon emissions. **Fisher & Paykel Appliances' In-use Energy Carbon Emissions Estimate** indicates carbon emissions from a product's in-use energy. This is calculated either annually or per cycle, using the product's market-specific energy label energy consumption data multiplied by the carbon emissions factor for energy in your country or region.

Our In-use Energy Carbon Emissions Estimate is designed to assist customers in making informed purchasing decisions when comparing different Fisher & Paykel products. For example, a heat pump dryer typically has a lower In-use Energy Carbon Emissions Estimate than a vented dryer.



A PEACE OF MIND SALE
24 Hours 7 Days a Week Customer Support
T 1300 650 590 W www.fisherpaykel.com