

# 24" Series 7 Contemporary Self-Cleaning Oven, 11 Function

Contemporary



- Wi-Fi enabled for remote control and notifications through the SmartHQ™ app

## DIMENSIONS

Height	23 9/16 "
Width	23 7/16 "
Depth	22 1/4 "

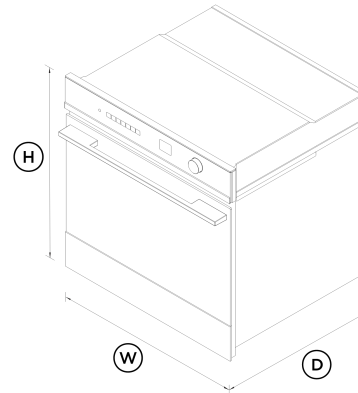

## FEATURES & BENEFITS

### Multi-Function Flexibility

Each function has been perfected to ensure that no matter what you're cooking, you've got the right heat to match. This built-in oven has 11 functions including Pizza Bake, Roast, Slow Cook and Air Fry, allowing you to use a variety of cooking styles.

### Generous Capacity

With an exceptional 3 cu ft total capacity, you can create several perfectly cooked dishes at once using multiple shelves.

### Cook With Confidence

The intuitive 2.4" screen provides an intuitive guided cooking experience that helps to deliver perfect results, whether you've been cooking all your life or are just starting out. Cook by food type and allow your oven to guide you through steps, or change temperature and heat type automatically, depending on your selection.

### Exceptional Performance

Our unique cooking technologies were developed to deliver perfect results. ActiveVent ensures optimized moisture levels, while AeroTech™ circulates heat evenly for a consistent temperature.

### Self-Cleaning

Pyrolytic self-clean breaks down food residue at a very high temperature, leaving a light ash that's easily removed with a damp cloth.

### Design Freedom

Designed to fit seamlessly into your kitchen, this built-in oven features premium materials and detailing to support a cohesive, considered kitchen design.

### Safe And Sound

The CoolTouch door features triple glazing and a cooling system that ensures it's safe to touch from the outside - protecting both your hands and the surrounding cabinetry.

## SPECIFICATIONS

### Accessories (included)

Broil pan	1
Broil rack	1

With beautiful Contemporary styling and generous capacity, this built-in oven helps to ensure that every dish you create is cooked to perfection.

- 3 cu ft total capacity with 11 oven functions including Pizza Bake, Roast and Air Fry
- Moisture level control with ActiveVent technology
- Pyrolytic self-cleaning function breaks down food residue for an easy clean

Chromed shelf runners	•
Step down wire shelf	1
Wire shelf	1

**Capacity**

Shelf positions	6
Total capacity	3 cu ft
Usable capacity	2.5 cu ft

**Cleaning**

Acid resistant graphite enamel	•
Pyrolytic self-clean	•
Removable oven door	•
Removable oven door inner glass	•
Removable side ladders	•

**Controls**

Adjustable audio and display settings	•
Automatic cooking/minute timer	•
Automatic pre-set temperatures	•
Celsius/Fahrenheit temperature	•
Delay start	•
Electronic clock	•
Electronic oven control	•
Guided cooking by food type and recipes	•
Internal Light	•
Multi-language display	UK English
Sabbath mode with Star K certification	•

Smart appliance	•
Soft close doors	•
True convection oven	•
Turned stainless steel dials with illuminated halos	•

**Functions**

Aero Broil	•
Aero™ Bake	•
Air fry	•
Bake	•
Broil	•
Number of functions	11
Pizza bake	•
Pyrolytic self-clean	•
Roast	•
Slow cook	•
True Aero	•
Vent bake	•

**Performance**

ActiveVent™ system	•
AeroTech™ technology	•
Automatic rapid pre-heat	•
Temperature range	95°F - 540°F
Whisper Quiet Cooking	•

**Power Requirements**

Amperage	16.6 - 19.4 A
----------	---------------

Supply frequency	60 Hz
Supply voltage	208 - 240 V

**Product Dimensions**

Depth	22 1/4 "
Height	23 9/16 "
Width	23 7/16 "

**Safety**

ADA compliant	•
Balanced oven door	•
Catalytic venting system	•
Control panel key lock	•
CoolTouch door	•
Non-tip shelves	•
Safety thermostat	•

SKU	82753
-----	-------

The product dimensions and specifications in this page apply to the specific product and model. Under our policy of continuous improvement, these dimensions and specifications may change at any time. You should therefore check with Fisher & Paykel's Customer Care Centre to ensure this page correctly describes the model currently available. © Fisher & Paykel Appliances Ltd 2020

Other product downloads available at [fisherpaykel.com](https://fisherpaykel.com)

- [↓ DWG](#)
- [↓ DXF](#)
- [↓ Archicad](#)
- [↓ Data Sheet \(English\)](#)
- [↓ Installation Guide \(English\)](#)
- [↓ Installation Guide \(English\)](#)
- [↓ Installation Guide \(Canadian French\)](#)
- [↓ Installation Guide \(Canadian French\)](#)
- [↓ Installation Guide \(Spanish\)](#)
- [↓ Revit](#)
- [↓ Rhino](#)
- [↓ Right To Repair Declaration \(English, Canadian French\)](#)
- [↓ SketchUp](#)
- [↓ User Guide \(English\)](#)
- [↓ User Guide \(Canadian French\)](#)
- [↓ User Guide \(Spanish\)](#)



## A PEACE OF MIND SALE

24 Hours 7 Days a Week Customer Support

T 1.888.936.7872 W [www.fisherpaykel.com](http://www.fisherpaykel.com)

### Where applicable:

All appliances use energy, and energy usage typically generates carbon emissions. **Fisher & Paykel Appliances' In-use Energy Carbon Emissions Estimate** indicates carbon emissions from a product's in-use energy. This is calculated either annually or per cycle, using the product's market-specific energy label energy consumption data multiplied by the carbon emissions factor for energy in your country or region.

Our In-use Energy Carbon Emissions Estimate is designed to assist customers in making informed purchasing decisions when comparing different Fisher & Paykel products. For example, a heat pump dryer typically has a lower In-use Energy Carbon Emissions Estimate than a vented dryer.