

# 413L Series 5 Refrigerator Freezer

Contemporary



With stylish contemporary design and generous, flexible storage for all your chilled and frozen foods.

- ActiveSmart™ technology helps keep food fresher for longer by constantly maintaining the ideal temperature.
- Spacious bottom freezer with easy-slide internal drawers to separate storage

## DIMENSIONS

Height	1715 mm
Width	680 mm

Depth

695 mm

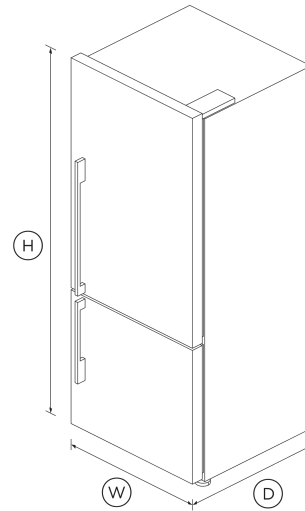

Your fridge adapts to daily use by cooling and defrosting only when needed. This means your fridge uses the energy it needs without compromising on food care.

### Easy Cleaning

No more permanent dirty marks with our EZKleen feature for stainless steel refrigerators. Anti-fingerprint coating means you simply wipe clean any marks. Spill-safe secure glass shelves easily capture any drips or leaks.

### Design quality

Our refrigerators are designed and built using quality materials. We use real stainless steel on our refrigerators and solid glass for shelving.

### Humidity Control

Your fruit and veges need different environments. The humidity control slides in each storage bin create a microclimate that helps keep food fresher for longer.

## FEATURES & BENEFITS

### Activesmart™ Foodcare

ActiveSmart™ Foodcare learns how you live. It's technology which understands how you use your refrigerator and adjusts temperature, airflow and humidity inside to help keep food fresher for longer.

### Simple storage

This refrigerator is designed to make it simple for you to store, access and remove food. Storage bins give you full access inside when they're pulled open and can be easily removed to clean. Our flexible shelving also gives you more storage options.

### Clever Energy

## SPECIFICATIONS

### Capacity

Total gross capacity	442 L
Volume	413 L
Volume freezer	119 L
Volume refrigerator	294 L

### Connected Features

Cyber security updates until	04 / 03 / 2028
------------------------------	----------------

### Consumption

Energy rating	3 star
---------------	--------

Energy usage **428kWh/year**  
 In-use energy carbon emissions estimate **261.2kgCO2e/year**

Inverter controlled compressor •

**Features**

Adjustable door shelves **4**  
 Adjustable glass shelves **4**  
 Covered door shelves **2**  
 Door alarm •  
 Fruit and vegetable bins **2**  
 LED lighting •  
 Single bottle holders **2**  
 Smart appliance •  
 SmartTouch control panel •

**Power requirements**

Rated current **10 A**  
 Supply frequency **50 Hz**  
 Supply voltage **230 V**

**Freezer Features**

Bottle chill •  
 Door alarm •  
 Fast freeze •  
 Ice trays **2**  
 Large plastic bins •  
 Slide Out Pastry Tray •  
 Small plastic bins •

**Product dimensions**

Depth **695 mm**  
 Depth (including handles) **730 mm**  
 Height **1715 mm**  
 Height to top of cabinet **1715 mm**  
 Minimum air clearance - each side **20 mm**  
 Minimum air clearance - on top **50 mm**  
 Width **680 mm**

SKU **26385**

The product dimensions and specifications in this page apply to the specific product and model. Under our policy of continuous improvement, these dimensions and specifications may change at any time. You should therefore check with Fisher & Paykel's Customer Care Centre to ensure this page correctly describes the model currently available. © Fisher & Paykel Appliances Ltd 2020

**Performance**

ActiveSmart™ Foodcare •  
 Adaptive defrost •  
 Frost free freezer •  
 Humidity control system •

**Other product downloads available at fisherpaykel.com**

[↓](#) DWG

- [↓](#) DXF
- [↓](#) Archicad
- [↓](#) Data Sheet (English)
- [↓](#) Energy Label
- [↓](#) Energy Label
- [↓](#) Installation Guide (English)
- [↓](#) Revit
- [↓](#) SketchUp

**Where applicable:**

All appliances use energy, and energy usage typically generates carbon emissions. **Fisher & Paykel Appliances' In-use Energy Carbon Emissions Estimate** indicates carbon emissions from a product's in-use energy. This is calculated either annually or per cycle, using the product's market-specific energy label energy consumption data multiplied by the carbon emissions factor for energy in your country or region.

Our In-use Energy Carbon Emissions Estimate is designed to assist customers in making informed purchasing decisions when comparing different Fisher & Paykel products. For example, a heat pump dryer typically has a lower In-use Energy Carbon Emissions Estimate than a vented dryer.



**A PEACE OF MIND SALE**  
**24 Hours 7 Days a Week Customer Support**  
 T 1300 650 590 [Wwww.fisherpaykel.com](http://www.fisherpaykel.com)