

FISHER & PAYKEL

FABRIC CARE SOLUTION

FABRIC CARE CABINET INSTALLATION

FC1260HG1 and FC1260H1 models

INSTALLATION GUIDE

CN

COMPONENTS REQUIRED

TOOLS

Supplied

- 6mm Allen key
- Spanner

Not supplied

- Box cutter
- Level

PARTS

Supplied

- 1x 6mm allen key
- 1x Spanner
- 1x Drip tray
- 1x Garment hanger box
- 1x Shoerack

Supplied (not required*)

- 1x Communication cable

*Not required for single product installation.

ACCESSING YOUR PRODUCT SPECIFICATIONS



For full product, cabinetry and service specifications, refer to the Planning Guide. To access the Planning Guide, scan the QR code or visit fisherpaykel.com/cn/zh_CN/specify. Search by appliance type, product name or model code.

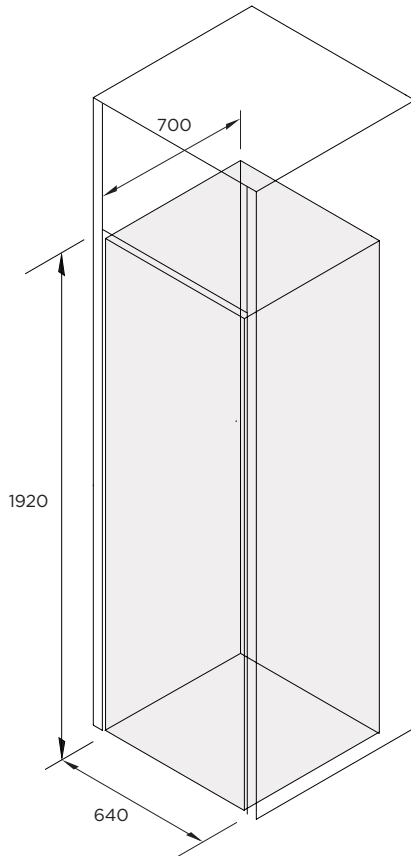

PRIOR TO INSTALLATION



fisherpaykel.com/cn/zh_CN/specify

1. Ensure cabinetry and servicing specifications have been met and clearances have been considered.

Refer to the Planning Guide for details.



2. Ensure floor is level and clear and a finished return has been created.



3. Ensure power will remain accessible following install to allow access for any future product maintenance.

Service holes should be smooth with gromets installed where required.

Refer to the services section of the Planning Guide for more details.

UNPACK



1. Cut the straps and the line printed on the back of the carton. Cut to the nearest corner and remove sleeve. Discard braces, corner posts and sleeve.

Remove packaging and accessories from inside cabinet.



2. Dispose of packaging responsibly.



3. Protect flooring before positioning cabinet as close to the installation location as possible, ensuring enough working room is left available.

LEVEL CABINET

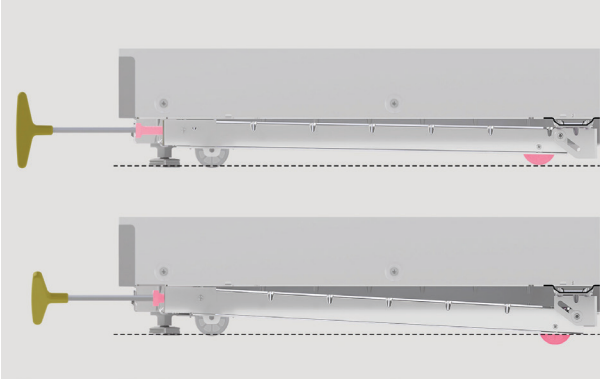

1. Open the cabinet door and lower the rear wheel using the supplied Allen key.

Rotate clockwise to lower the wheel and counter-clockwise to raise.

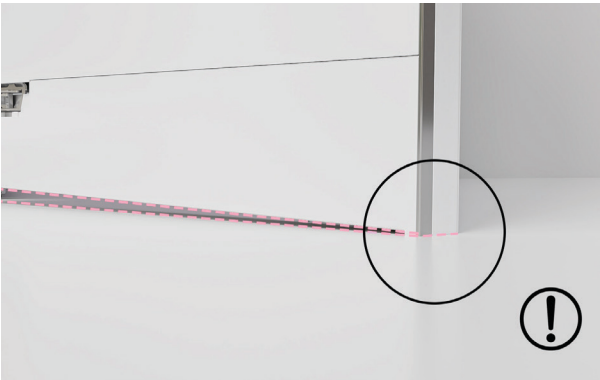

2. When adjusting the wheel, ensure front of the door doesn't damage the floor.

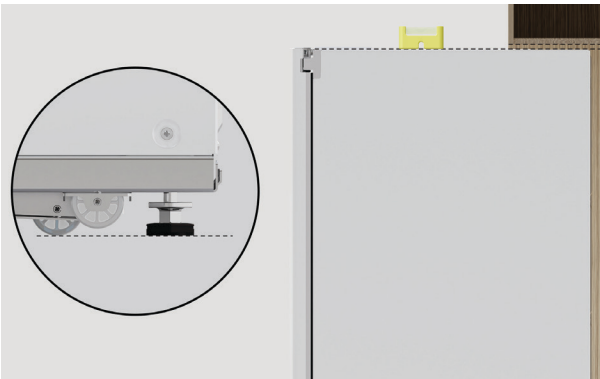

3. Prior to installing in alcove, adjust rear feet to the desired height

Ensure all clearances are maintained.

LEVEL CABINET



4. Tighten the locking nuts up to the base of the cabinet to lock feet in position.

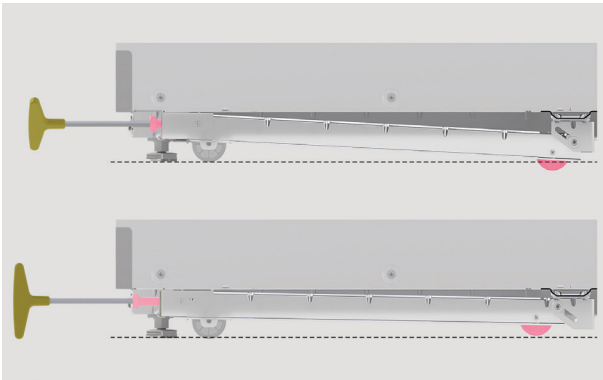

5. Lower the rear wheel to achieve clearance between rear feet and floor.

When adjusting the wheel, ensure front of the door doesn't damage the floor.

CONNECT CABLES



fisherpaykel.com/cn/zh_CN/specify

1. Refer to the Planning Guide for full service information.

Supply: 220 - 240V, 50Hz

Service: 10A

Outlet: 3-prong grounding-type



2. The supplied communication cable is for multi-product installations only. Set aside if product is being installed individually.



3. Route the power cable through service hole.

Ensure power will remain accessible following install to allow access for any future product maintenance.

CONNECT CABLES



4. Connect the power cable and check cabinet is powered on.

INSTALL CABINET



1. Push cabinet into cavity taking care not to damage cords.

Rotate the rear wheel adjustment screw anti-clockwise to place the full cabinet weight onto feet.

Ensure rear corners are level and set to the desired height.

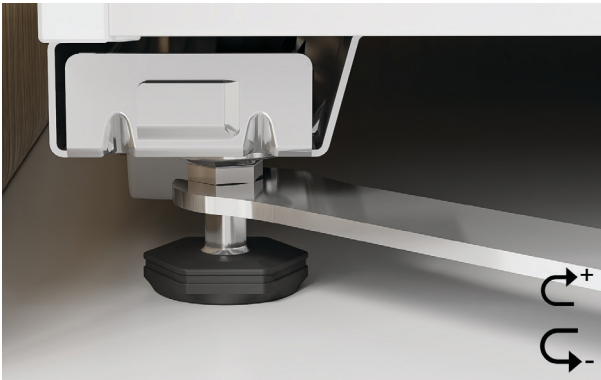

2. With cabinet in the final position, unscrew front levelling feet using the provided spanner. Re-check clearances and alignment before tightening the locking nuts up to the base of the cabinet to lock the feet into position.

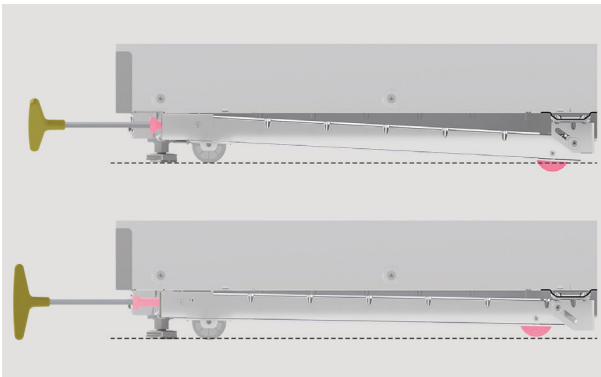

3. Ensure cabinet is resting on all four feet and all wheels have been raised.

INSTALL CABINET



4. Check final alignment and ensure required clearances are maintained.

Adjust as required.

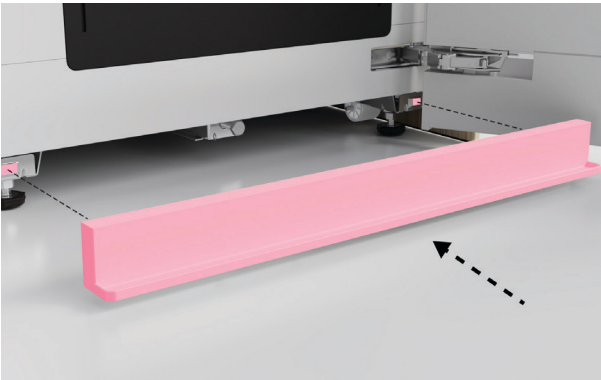

5. Clip drip tray into position.

FISHERPAYKEL.COM

© Fisher & Paykel Appliances 2024. All rights reserved.

The models shown in this guide may not be available in all markets
and are subject to change at any time.

The product specifications in this guide apply to the specific products and
models described at the date of issue. Under our policy of continuous product
improvement, these specifications may change at any time.

For current details about model and specification availability in your country,
please go to our website or contact your local Fisher & Paykel dealer.

431975A 01.24