

# Oven, 30", 4.1 cu ft, 17 Function, Self-cleaning

Series 9 | Professional

Stainless Steel



With professional styling, advanced cook functions and touchscreen, this large capacity oven is a highlight of our collection.

- Guided cooking using your touchscreen makes it simple to cook by food, function or recipe.
- 4.1 cu ft total capacity, with 17 oven functions including Aero™ Pastry and Roast, Air Fry and Dehydrate
- Non-tip, full extension sliding shelves for safe removal of hot dishes
- Accessories include food probe, smokeless grill tray, and more

## DIMENSIONS

Height	27 1/16"
Width	29 29/32"
Depth	23 29/32"

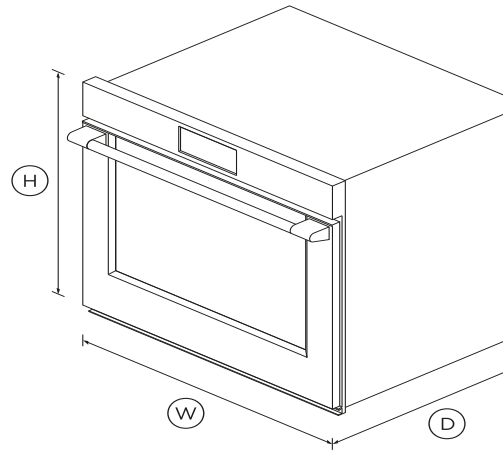

## FEATURES & BENEFITS

### Cook with confidence

Our touchscreen interface provides an intuitive guided cooking experience that helps deliver perfect results, whether you've been cooking all your life or just starting out. Cook with a favorite method, a hero ingredient, or a go-to cooking function or recipe.

### Generous capacity

With its 4.1 cu ft total capacity, you can create several perfectly

cooked dishes at once using multiple shelves.

### Multi-function flexibility

The cooking functions have each been tailored, tested, tweaked and perfected to ensure that no matter what you're cooking, you've got the right heat to match. Purchase our Wireless Temperature Sensor accessory and precisely monitor cooking in real time (accessory sold separately).

### Exceptional performance

AeroTech circulates heat evenly for a consistent temperature throughout the cavity, helping you ensure perfect results even when cooking on multiple shelves.

### Self-cleaning

Our self-clean technology breaks down food residue at a very high temperature, leaving a light ash that's easily removed with a damp cloth. The enamel coated side racks don't need to be removed when using this function.

### Design freedom

Designed to fit seamlessly into your kitchen, this built-in oven features premium materials and elegant styling to support a cohesive, considered kitchen design.

## SPECIFICATIONS

### Accessories

Broil rack	1 set
Full extension sliding shelves	3 sets
Roasting pan	1
Smokeless broil tray	1
Wired temperature sensor	1

### Capacity

Shelf positions	8
Total capacity	4.1cu ft

Usable capacity **3.6cu ft**

**Cleaning**

- Acid resistant graphite enamel •
- Removable oven door •
- Removable shelf runners •

**Consumption**

Energy usage **402kWh/year**  
 In-use energy carbon **49.6kgCO2e/year**

**Controls**

- Adjustable audio and display •
- Automatic cooking/minute •
- Automatic pre-set •
- Celsius/Fahrenheit •
- Electronic clock •
- Electronic oven control •
- Food probe •
- Guided cooking by food type •
- Intuitive touchscreen display •
- Multi-language display **UK English, US English,** •
- Sabbath mode with Star K •
- Wi-Fi connectivity •

**Functions**

- Aero Bake •
- Aero Broil •
- Air fry •
- Bake •

- Broil •
- Classic bake •
- Dehydrate •
- Maxi Broil •
- Number of functions **17**
- Pastry Bake •
- Pizza bake •
- Rapid proof •
- Roast •
- Self-clean •
- Slow cook •
- True Aero •
- Vent bake •
- Warm •

**Performance**

- AeroTech™ technology •
- Automatic rapid pre-heat •
- Broil power **4400W**
- Broil width **20"**
- Number of passes on Maxi **12**
- Number of passes on broil **10**

**Power requirements**

Amperage **16.6 - 19.4A**  
 Supply voltage **208 / 240V**

**Product dimensions**

Depth **23 29/32"**  
 Height **27 1/16"**

Width **29 29/32"**

**Safety**

- ADA compliant •
- Balanced oven door •
- Catalytic venting system •
- Control panel key lock •
- CoolTouch door •
- Non-tip shelves •

SKU **81921**

The product dimensions and specifications in this page apply to the specific product and model. Under our policy of continuous improvement, these dimensions and specifications may change at any time. You should therefore check with Fisher & Paykel's Customer Care Centre to ensure this page correctly describes the model currently available. ? Fisher & Paykel Appliances Ltd 2020

---

Other product downloads available at [fisherpaykel.com](https://fisherpaykel.com)

- [↓](#) User Guide
- [↓](#) Guide d'utilisation FR
- [↓](#) Energy Label
- [↓](#) Service & Warranty
- [↓](#) User Guide Built-In Oven EN
- [↓](#) Guide d'utilisation FR
- [↓](#) Installation Guide
- [↓](#) Guide d'installation FR
- [↓](#) Data Sheet Oven
- [↓](#) Planning Guide - Professional 30" Built-in Ovens and Companions
- [↓](#) Planning Guide Professional Style Dial/Handle Accessories



**A PEACE OF MIND SALE**

24 Hours 7 Days a Week Customer Support

T 1.888.936.7872 **W**[www.fisherpaykel.com](https://www.fisherpaykel.com)