

30" Series 7 Professional 5 Burner Gas Range, LPG

Width 29 7/8 "
Depth 29 1/8 "

A sealed cooktop surface coupled with a commercial-style stainless steel finish means your cooktop simply needs a quick wipe to keep it looking good as new.

Professional

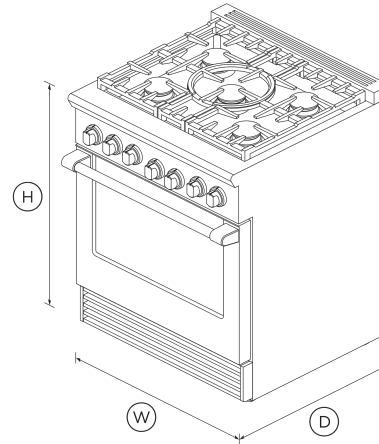

Instant Visibility

Control dials have halo-illumination glowing white – heating up; orange – temperature reached; red – self-cleaning mode. The oven is illuminated by two powerful incandescent lights.

Cooking Flexibility

The cooktop is designed for easy access to any burner with grates you can smoothly slide pots across. The oven is large enough to hold full size baking sheets.

Design Quality

This range has been carefully crafted in every detail from performance to durability using quality materials.

SPECIFICATIONS

FEATURES & BENEFITS

Cooktop Power

Sealed Dual Flow Burners™ deliver cooktop power up to 23,500 BTU (NG models) for seriously fast boiling right down to a precise 140°F full surface simmer with the gentlest of flames.

Total Control

Precise control across high and low settings is delivered through the halo-illuminated cooktop dials. The ovens have true convection and electronic oven control for precise and consistent temperatures.

Easy To Clean

Accessories (sold separately)

Square handle option	AH-R30
Wok grate included	Yes

Burner ratings

Maximum burner power	19000 BTU
Power back left	11500BTU
Power back right	11500BTU
Power centre	19000BTU
Power front left	15000BTU
Power front right	15000BTU
Total cooktop power	72000 BTU

Professional style and performance, with powerful burners delivering high heat or the most gentle simmer.

- Top burner heat of 19,000 BTU, for seriously fast boiling
- Gas oven with 4.6 cu ft total capacity
- Non-tip full-extension shelves for safe removal of hot dishes

DIMENSIONS

Height 35 3/4 - 36 3/4 "

Capacity	
Shelf positions (main oven)	5

Rated current	15 A
Supply frequency	60 Hz

Controls	
Electric circuit	3
Metal illuminated dials	•

Product dimensions	
Depth	29 1/8 "
Depth (excluding handles)	2918 mm
Height	35 3/4 - 36 3/4 "
Width	29 7/8 "

Gas Requirements	
Fitting and pipe	½ NPT, min. ⅝" flex line
Supply Pressure (LPG)	11" to 14" W.C

Rangetop features	
Sealed range top	•
Vent trim included	•

Oven features	
Auto re-ignition system	•
Broil pan	•
Electronic oven control	•
Full extension telescopic sliding shelves	•
Infrared Broiler	•

Safety	
ADA compliant	•
Full extension telescopic sliding shelves	•

Oven functions	
Bake	•
Broil	•
Convection bake	•
Number of functions	3

SKU 71359

The product dimensions and specifications in this page apply to the specific product and model. Under our policy of continuous improvement, these dimensions and specifications may change at any time. You should therefore check with Fisher & Paykel's Customer Care Centre to ensure this page correctly describes the model currently available. © Fisher & Paykel Appliances Ltd 2020

Other product downloads available at fisherpaykel.com

- [↓ DWG](#)
- [↓ DXF](#)
- [↓ Archicad](#)
- [↓ Data Sheet \(English\)](#)
- [↓ Installation Guide \(English, Canadian French\)](#)
- [↓ Planning Guide \(English\)](#)
- [↓ Revit](#)
- [↓ Rhino](#)
- [↓ Right To Repair Declaration \(English, Canadian French\)](#)
- [↓ SketchUp](#)
- [↓ User Guide \(English\)](#)
- [↓ User Guide \(Canadian French\)](#)

Where applicable:

All appliances use energy, and energy usage typically generates carbon emissions. **Fisher & Paykel Appliances' In-use Energy Carbon Emissions Estimate** indicates carbon emissions from a product's in-use energy. This is calculated either annually or per cycle, using the product's market-specific energy label energy consumption data multiplied by the carbon emissions factor for energy in your country or region.

Our In-use Energy Carbon Emissions Estimate is designed to assist customers in making informed purchasing decisions when comparing different Fisher & Paykel products. For example, a heat pump dryer typically has a lower In-use Energy Carbon Emissions Estimate than a vented dryer.



A PEACE OF MIND SALE
24 Hours 7 Days a Week Customer Support
 T 1.888.936.7872 W www.fisherpaykel.com