

FISHER & PAYKEL

PROFESSIONAL RANGE

RGV2 & RDV2
models

USER GUIDE

US CA

⚠ WARNING!

If the information in this manual is not followed exactly, a fire or explosion may result causing property damage, personal injury or death.

Do not store or use gasoline or other flammable vapors and liquids in the vicinity of this or any other appliance.

NEVER use this appliance as a space heater to heat or warm the room. Doing so may result in carbon monoxide poisoning and overheating of the appliance.

WHAT TO DO IF YOU SMELL GAS

- Do not try to light any appliance.
- Do not touch any electrical switch.
- Do not use any phone in your building.
- Immediately call your gas supplier from a neighbor's phone.
Follow the gas supplier's instructions.
- If you cannot reach your gas supplier, call the fire department.

Installation and service must be performed by a qualified installer, service agency or the gas supplier.

CONTENTS

Safety and warnings	2
Introduction	6
First use	
Conditioning the oven	10
Seasoning the griddle	10
Oven use	
Positioning the shelves	11
Using your oven for baking and roasting	14
Using your oven for broiling	15
Using your oven for proofing dough	16
Oven cooking guidelines	18
Oven modes	21
Baking charts	24
Cooktop use	
Using the cooktop burners	30
Guidelines for using the cooktop burners	31
Using the grill	32
Using the griddle	33
Care and cleaning	
Manual cleaning chart	34
Removing and replacing the oven door	40
Removing and replacing the side racks	42
Replacing the burner parts	43
Replacing the oven light bulb	44
Using the CLEAN cycle	45
Troubleshooting	48
Alerts	53
Warranty and service	54

IMPORTANT! **SAVE THESE INSTRUCTIONS**

The models shown in this user guide may not be available in all markets and are subject to change at any time. For current details about model and specification availability in your country, visit our website www.fisherpaykel.com or contact your Fisher & Paykel dealer.

SAFETY AND WARNINGS

To reduce the risk of fire, electrical shock, injury to persons, or damage when using the appliance, follow the important safety instructions listed below:

WARNING!



Electrical Shock Hazard

Before removing a faulty oven light bulb, make sure you turn the power to the range off at the main fuse or circuit breaker panel. If you don't know how to do this, contact an electrician.

Do not remove the kickstrip grate. Due to access to live electrical parts behind it, the kickstrip grate should only be removed by a qualified technician.

This appliance is equipped with a three-prong or four-prong grounding plug for your protection against shock hazard and should be plugged directly into a properly grounded power outlet. Do not under any circumstances cut or remove the grounding prong from this plug. Failure to follow this advice may result in death or electrical shock.

WARNING!



Tipping Hazard

A child or adult can tip this range and be killed. It must be secured by a properly installed anti-tip bracket. See installation instructions for details. Ensure the anti-tip device is re-engaged when the range is moved.

Do not use the appliance until it has been secured.

Failure to do so can result in or death or serious burns to children or adults.

WARNING!



Fire Hazard

Never use your appliance for warming or heating the room. Persons could be injured or a fire could start.

Keep the area around the appliance free from combustible materials (eg wall coverings, curtains, drapes), gasoline and other flammable vapors and liquids.

Do not let cooking grease or other flammable materials accumulate in, or near the appliance.

Do not hang any articles (eg dish towels) off the oven handle. Some fabrics may ignite or melt from the heat.

Never leave the cooktop burners unattended when in use -

Boilover causes smoking and greasy spillovers that may ignite.

Be sure all the controls are turned off and the appliance is cool before using any type of aerosol cleaner on or around the appliance. Chemicals in such cleaners could, in the presence of heat, ignite or cause metal parts to corrode.

Failure to follow this advice may result in death or serious injury.

SAFETY AND WARNINGS

WARNING!



Explosion Hazard

If you smell gas, do not use the appliance. Open a window or door to let the gas escape, then follow the instructions on the inside front cover of this manual.

Do not use water on grease fires. A violent steam explosion may result. Turn all burners off, then smother fire or flame or use dry chemical or foam-type extinguisher.

Do not heat unopened food containers such as cans - Build-up of pressure may cause container to burst and result in injury. Failure to follow this advice may result in injury or death.

WARNING!



Poisoning Hazard

Never cover any slots, holes or passages in the oven bottom or cover an entire rack or the oven floor with materials such as aluminum foil. Doing so blocks airflow through the oven and may cause carbon monoxide poisoning. Aluminum foil linings may also trap heat, causing a fire hazard. Clean the appliance with caution. If a wet sponge or cloth is used to wipe spills on a hot cooking area, be careful to avoid steam burn. Some cleaners can produce noxious fumes if applied to a hot surface. Follow the directions of the cleaner manufacturer.

Never use this appliance as a space heater to heat or warm the room. Doing so may result in carbon monoxide poisoning and overheating of the appliance.

Failure to follow this advice may result in poisoning or death.

WARNING!



Hot Surface Hazard

Accessible parts may become hot during use.

Do not touch burners, areas near burners, the grill, griddle, grease drippans, heating elements or interior surfaces of oven - These may be hot enough to cause burns even though they are dark in color. During and after use, do not touch, or let clothing or other flammable materials contact these parts and surfaces until they have had sufficient time to cool. Other parts and surfaces of the appliance may become hot enough to cause burns - among these areas are the grates, back trim and oven vents at the back of the cooktop, front edge, surfaces adjacent to the cooktop, and the oven door.

Use only dry potholders - Moist or damp potholders on hot surfaces may result in burns from steam. Do not let potholder touch hot heating elements. Do not use a towel or other bulky cloth.

Let hot grease cool before attempting to handle it.

Ovens with a CLEAN cycle: During self-cleaning, the oven reaches higher temperatures than it does for cooking. Under such conditions, the surfaces may get hotter than usual. Children should be kept away.

Failure to follow this advice may result in serious injury.

IMPORTANT SAFETY INSTRUCTIONS!

- **Read all the instructions before using the appliance. Use the appliance only for its intended purpose as described in these instructions.**
- **Proper installation – Be sure your appliance is properly installed and grounded by a qualified technician. A risk of tip-over exists when the appliance is not installed in accordance with the installation instructions.**
- **Do not operate the appliance if it is damaged or not working properly. If you received a damaged product, contact your dealer or installer immediately.**
- **Be sure to have the installer show you where and how to turn off the power supply to the range (ie location of the main fuse or circuit breaker panel) and where and how to turn off the gas supply to the range in an emergency.**
- **Do not leave children alone – Children should not be left alone or unattended in the area where the appliance is in use. They should never be allowed to play with the appliance or to sit or stand on any part of the appliance.**
- **Caution – for safety reasons, do not store items of interest to children in cabinets above a range or at the back of the range – children climbing on the range to reach items could be seriously injured.**
- **Wear proper apparel – Loose-fitting or hanging garments should never be worn while using the appliance.**
- **User servicing – Do not repair or replace any part of the appliance unless specifically recommended in the manual. All other servicing should be referred to a qualified technician. Technicians must disconnect the appliance from the power supply before any servicing.**
- **Storage in or on appliance – Flammable materials should not be stored in an oven or near the cooktop.**
- **Use care when opening the oven door – Let hot air or steam escape before removing or replacing food.**
- **Keep oven vent ducts unobstructed.**
- **Keep rugs and mats well clear of the base of the range.**
- **Placement of oven shelves – Always position shelves in the desired location while the oven is cool (before preheating). If a shelf must be removed while the oven is hot, do not let oven mitts or potholder contact the base of the oven or hot heating elements in the oven.**
- **Do not clean the oven gasket or use any oven-cleaning products on it. It is essential for a good seal, which ensures that the oven operates efficiently. Care should be taken not to rub, damage or move it.**
- **Do not use oven cleaners, harsh/abrasive cleaning agents, waxes, or polishes in a self-cleaning oven. No commercial oven cleaner, oven liner, or protective coating of any kind should be used in or around any part of a self-cleaning oven.**
- **Do not use harsh/abrasive cleaners, scourers or sharp metal scrapers to clean the oven door glass since they scratch the surface, which may result in the glass shattering.**
- **Do not sit or stand on the oven door or place any heavy objects on it – doing so may result in personal injury.**
- **Be careful when reaching for items stored in cabinets above the appliance.**

IMPORTANT SAFETY INSTRUCTIONS!

- **Safe food handling:** leave food in the oven for as short a time as possible before and after cooking. This is to avoid contamination by organisms which may cause food poisoning. Take particular care during warmer weather.
- Clean only the parts listed in this manual.
- Do not use a steam cleaner to clean any part of the appliance.
- Do not obstruct the flow of combustion and ventilation air to the appliance.
- Before self-cleaning the oven - Remove oven shelves, side racks, broiler pan and all other cookware/utensils, and wipe up large food spills or grease deposits.
- Before self-cleaning the oven -make sure you move any pet birds to another, closed and well-ventilated room. Some pet birds are extremely sensitive to the fumes given off during a self-cleaning cycle, and may die if left in the same room as the range during such a cycle.
- Do not use any cookware on the grill or griddle.
- Top cover (lid) must be removed when the grill or griddle is in operation.
- When using the grill or griddle, make sure the grease drip-pan is in place - absence of this during use may subject wiring or components underneath to damage.
- The oven(s), grill, and griddle of your range cannot be used in the event of a power failure. Do not attempt to operate these during power failure.
- Do not use aluminum foil to line any part of the oven or cooktop. This will cause heat to be trapped underneath it. This trapped heat can upset the cooking performance and damage the finish of the oven or cooktop parts.
- Do not place any dishes, trays, water or ice directly on the oven floor during cooking, as doing so will irreversibly damage the porcelain enamel finish.
- For safety reasons, the cooktop burner flame size should be adjusted so it does not extend beyond the edge of the cookware.
- Use cookware of the appropriate size and construction for the type of cooking. This appliance is equipped with burners of different sizes. Cookware must be matched to the size of the burner. Select utensils with flat bottoms large enough to cover the burner flames. The use of undersize utensils will expose a portion of the burner flames to direct contact and may result in ignition of clothing. Proper relationships of utensil to burner will also improve efficiency.
- Protective liners - Do not use aluminum foil to line grease drip-pans or oven bottoms.
- Glazed cooking utensils - only certain types of glass, glass/ceramic, ceramic, earthenware, or other glazed utensils are suitable for cooktop service without breaking due to the sudden change in temperature.
- Utensil handles should be turned inward and not extend over adjacent cooktop burners - To reduce the risk of burns, ignition of flammable materials, and spillage due to unintentional contact with the utensil, the handle of a utensil should be positioned so that it is turned inward, and does not extend over adjacent cooktop burners.
- The Governor of California is required to publish a list of substances known to the State of California to cause cancer or reproductive harm and requires businesses to warn customers of potential exposures to such substances.
- **WARNING!:** This product emits exhaust that contains chemicals known to the State of California to cause cancer, birth defects, and other reproductive harm. To reduce the risk from such chemicals, make sure this appliance is installed, operated, and maintained according to the manufacturer's instructions.

INTRODUCTION

48" MODELS

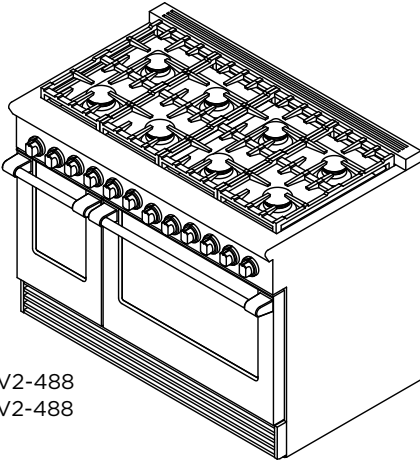

RGV2-488
RDV2-488

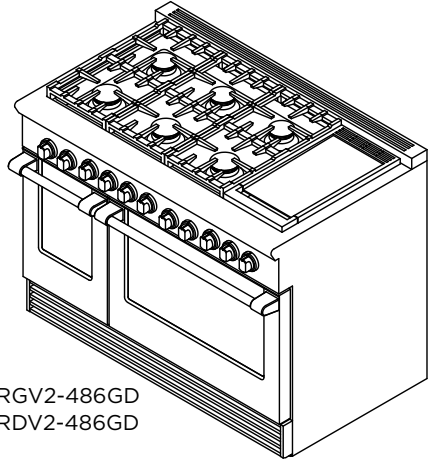

RGV2-486GD
RDV2-486GD

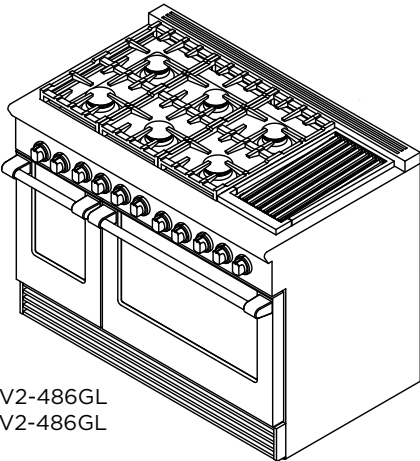

RGV2-486GL
RDV2-486GL

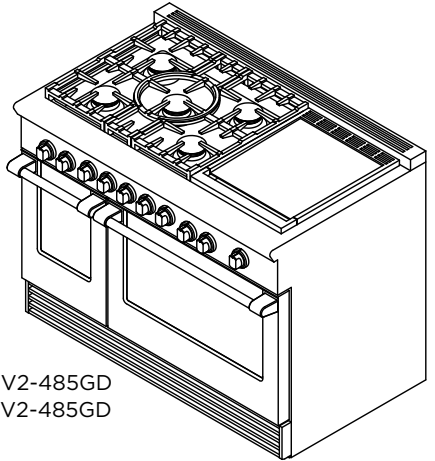

RGV2-485GD
RDV2-485GD

INTRODUCTION

36" MODELS

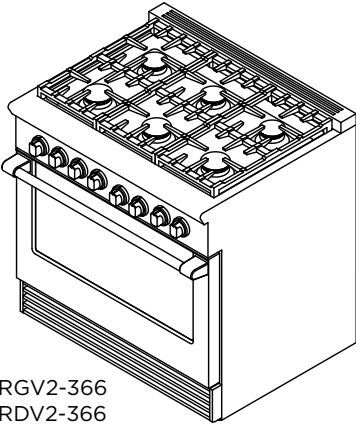

RGV2-366
RDV2-366

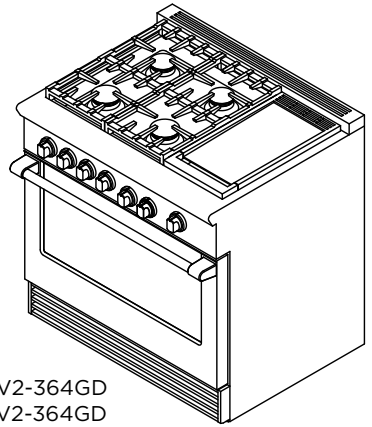

RGV2-364GD
RDV2-364GD

30" MODELS

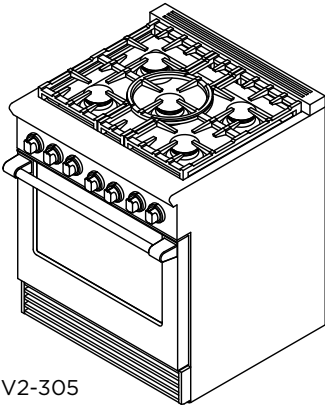

RGV2-305
RDV2-305

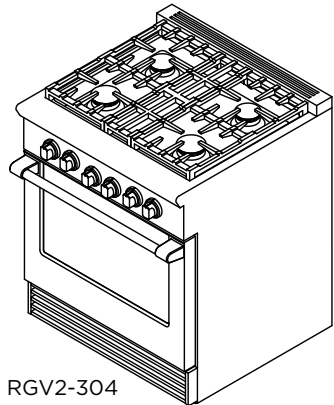

RGV2-304
RDV2-304

INTRODUCTION

Before you start

- ① Make sure that the anti-tip bracket at the right rear of the range has been properly installed.
- ② Open the main oven door and find the model and serial numbers on the label in the bottom right-hand corner of the oven frame (see the drawing opposite). Note these numbers down for future reference in the space provided in section 'Warranty and service'.
- ③ Read this guide, taking special note of the 'Safety and warnings' section.
- ④ Remove all the packaging from the oven(s) and cooktop. Recycle items that you can. If any adhesive residue is left on surfaces, remove this using dishwashing liquid on a soft cloth.
Do not use any harsh or abrasive cleaners.
- ⑤ Make sure you follow the instructions under 'First use' before using your range for cooking.

IMPORTANT!

Do not block the vents of the oven, griddle and oven door with cookware, utensils or towels. During cleaning, take care not to let any liquids run down these vents.

INTRODUCTION

Model may vary

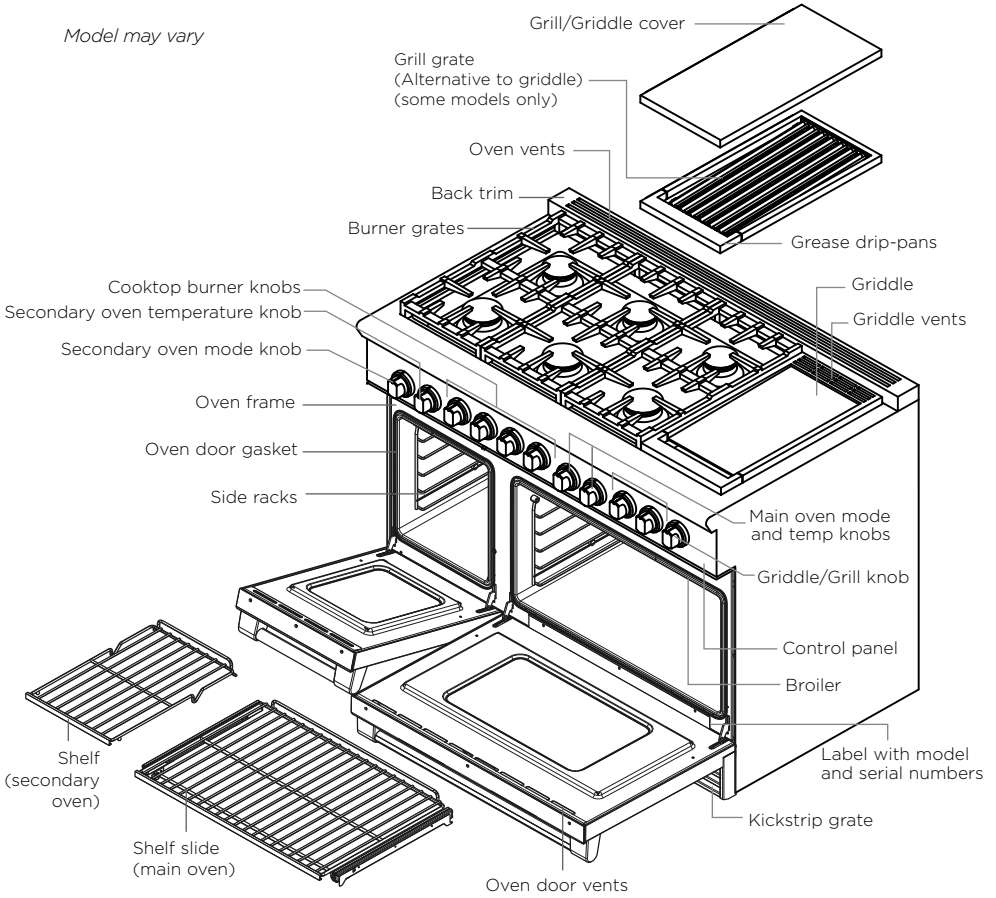

Accessories

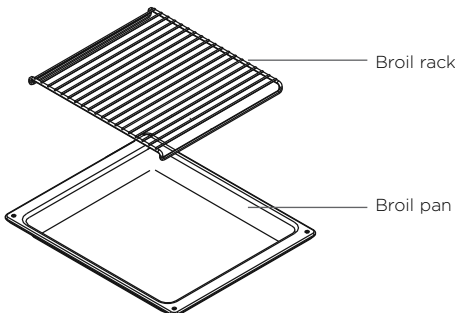

FIRST USE

Conditioning the oven

Conditioning will burn off any manufacturing residues and ensure that you get the best results right from the start.

- ① Insert all the shelves. See 'Positioning the shelves' for instructions.
- ② Turn on the ventilation hood above your range on high.
- ③ Heat the empty oven at 450°F / 232°C for:
 - 30 minutes using BAKE
 - 30 minutes using BROIL (some ovens only).See sections 'Using your oven for baking and roasting' and 'Using your oven for broiling' for instructions.
- There will be a distinctive smell while you are conditioning the oven. This is normal, but make sure the kitchen is well ventilated during the conditioning.
- ④ Once cooled, wipe out the oven with a damp cloth and mild detergent, and dry thoroughly.

IMPORTANT!

If your range has a secondary oven, make sure you condition this also, following the steps above.

Seasoning the griddle

- ① Clean the griddle thoroughly with hot, soapy water to remove any protective coating.
- ② Rinse with a mixture of 1 cup water and ¼ cup white vinegar, then dry thoroughly.
- ③ Pour 1 tsp vegetable (but not corn) oil into the center of the griddle, then rub it over its entire surface, using a soft, heavy cloth.
- ④ Turn the griddle knob counterclockwise to 350°F / 177°C.
- ⑤ When the oil begins to smoke, turn the knob clockwise back to OFF and allow the griddle to cool.
- ⑥ Repeat steps 3 to 5.
- ⑦ Wipe the entire surface of the griddle using a soft, heavy cloth.
- ⑧ Apply a very thin layer of vegetable (but not corn) oil.
- ⑨ Check the grease drip-pan and clean if necessary. Discard any liquid or soiling that may have collected in the grease drip-pan during the conditioning.
- The griddle is now ready to use.
- For best results, re-season the griddle after long periods of non-use.
- Note: the griddle will darken with use. This is normal.

OVEN USE

Positioning the shelves

- Shelf positions are numbered from the bottom.
- Position the shelves you will need before turning the oven on.
- For advice on which shelf position to use, see sections 'Oven modes', 'Oven cooking guidelines', and 'Cooking charts'.

IMPORTANT!

Always position the oven shelves before turning the oven on. Remove any unused shelves and baking utensils from the oven.

SECONDARY OVEN (48" models only)

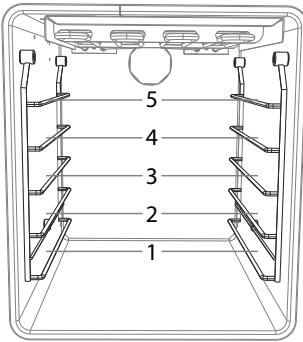

MAIN OVEN

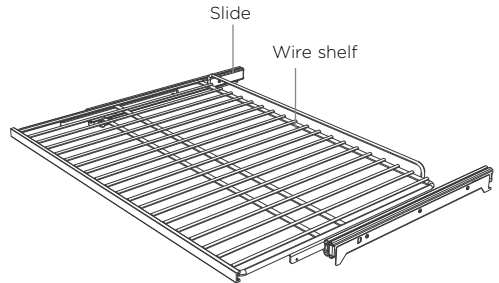
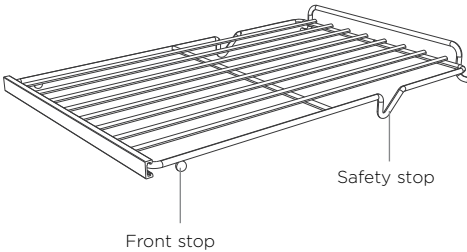
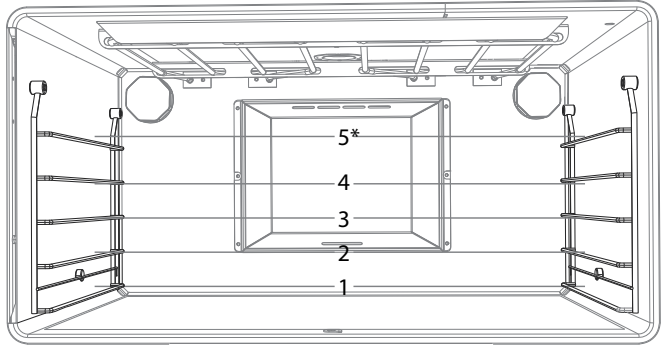

Secondary oven shelves

- These shelves have safety stops to keep them from sliding out of the oven when pulled forward.
- The front stops prevent the shelves from hitting against the back of the oven.

Main oven shelves

- The wire shelves and slides are built together as one unit.
- When positioned correctly, the slides will prevent the wire shelves from tilting when pulled forward.
- Beware: these shelves are heavy.

IMPORTANT!

If you have an RDV2 model, never leave these shelves in the oven during a CLEAN cycle. If you do, they will no longer slide smoothly.

OVEN USE

To insert the shelves - MAIN OVEN

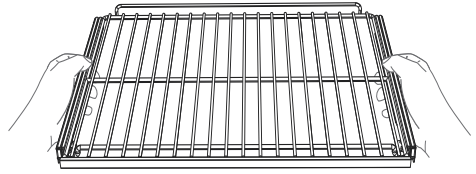
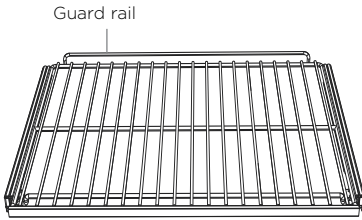

- ① Make sure the guard rail is at the back, facing up and the slides are not extended.
- ② Hold the shelf firmly with both hands, making sure you grip the wire shelf too to stop it sliding forward.

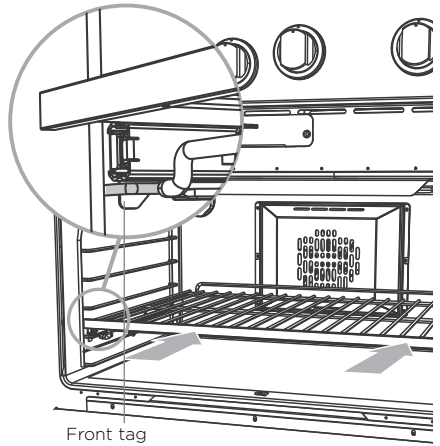
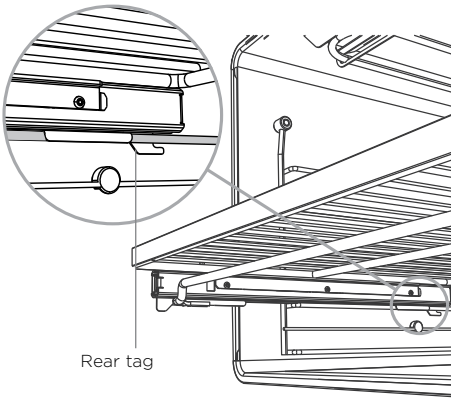

- ③ Hook the rear tags over the wires of the desired shelf position on both side racks.
- ④ Push the shelf all the way into the oven, ensuring the front and rear tags either side are securely locked behind the side rack wires.

To remove the shelves

- ① **Wait for the oven to cool down completely.**
- ② Hold the shelf firmly with both hands, making sure you grip the wire shelf too to stop it sliding forward.
- ③ Pull the shelf forward about $\frac{3}{4}$ of the way.
- ④ Lift the rear of the shelf slightly so that the tags clear the side rack wires, then remove.

OVEN USE

To insert the shelves - SECONDARY OVEN (48" models only)

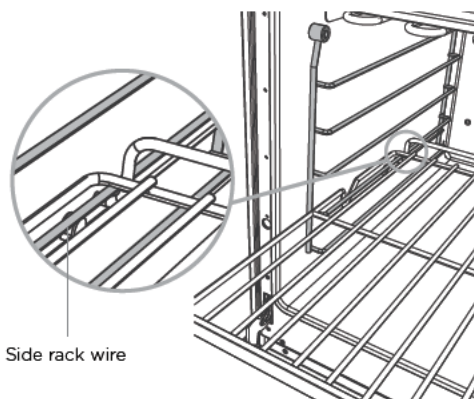

- ① Make sure the guard rail is at the back, facing up.
- ② Position the shelf: it should rest on the side rack wires, as shown.

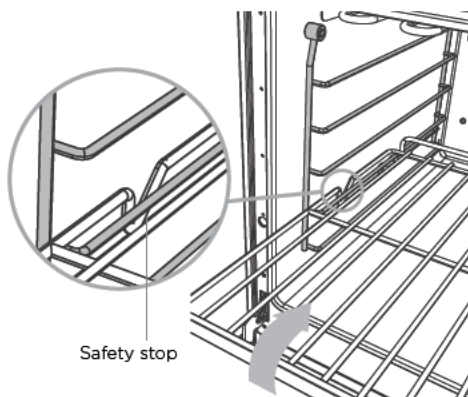

- ③ Tilt the front up slightly to help the safety stops clear the side rack wires.
- ④ Lower the shelf back onto the side rack wires and slide all the way into the oven.

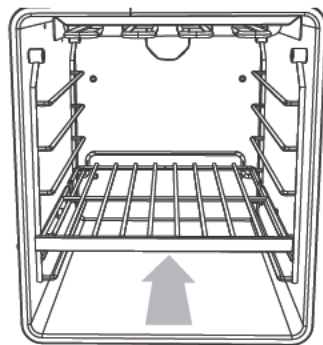

To remove the shelves

- ① Wait for the oven to cool down completely.
- ② Pull the shelf forward about $\frac{3}{4}$ of the way.
- ③ Tilt the front up slightly to help the safety stops clear the side rack wires.
- ④ Remove the shelf.

Using your oven for baking and roasting

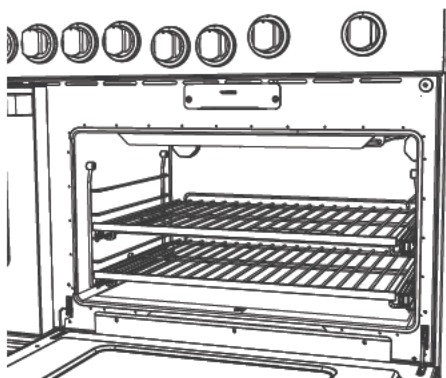

- ① Check that you have the shelf/shelves you will need in place.
 - If not, see section 'Positioning the shelves' for instructions.

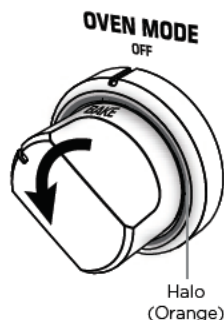

- ② Turn the OVEN MODE knob counterclockwise to BAKE, BAKE CONVECTION or TRUE CONVECTION (some models only).
 - The halo will glow orange.

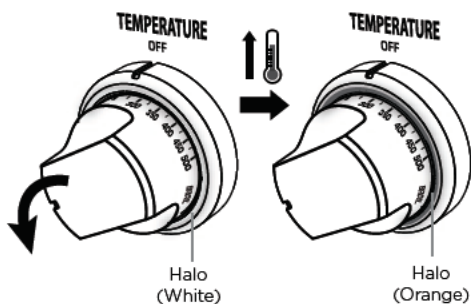

- ③ Turn the TEMPERATURE knob counterclockwise to the desired temperature.
 - While the oven is heating up, the halo will glow white.
 - When the oven has reached the set temperature (approx. 10-20 minutes), the halo will turn orange.
 - Note: the halo may alternate between white and orange during cooking as the oven maintains the set temperature.

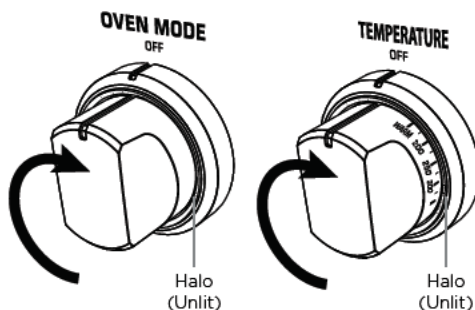

- ④ When you have finished using the oven, turn both the oven mode and temperature knobs clockwise to OFF.
 - The halos will go out.
 - You may continue to hear the noise of the cooling fan: it is normal for the fan to stay on.

OVEN USE

Using your oven for broiling

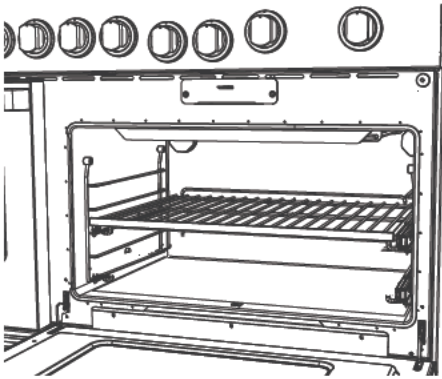

- ① Check that you have the shelf you will need in place.
 - If not, see section 'Positioning the shelves' for instructions.

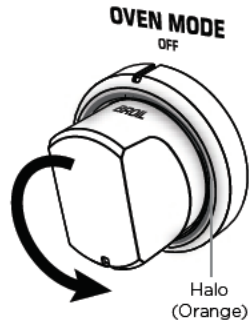

- ② Turn the OVEN MODE knob counterclockwise to BROIL or BROIL CONVECTION (some models only).
 - Make sure you turn the knob exactly to the setting, never past it.
 - The halo will glow orange.



- ③ Turn the TEMPERATURE knob counterclockwise to BROIL or alternatively, a desired lower temperature.
 - The halo will glow orange.
 - For best results when you want quick browning or searing, preheat the broiler for about 5-8 minutes before placing food in the oven.

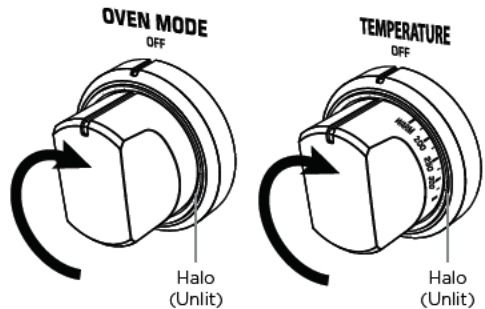

- ④ When you have finished using the oven, turn both the oven mode and temperature knobs clockwise to OFF.
 - The halos will go out.
 - You may continue to hear the noise of the cooling fan: it is normal for the fan to stay on.

OVEN USE

Using your oven for proofing dough

If your model has a secondary oven, we recommend using it for proofing dough, as the smaller volume ensures a more even temperature.

RDV2/RGV2-48" models only

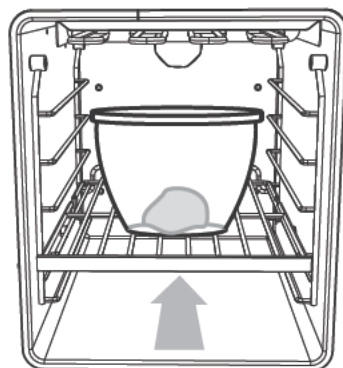
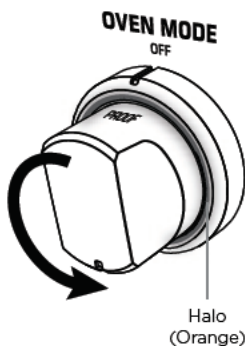

- ① Turn the OVEN MODE knob of the secondary oven counterclockwise to PROOF.
 - The oven will heat to an ideal proofing temperature (100°F) in about 5 minutes.
- ② AFTER 5 MINUTES, place the dough in the oven in a covered and lightly-oiled, heatproof bowl.

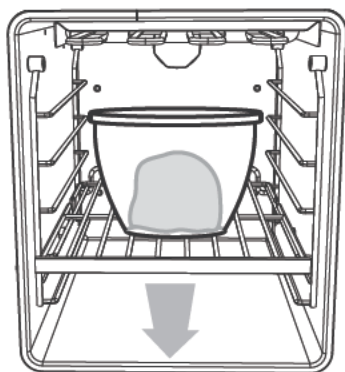

- ③ When risen to the required size, remove the dough from the oven.
- ④ Turn the oven mode knob clockwise back to OFF.

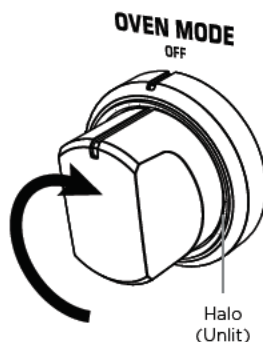

OVEN USE

Using your oven for proofing dough

All other models

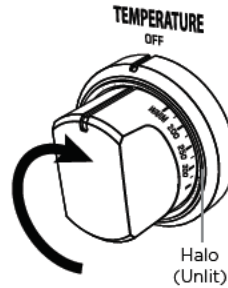
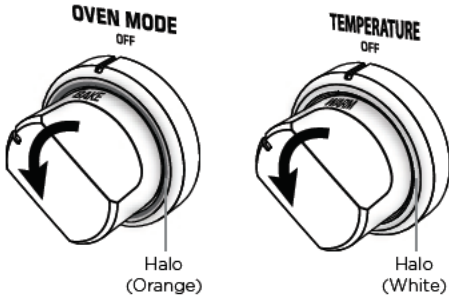

- ① Turn the OVEN MODE knob counterclockwise to BAKE and the TEMPERATURE knob counterclockwise to WARM.
 - The oven will heat to an ideal proofing temperature (100°F) in about 5 minutes.
- ② AFTER 5 MINUTES, turn the temperature knob clockwise back to OFF.

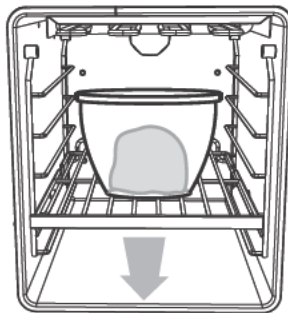
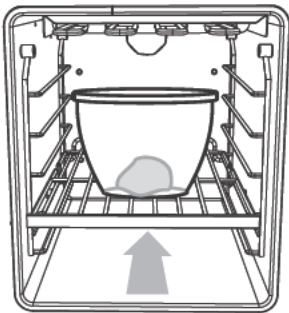

- ③ Place the dough in the oven in a covered and lightly-oiled, heatproof bowl.
- ④ When risen to the required size, remove the dough from the oven and turn the oven mode knob clockwise back to OFF.

Oven cooking guidelines

IMPORTANT!

- **Use all the oven modes with the oven door closed.**
- **Never use aluminum foil to cover the oven shelves or to line the floor of the oven. The trapped heat can irreversibly damage the enamel and may even cause fire.**
- **Do not place water, ice, or any dish or tray directly on the oven floor, as this will irreversibly damage the enamel.**
- **Do not cover the broil pan with aluminum foil. This will catch the grease and could cause fire.**
- **Do not use plastic wrap or wax paper in the oven.**
- **For food safety reasons, do not leave food in the oven for longer than two hours before and after cooking or defrosting. This is to avoid contamination by organisms which may cause food poisoning. Take particular care during warmer weather.**
- **After a power cut you need to turn both oven dials to OFF before you can begin cooking again.**

BAKING

- For best results when baking, always preheat your oven. The broil element may turn on for a short time while the oven is heating up. Depending on the temperature and the size of the oven, preheating will take around 10-20 minutes. The temperature dial will turn from white to orange when the preset temperature is reached.
- Your cookware will influence baking times. Dark pans absorb the heat more quickly than reflective pans; glass cookware may require a lower temperature.
- Avoid opening the oven door frequently during baking. Do not open the oven door until at least $\frac{3}{4}$ through the suggested baking time.

Shelf Position Guide

Place your baking on a shelf that will have the top of your pan near the center of the oven cavity.

- If you have a 48" range, the main oven is ideal for multi-shelf baking or baking larger quantities. For smaller quantities baked on a single shelf, use the secondary oven.
- Arrange pans and food items evenly on the shelves. Make sure pans do not touch each other or the sides of the oven. When baking a single item, always center the item on the oven shelf. If baking on multiple shelves, make sure you stagger items on the shelves so that one is never directly above another.
- When baking a single item, shelf position 2 is the most frequently used. See 'Cooking Charts' for more shelf position suggestions.

COOKING GUIDE

Oven cooking guidelines

ROASTING

- The broil rack and broil pan are ideal for broiling and roasting. Place meat on the broil rack (on top of the broil pan) to allow hot air to circulate around it. This gives more even browning and a result similar to a rotisserie.
- Boneless, rolled or stuffed roasts take longer than roasts containing bones.
- Use a meat thermometer to determine when meat is cooked.
- Poultry should be well cooked with the juices running clear and an internal temperature of 165°F / 74°C.
- Cook larger cuts of meat at a lower temperature for a longer time. The meat will cook more evenly.
- Always roast meat fat side up. That way basting may not be required.
- Always rest the meat for at least 10 minutes after roasting to allow the juices to settle. Remember the meat will continue to cook for a few minutes after removing it from the oven.

Shelf Position Guide

Place the meat on a shelf so that it is in the center of the oven or lower.

BROILING

- This is a healthier alternative to frying.
- Always broil with the oven door completely shut. If you open the oven door to check food, have it open for as short a time as possible to prevent the control panel overheating.
- If you use glass or ceramic pans, be sure they can withstand the high temperatures of broiling.
- To avoid piercing the meat and letting juices escape, use tongs or a spatula to turn the meat halfway through cooking.
- Brush meat with a little oil to help keep the meat moist during cooking. Alternatively marinate the meat before broiling (but be aware that some marinades may burn easily).
- Where possible broil cuts of meat of a similar thickness at the same time. This will ensure even cooking.
- Always keep a close watch on your food while broiling to avoid charring or burning.
- Use the grill rack and roast dish for perfect results.

Shelf Position Guide

- For thinner cuts of meat, toasting or browning foods, use a higher shelf position.
- Thicker cuts of meats should be broiled on lower shelves or at a lower broil setting to ensure even cooking.

COOKING GUIDE

Oven cooking guidelines

REHEATING

- Use BAKE or BAKE CONVECTION to reheat food.
- BAKE mode is particularly good for reheating pastry based items, as the base heat will help re-crisp the pastry case.
- Always reheat food to piping hot. This reduces the risk of contamination by harmful bacteria.
- Once hot, reduce the temperature to WARM to keep the food warm.
- **Never reheat food more than once.**

If you wish to finish cooking using the residual heat in the oven

Leave the oven on and reduce the heat to the lowest temperature. Leaving the oven on will decrease the risk of condensation forming (condensation may cause damage to the oven cavity and surrounding cabinetry).

DEFROSTING

- To thaw uncooked frozen food, set the oven mode to BAKE or BAKE CONVECTION and set the temperature to WARM. Once thawed, cook the food immediately and do not refreeze.
- To prevent liquid from thawing food dripping on the oven floor, be sure any uncooked food is tightly wrapped in foil and/or placed in a container.

PROOFING DOUGH

- Use a lightly-oiled heatproof glass bowl to proof your dough. This allows you to check how much it has risen without opening the oven or removing the cover over the bowl.
- To lock in or increase moisture during proofing, cover the bowl with a damp dish towel

DEHYDRATING FRUIT

- To obtain high quality dried fruit, select only unblemished, ripe fruit.
- Wash fruit thoroughly and pat dry. Peel if desired. Fruit that is not peeled will take longer to dry. Remove pits, stems or seeds if necessary. Place fruit on a baking tray on a shelf in the oven.
- We recommend using TRUE CONVECTION or BAKE CONVECTION set at a temperature between WARM and 200°F.

For more oven cooking tips, visit our website, www.fisherpaykel.com.

OVEN MODES

IMPORTANT!

- Use all the modes with the oven door closed.

BAKE

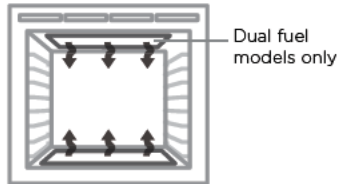

- Heat may come from either the upper and lower areas of the cavity. The fan is not used in this mode.
- Ideal for cakes and foods that require baking for a long time or at low temperatures.
- This mode is not suitable for multi-shelf cooking.

Ideal for moist foods that take a longer time to cook, such as rich fruit cake.

BAKE CONVECTION

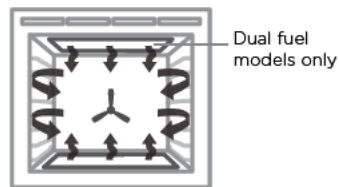

- The oven fan circulates hot air from either the upper and lower areas of the cavity and distributes it around the oven cavity.
- Food cooked on BAKE CONVECTION tends to brown more quickly than foods cooked on BAKE.
- You may need to decrease the time from that recommended in traditional recipes or reduce the baking time. For foods with a baking time of over an hour, reducing both the temperature and time slightly may give the best results.
- Use BAKE CONVECTION at a low temperature: between WARM and 200°F - for drying fruit, vegetables and herbs.

Ideal for single shelf baking that takes less than an hour to cook - foods such as muffins, English scones, cupcakes and enchiladas.

OVEN MODES

TRUE CONVECTION (some models only)

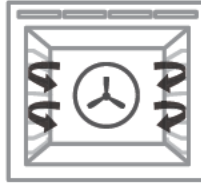

- By using the central rear heating element and fan, hot air is blown into the cavity, providing a consistent temperature at all levels, making it perfect for multi-shelf cooking.
- Trays of cookies cooked on different shelves are crisp on the outside and chewy in the middle.
- Meat and poultry are deliciously browned and sizzling while remaining juicy and tender.
- Casseroles are cooked to perfection and reheating is quick and efficient.
- When multi-shelf cooking it is important to leave a gap between trays (eg use shelves 2 & 4) to allow the air to move freely. This enables the browning of foods on the lower tray.
- If converting a recipe from BAKE to TRUE CONVECTION, we recommend that you decrease the bake time or decrease the temperature by approximately 70°F / 20°C.
- For items with longer bake times (eg over an hour) it may be necessary to decrease both time and temperature.

Ideal for multi-shelf cooking of foods such as meat, casseroles, cookies, English scones, muffins and cupcakes.

BROIL

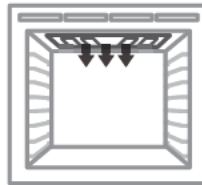

- Intense radiant heat is delivered from the top cavity area.
- Preheating is not essential although some people prefer to allow the element to heat for a few minutes before they place food under the broil element.
- The most suitable mode for 'finishing off' many meals, for example browning the top of potato gratin and frittata.

Ideal for toasting bread or for top browning to 'finish off dishes'.

OVEN MODES

BROIL CONVECTION (some models only)

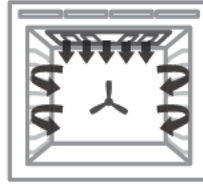

- This mode uses the intense heat from the upper cavity area for top browning and the fan to ensure even cooking of foods.
- Meat, poultry and vegetables cook beautifully; food is crisp and brown on the outside while the inside remains moist and tender.

Ideal for whole chicken, tenderloin of beef or broiling your favorite chicken, fish or steak.

CLEAN

this is not a cooking mode

- The self-cleaning cycle takes care of the mess and grime that is traditionally associated with oven cleaning.
- During self-cleaning the oven reaches very high temperatures, burning off and breaking down food soils and grease deposits.
- A self-cleaning cycle lasts about 5 hours, with an additional cool-down time of up to 30 minutes.
- See 'Using the CLEAN cycle' in the User guide for details.

COOKING CHARTS

- Shelf positions are counted from the base up (1 is the lowest, 5 is the highest).
Position shelves before you turn the oven on.
- For best results preheat the oven to the required temperature.
- The broil element may come on while the oven is heating up.
- The halo on the temperature dial will change from white to orange when the oven has reached the selected temperature. The halo may change between white and orange as the oven maintains its set temperature.

BAKING

FOOD	SHELVES	
Biscuits	Plain	Single
		Multi
	Chewy Choc Chip	Single
		Multi
	Sugar Cookies	Single
		Multi
Cakes	Pound Cake	Single
	Chocolate Brownie (8"x8"/20x20cm pan)	Single
	Angel Food Cake (10"x4"/25x10cm tube pan)	Single
	Rich Fruit Cake	Single
	Sponge (single large)	Single
	Sponge (2x20cm)	Single
Muffins / Cupcakes	Cupcakes	Single
		Multi
	Muffins	Single
		Multi
Scones	English Scones	Multi
Meringues	Meringues	Single
Bread/Bread rolls	Sandwich Loaf (9"x5"/23x13cm Loaf Pan)	Multi
	Wholewheat Loaf (9"x5"/23x13cm Loaf Pan)	Single
	Soft Dinner Rolls	Single
	Dough Proof	Single
Pastry	Pastry Shell (baked blind)	Single
Pies	Fruit Pie (2 crust)	Single
	Baked Cheesecake (in water bath)	Single
	Pumpkin Pie (blind bake, add filling)	Single
	English Custard Tart (blind bake, then add filling)	Single
Dessert	Crème Brulee (in water bath)	Single
	Crème Caramel (in water bath)	Single

COOKING CHARTS

The information in these charts are guidelines only. Refer to your recipe or the packaging and be prepared to adjust the cooking times and settings accordingly.

RECOMMENDED MODE	SHELF POSITIONS	TEMP (°F)	TEMP (°C)	TIME (MINS)
Bake Convection	3	400 - 425	210 - 220	8 - 10
True Convection	2 & 4	425 - 450	215 - 230	10 - 12
Bake Convection	3	355 - 375	180 - 190	10 - 15
True Convection	2 & 4	325 - 340	160 - 170	10 - 15
Bake Convection	4	350 - 375	175 - 190	7 - 15
True Convection	2 & 4	325 - 350	160 - 175	7 - 15
Bake	3	325	160	70 - 80
Bake	3	350	175	20 - 25
Bake	3	325 - 350	160 - 175	50 - 60
Bake	3	275 - 300	135 - 150	3 - 6 hrs
Bake	3	350	175	30 - 40
Bake	3	350	175	15 - 25
Bake Convection	3	365	185	13 - 18
True Convection	1 & 4	345	170	13 - 18
Bake Convection	3	345	170	23 - 30
True Convection	1 & 4	345	170	23 - 30
Bake	3	425 - 450	215 - 230	10 - 12
Bake	3	250 - 270	120 - 130	60 - 70
Bake	3	350	175	40 - 50
Bake	3	375	190	35 - 45
Bake	3	375	190	15 - 18
Proof	2	LO	LO	30
Bake Convection	3	350	175	15
Bake Convection	3	400 - 350	200 - 175	20 - 25
Bake	2	325	160	50 - 60
Bake	3	350 - 375	175 - 190	15 - 30
Bake	3	350 - 300	175 - 150	15 - 30
Bake	2	275	135	35 - 45
Bake	2	350	175	35 - 45

COOKING CHARTS

SAVOURY

FOOD	SHELVES
Cornbread	Single
Vegetables	Single
Lasagne	Single
Casserole	Single
Pizza	Single
Quiche (blind bake, then add filling)	Single
Potatoes (whole, baked)	Single
Frittata (shallow)	Single
Oven Meals	Single

ROASTING

FOOD	SHELVES *	RECOMMENDED MODE
Beef (Boneless)	Rare	Bake / Broil Convection
	Medium	Bake / Broil Convection
	Well Done	Bake / Broil Convection
Prime Rib Roast	Rare	Bake / Broil Convection
	Medium	Bake / Broil Convection
	Well Done	Bake / Broil Convection
Lamb Rack	Single	Bake
Lamb leg (Bone in)	Medium	Bake
	Well Done	Bake
Lamb leg (Boneless)	Medium	Bake / Broil Convection
	Well Done	Bake / Broil Convection
Veal	Medium	Bake
	Well Done	Bake
Chicken	Whole Unstuffed	Bake / Broil Convection
	Whole Stuffed	Bake / Broil Convection
	Whole Butterflied	Bake / Broil Convection
Turkey (Whole)	Stuffed	Bake
	Unstuffed	Bake
Pork (Boneless)	Medium	Bake / Broil Convection
	Well Done	Bake / Broil Convection
Pork Crackling	Crisp (watch closely)	Broil / Broil Convection
Venison	Brown in a pan first	Bake / Broil Convection
	Rare	Bake / Broil Convection
	Medium	Bake / Broil Convection

COOKING CHARTS

RECOMMENDED MODE	SHELF POSITIONS	TEMP (°F)	TEMP (°C)	TIME (MINS)
Bake Convection	3	400 - 425	210 - 215	20 - 25
Bake Convection	3	350 - 375	175 - 190	30 - 50
Bake Convection	3	350 - 375	175 - 190	35 - 40
Bake	2	300 - 350	150 - 175	1 - 2 hours
Bake	1	425	220	10 - 15
Bake Convection	3	350	175	15 - 30
Bake	3	390	200	50 - 60
Bake Convection	3	340 - 360	170 - 180	15 - 20
True Convection	3	340 - 375	170 - 190	30 - 40

SHELF POSITIONS	TEMP (°F)	TEMP (°C)	TIME (MINS)	MEAT PROBE (°F) **	MEAT PROBE (°C) **
2	320 - 340	160 - 170	18-32 /450g	130 - 138	54 - 59
2	320 - 340	160 - 170	25-40 /450g	140 - 165	60 - 74
2	320 - 340	160 - 170	30-55 /450g	165 - 174	74 - 79
2	320 - 340	160 - 170	15-30 /450g	130 - 138	54 - 59
2	320 - 340	160 - 170	20-35 /450g	140 - 165	60 - 74
2	320 - 340	160 - 170	25-40 /450g	165 - 174	74 - 79
2	390	200	20	122	50
2	320 - 340	160 - 170	18-28 /450g	149 - 158	65 - 70
2	320 - 340	160 - 170	20-33 /450g	165 - 174	74 - 79
2	320 - 340	160 - 170	20-35 /450g	149 - 158	65 - 70
2	320 - 340	160 - 170	25-45 /450g	170 - 174	77 - 79
2	320 - 340	160 - 170	20-40 /450g	160	71
2	320 - 340	160 - 170	25-45 /450g	170	76
2	350	175	15-20 /450g	165	75
2	350	175	17-22 /450g	165	75
2	350	175	40-50	165	75
1 or 2	320 - 340	160 - 170	17-22 /450g	165	75
2 or 2	300 - 330	150 - 165	15-20 /450g	165	75
3	340 - 350	170 - 175	25-40 /450g	145 - 154	63 - 68
3	340 - 350	170 - 175	30-45 /450g	165 - 174	74 - 79
3 or 4	430	220	5 to 10	na	na
3	435	225	7 /2.5cm meat thickness	120 - 129	49 - 54
3	435	225	9 /2.5cm meat thickness	131 - 140	55 - 60

** The internal temperature will rise more on standing.

COOKING CHARTS

BROILING

FOOD		SHELVES	
Beef	Steak	Rare	Single
		Medium	Single
	Hamburger (ground - patties)		Single
	Meatballs (ground)		Single
Lamb Chops		Medium	Single
		Well done	Single
Pork	Chops (well done)		Single
	Ham steak		Single
	Bacon		Single
Chicken	Boneless pieces		Single
	Bone In Pieces		Single
Sausages	Sausages		Single
Fish	Fillets		Single
	Whole		Single
Vegetables	Sliced		Single

COOKING CHARTS

RECOMMENDED MODE	SHELF POSITIONS	TEMP (°F)	TEMP (°C)	TIME (MINS)
Broil	4	HI	HI	8 - 10
Broil	4	HI	HI	10 - 15
Broil	3	HI	HI	12 - 15
Broil	3	HI	HI	12 - 15
Broil	4	HI	HI	15 - 20
Broil	4	HI	HI	20 - 25
Broil	3	HI	HI	15 - 20
Broil	3	HI	HI	15 - 20
Broil	3	HI	HI	4 - 7
Broil Convection	3	350	175	30 - 40
Broil Convection	3	350	175	40 - 50
Broil	3	HI	HI	10 - 15
Broil Convection	3	390 - 430	200 - 220	8 - 12
Broil Convection	3	390 - 430	200 - 220	15 - 20
Broil Convection	3	HI	HI	8 - 12

Using the cooktop burners

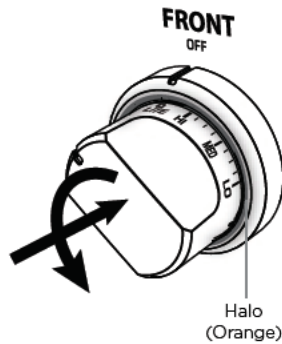
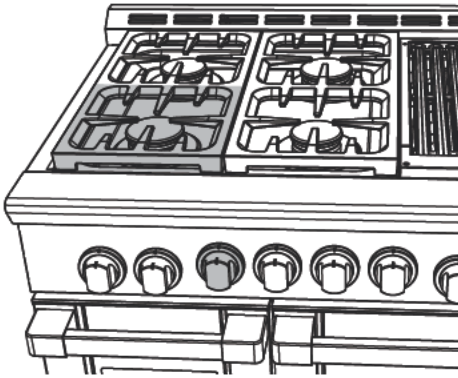

- ① Identify the knob of the burner you want to use.

- ② Push the knob in and turn it counterclockwise to LITE.
- Make sure you stop at LITE before turning the knob to any flame setting.
 - The halo will glow orange.
 - You will start hearing a clicking sound. If there is no clicking, turn the knob clockwise back to OFF and see 'Troubleshooting' for advice.

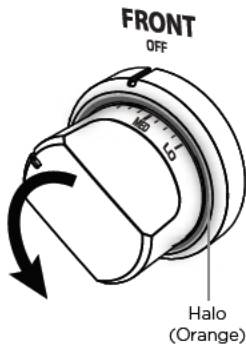

- ③ When the burner has lit, turn the knob to any setting between HI (high) and SIM (simmer).
- The clicking should stop as soon as the burner has lit.
 - If the burner doesn't light, and/or the clicking doesn't stop, or the flames are not blue and well-defined, turn the knob clockwise back to OFF and see 'Troubleshooting' for advice.

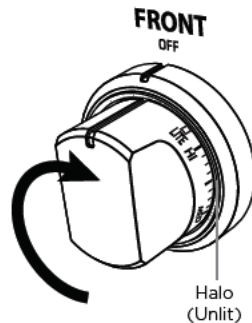

- ④ When you have finished cooking, turn the knob clockwise back to OFF.
- The knob will release and the burner and halo will go out.
 - If you are using LP gas, there may be a slight 'extinction pop' or flash at the flame spreader a few seconds after the burner has been turned off. This is normal for LP gas.

Guidelines for using the cooktop burners

- All burners have the same low turn-down setting (SIM) for gentle simmering (1,300 BTU/hr). Use the SIM setting for melting chocolate and butter, cooking rice and delicate sauces, simmering soups and stews, and keeping cooked food hot.
- For cooking that requires especially intense heat (eg searing meat, wok-cooking, stir-frying), use the burners listed below, as these have a higher maximum output (23,500 BTU/hr for Natural gas) than the other burners (18,500 BTU/hr for Natural gas).
 - *RGV2-305 / RDV2-305 and RGV2-485GD / RDV2-485GD models: **Center burner***
 - *RGV2-488/RDV2-488 and RGV2-366/RDV2-366 MODELS: **Front left burner or front right burner***
 - *All other models: **Front left burner***
- Never leave the cooktop unattended when in use. Boilover causes smoking and greasy spills that may ignite.
- Never allow flames to extend beyond cookware or curl up its sides. This could discolor and damage the utensil and you may get burned touching a hot handle.
- Keep handles out of the way. Turn handles so that they don't extend over the edge of the cooktop or another burner that is on.
- Take care when deep-frying. Oil or fat can overheat very quickly, particularly on a high setting.
- Make sure that all burner parts are properly in place. Incorrectly or incompletely assembled burners may produce dangerous flames. See 'Replacing the burner parts' in 'Care and cleaning'.
- Keep the burners clean. Especially after a spill or boilover, make sure you clean the affected burners before using them again. Food residue may clog the ignitor and the notches of the flame spreader, stopping the burner from functioning correctly. See 'Care and cleaning' for instructions.
- Check that the burner flames are regular. They should be blue with no yellow tipping, and burn without fluttering all around the burner cap. If not, see 'Troubleshooting' for advice.
- Use woks only with a wok ring. Wok rings can be purchased separately through your Fisher & Paykel dealer or Customer Care. To use, place the wok ring over the grates, making sure the small protrusions on its bottom straddle the grate fingers. The wok ring should be stable and unable to rotate.

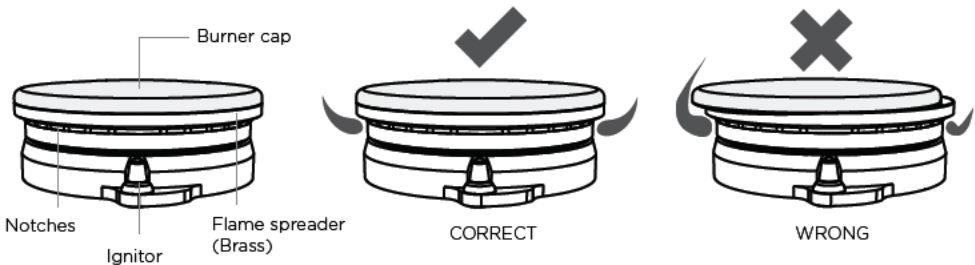

COOKTOP USE

Using the grill

The grill has a reversible grate. It will change color with use as oils cook onto the surface. This is normal and doesn't affect grilling performance.

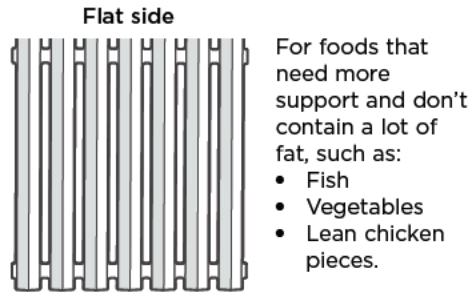
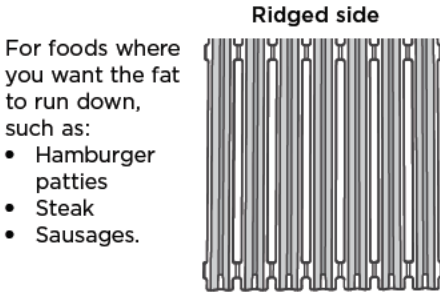

To use the grill

- ① Remove the cover and check that the grease drip-pan and the grill grate are properly in place and you have the best side for your food. The grate should always be sloping towards the grease drip-pan, with its support bar firmly resting in the groove of the rear ledge, as shown.

IMPORTANT!

Never turn on or use the grill with the grill cover in place.

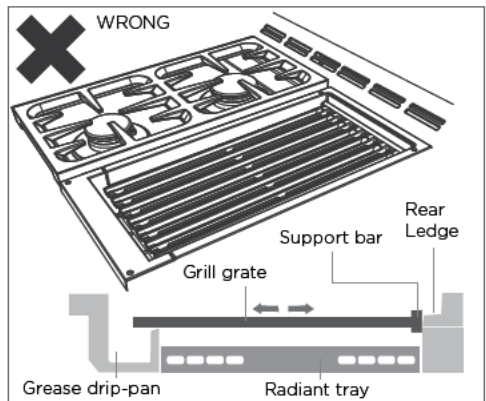
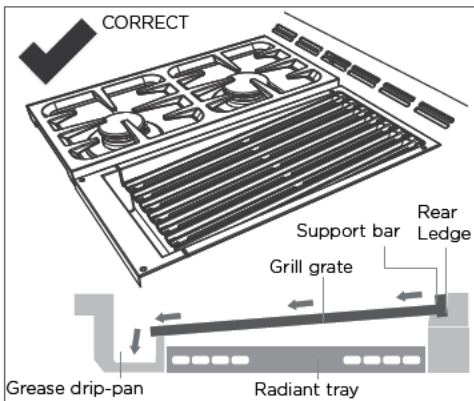

- ② Turn the grill knob counterclockwise to the LITE/HI setting.
 - The halo around the knob will glow orange.
 - There may be a delay of a minute or so before the grill burner lights. This is normal.
- ③ Allow the empty grill to heat up for about 15 minutes.
- ④ Adjust the heat anywhere between HI (high) and LO (low) during grilling.
- ⑤ When you have finished using the grill, turn the grill knob clockwise back to OFF.
- ⑥ Clean the grill grate immediately after use. See 'Care and cleaning' for instructions.
- ⑦ When the grill has cooled down, clean the grease drip-pan. See 'Care and cleaning' for instructions.

Grill cooking guidelines

IMPORTANT!

- **Never leave the grill unattended during use. Grease drippings may cause short flare-ups or even sustained flaming. If left unattended, these may cause fire.**
- **Make sure you have your ventilation hood set on maximum during grilling.**
- **Clean the grease drip-pan after every use. Accumulated grease can be a fire hazard.**
- The longer you preheat the grill, the darker the grill marks will appear on food.
- Trim excess fat off meat to minimize flare-ups.
- Generally, start out on a high setting to sear or brown meat, then lower the setting to make sure that meat or poultry is cooked through.
- When turning meat over, use tongs or a spatula as these will not puncture the meat and allow the juices to run out.

Using the griddle

The griddle will darken and 'season' with use, developing a natural non-stick coating. When it is properly seasoned it can be used without any additional oil.

- ① Remove the cover and check that the grease drip-pan is properly in place.

IMPORTANT!

- **Never turn on or use the griddle with the cover in place.**
 - **Always keep the vents at the rear of the griddle frame clear of any object: airflow to the vents must not be blocked.**
- ② If you haven't used the griddle for a long time, re-season it. See section 'First use - seasoning the griddle' for instructions.
 - ③ Turn the griddle knob counterclockwise to the desired temperature.
 - There may be a delay of a minute or so before the griddle comes on. This is normal.
 - While the griddle is heating up, the halo around the knob will glow white.
 - See the 'Griddle cooking chart' below for suggestions.
 - ④ When the halo turns orange (after about 15 minutes), the griddle is ready to use.
 - Note: the halo may alternate between white and orange during use as the griddle maintains the set temperature.
 - ⑤ When you have finished using the griddle, turn its knob clockwise back to OFF.
 - ⑥ Clean the griddle and grease drip-pan after every use. The griddle should be cleaned very carefully while it is still hot. See 'Care and cleaning' for instructions.

IMPORTANT!

Clean the grease drip-pan after every use. Accumulated grease can be a fire hazard.

Griddle cooking chart

FOOD	TEMPERATURE SETTING
Eggs	225-250 °F
Bacon, ham, pork chops	300-325 °F
Sausage, grilled cheese sandwiches	325-350 °F
Pancakes, French toast	350-375 °F
Hash brown potatoes	400-425 °F

CARE AND CLEANING

DOS

- Read these cleaning instructions and the 'Safety and warnings' section before you start cleaning your range.
- Before cleaning or removing any part, make sure that everything on the range has been turned off.
- Unless suggested otherwise in the chart following, allow any part to cool to a safe temperature before cleaning. If you do need to handle a warm or hot part (eg grill or griddle), take extreme care. Wear long protective mitts to avoid burns from steam or hot surfaces.
- Try using any cleaner on a small area first, to ensure it doesn't stain.
- See the pages following this chart for instructions on removing and replacing different parts of the range for cleaning or maintenance.
- To help you identify any parts, see illustrations in section 'Introduction' and after this cleaning chart.
- Ensure the anti-tip device is re-engaged if you move the range for cleaning. Failure to do this may result in the oven tipping, and adults and children may be killed.

DON'TS

- **Do not use aerosol cleaners until the range has completely cooled.**
- **The propellant substance in these cleaners could catch fire in the presence of heat.**
- **Do not let soiling or grease accumulate anywhere in or on the range. This will make future cleaning more difficult and may present a fire hazard.**
- **Do not use any abrasive or harsh cleaners, cloths, scouring pads or steel wool. These will scratch your range and damage its appearance.**
- **Do not use a steam cleaner to clean any part of the range.**
- **Do not perform any cleaning or maintenance on parts not specifically named in the chart below. If in doubt, contact Customer Care.**
- **Do not lift the black grill and griddle frames off the cooktop.**

Manual cleaning chart

WHAT? HOW OFTEN?	HOW?	IMPORTANT!
RANGE EXTERIOR		
Door frame exterior	<ol style="list-style-type: none"> ① Soften any stubborn stains under a hot soapy cloth. ② Clean with a solution of mild detergent and hot water, then wipe dry with a microfiber cloth. ③ For extra shine, use a suitable stainless steel cleaner and polish, following manufacturer's instructions. Always rub the stainless steel in the direction of the polish lines. 	<ul style="list-style-type: none"> • Always read the label to make sure your stainless steel cleaner does not contain chlorine compounds as these are corrosive and may damage the appearance of your cooktop. • Do not use and take care not to spill any stainless steel cleaner on the knobs, oven handles, or the kickstrip grate. These are not stainless steel parts and their surface may be damaged by stainless steel cleaner. • When cleaning the back trim and the top of the oven door, be careful not to let any liquid run down the vent holes.
Control panel		
Sump area around cooktop burners		
Grill and griddle covers		
Back trim		
After every use		

CARE AND CLEANING

WHAT? HOW OFTEN?	HOW?	IMPORTANT!
Control knobs Oven handles Kickstrip grate	<p>① Wipe with a damp cloth using a solution of mild detergent and hot water.</p> <p>② Dry thoroughly with microfiber cloth.</p> <p>If washed, the knobs can be removed for cleaning. Before removing a knob, make sure that it is set to OFF, then pull it straight towards you. Remove only one knob at a time, and make sure that you refit it on its shaft completely and correctly after cleaning.</p>	<ul style="list-style-type: none"> • Do not use stainless steel cleaner on these parts, as doing so may damage their coating. • The knobs are not interchangeable: if you remove them for cleaning, do so one at a time. This is to ensure that you replace each knob exactly where you removed it from.
OVEN PARTS		
Enamel oven interior - <i>light soiling</i>	<p>① Wipe with a damp cloth and a solution of hot water and mild detergent.</p> <p>② Wipe dry with a soft cloth.</p> <p>Note: the oven door may be removed to make reaching into the oven easier.</p>	<p>To prevent soiling from becoming 'baked on' and stubborn, we recommend removing any easy-to-reach spills, food or greasy stains from the enamel after each use. In self-cleaning ovens, this will also reduce the need for using the CLEAN cycle frequently.</p>
Enamel oven interior - <i>stubborn, 'baked-on' soiling</i>	<ul style="list-style-type: none"> • Self-cleaning ovens (those with CLEAN on the oven mode knob): use the CLEAN cycle. See 'Using the CLEAN cycle' for instructions. • Non-self-cleaning ovens (those without CLEAN on the oven mode knob): <ol style="list-style-type: none"> ① Remove everything from the oven: shelves, side racks, all utensils. ② Cover the kickstrip grate and the floor in front of the oven with several layers of newspaper. This is to protect these surfaces from damage by oven cleaner seeping out or accidentally dripping on them. ③ Apply an ammonia-based cleaner or oven cleaner following the cleaner manufacturer's instructions. ④ After cleaning, replace the side racks and shelves. 	<ul style="list-style-type: none"> • Don't use oven cleaners in self-cleaning ovens (those with CLEAN on the oven mode knob). • Oven cleaners are caustic and may permanently stain or damage some surfaces. When using an oven cleaner in a non-self-cleaning oven, take care not to let it come in contact with any surface other than the oven interior. If it accidentally does, remove immediately.

CARE AND CLEANING

WHAT? HOW OFTEN?	HOW?	IMPORTANT!
OVEN PARTS		
Side racks	<ul style="list-style-type: none"> Pre-soak any stubborn, burnt-on soiling, then clean with a solution of mild detergent and hot water and wipe dry with a microfiber cloth. Alternatively, clean these in the dishwasher. 	
Oven shelves	<ol style="list-style-type: none"> To remove stubborn or 'baked-on' soiling, scrub with a dampened, soap-filled, non-metal, non-abrasive pad, then wipe dry. Apply a chrome cleaner with a damp sponge or cloth following manufacturer instructions. Wipe and dry. 	Do not wash the main oven shelves in the dishwasher, immerse them in soapy water, or use oven cleaner on them. Doing so will remove the lubricating grease in the slides, stopping them from running smoothly.
Broil pan and rack	<ol style="list-style-type: none"> Pre-soak any stubborn soiling in a solution of mild detergent and hot water. Wash by hand or in a dishwasher. 	
Bake and broil burners <i>(gas ovens)</i>	Do not clean these parts. They self-clean during normal use.	
Broil element <i>(electric ovens)</i>		
Oven door glass (interior)	<ul style="list-style-type: none"> Self-cleaning ovens (those with CLEAN on the oven mode knob): This will be cleaned during a CLEAN cycle. However, if it is particularly soiled, wipe down with hot water to loosen stains before starting a CLEAN cycle. Non-self-cleaning ovens (those without CLEAN on the oven mode knob): Use a soft cloth and a mixture of warm water and dishwashing liquid to remove light soiling. For stubborn stains, try using a ceramic cooktop cleaner or a mixture of baking soda and warm water, then wipe dry with a soft, lint-free cloth. 	Do not use oven cleaners or any other harsh/abrasive cleaners, cloths, scouring pads, steel wool or sharp metal scrapers to clean the oven door glass. These scratch the glass, which in turn could result in the glass cracking and shattering.
Oven door glass (exterior)	Clean using a soft cloth and a mixture of warm water and dishwashing liquid or glass cleaner.	

CARE AND CLEANING

WHAT? HOW OFTEN?	HOW?	IMPORTANT!
OVEN PARTS		
Oven door gasket	<p>Avoid cleaning this part. If you need to remove large food particles off it, proceed as follows:</p> <ol style="list-style-type: none">① Dampen a sponge with clean hot water.② Gently wipe off the soiling, but do not rub.③ Press a dry towel gently on the gasket to dry.	<ul style="list-style-type: none">• Do not use any cleaning agent on the gasket.• The gasket is essential for a good seal. Take care not to rub, displace, or damage it.
COOKTOP PARTS		
Burner caps and brass flame spreaders	<ol style="list-style-type: none">① Check that the burner is turned OFF and allow it to cool.② Lift off the burner cap and brass flame spreader.③ Wash them in hot soapy water, rinse, and dry.<ul style="list-style-type: none">• Use a stiff nylon brush or straight-ended paper clip to clear the notches of the flame spreader.④ Replace the flame spreader and burner cap correctly. See 'Replacing the burner parts'.	<ul style="list-style-type: none">• Keep the notches of the flame spreaders clear. Soiling may clog these and cause ignition problems.• Before replacing the burner parts, check that they are dry. Wet burner parts may result in an irregular flame.• Before lighting a burner you have reassembled, check that all of its parts are positioned correctly. Incorrect assembly can cause dangerous irregular flames and ignition problems.
Ignitors	<ol style="list-style-type: none">① Check that the burner is turned OFF.② Clean the ignitor with a small brush (eg old toothbrush) or cotton swab that has been dipped into rubbing alcohol.	<p>The ignitors must be kept clean and dry to work correctly. Dirty or wet ignitors could cause constant clicking and sparking, even if a flame is present.</p>
Burner grates	<ol style="list-style-type: none">① Wait until the grates have cooled completely.② Carefully lift the grates off the cooktop and place them on a protected surface.③ To remove stubborn stains, soak the grates in a mixture of clothes washing detergent and water.④ Wash in a mixture of hot water and dishwashing liquid, then rinse and allow to dry. <ul style="list-style-type: none">• The grates are also dishwasher safe.	<ul style="list-style-type: none">• Take care, the grates are heavy.• Make sure you place a dish towel or other soft cover on the surface before putting a grate on it.

CARE AND CLEANING

WHAT? HOW OFTEN?	HOW?	IMPORTANT!
Grill grate	<ol style="list-style-type: none">① Check that the grill has been turned off.② Put on barbecue mitts for protection against steam and heat.③ Scrub the grill with a brass bristle barbecue brush dipped frequently into a bowl of warm water. The softened food particles will drop onto the radiant tray below the grate.④ Once the grate has cooled completely, remove it and wash in the sink with hot soapy water.⑤ Dry with a soft cloth, then replace.	<ul style="list-style-type: none">• The grill grate should be cleaned immediately after use (while it is still hot), so that food particles do not become ‘baked-on’ and hard to remove.• The grill grate will change color with use. This is normal.• To ensure that you replace the grill grate correctly, see illustrations in section ‘Using the grill’.
Radiant tray (under grill grate)	<ol style="list-style-type: none">① Wait until the grill has completely cooled.② Lift off the grill grate, lift out the grease drip-pan, then carefully lift out the radiant tray.③ Shake it gently over a sheet of newspaper or waste bin to empty it of ash and food particles.④ Replace the tray, making sure that the tab with the hole is at the front of the cooktop.⑤ Replace the grease drip-pan and the grate.	<ul style="list-style-type: none">• The radiant tray doesn’t need regular cleaning. Clean only if there’s evidence of large food particles.• The radiant tray doesn’t need cleaning with water, as smaller soiling will be burned off during use.• Make sure you replace the radiant tray correctly: the tab with the hole must be at the front.

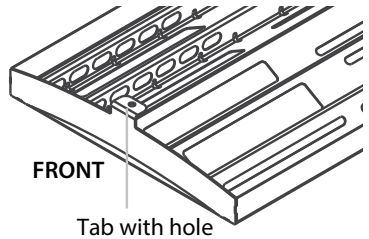

CARE AND CLEANING

WHAT? HOW OFTEN?	HOW?	IMPORTANT!
Griddle	<p>To remove light soiling after each use:</p> <ol style="list-style-type: none"> ① While the griddle is still hot, use a square-edged spatula or brass brush to clean the griddle of grease and food particles. ② Once the griddle has cooled to lukewarm, rub the surface lightly with vegetable oil, then wipe thoroughly with a heavy, coarse cloth. <p>To remove stubborn, 'baked-on' soiling:</p> <ol style="list-style-type: none"> ① Use a griddle stone following manufacturer's instructions, taking care to avoid the griddle's black frame. ② Wash with hot soapy water, rinse and dry. ③ Re-season the griddle following instructions in section 'First use – seasoning the griddle.' 	<ul style="list-style-type: none"> • Take extreme care while cleaning a hot griddle: wear barbecue mitts and be careful of steam and hot surfaces. • Never flood the hot griddle with cold water: this could cause it to crack or warp. • Do not lift the black griddle frame off the cooktop. The griddle assembly must not be removed. • The griddle will develop a non-stick coating and will darken or discolor in patches with use: this is normal.
Grease drip-pan	<ol style="list-style-type: none"> ① Wait until the grease drip-pan has cooled to a safe temperature to touch, then slide it slightly towards you and lift out. ② Discard grease, then clean the drip-pan with hot water and dishwashing liquid. The grease drip-pan is also dishwasher-safe. ③ Rinse with clean water and allow to dry. ④ Replace the clean grease drip-pan. 	<p>Do not use abrasive cleaners or scouring pads as they may damage the coating.</p>
Black frame of grill and griddle	<ol style="list-style-type: none"> ① Soften any stubborn stains under a hot soapy cloth. ② Clean with a solution of mild detergent and hot water, then wipe dry with a microfiber cloth. 	<ul style="list-style-type: none"> • Do not lift the frame off the cooktop. • Do not use abrasive cleaners or scouring pads as they may damage the coating.
Wok ring (not supplied, purchased separately)	<ol style="list-style-type: none"> ① To remove stubborn stains, soak the wok ring in a mixture of clothes washing detergent and water. ② Wash in a mixture of hot water and dishwashing liquid, then rinse and allow to dry. <ul style="list-style-type: none"> • The wok ring is also dishwasher-safe. 	

CARE AND CLEANING

Removing and replacing the oven door

IMPORTANT!

- Do not lift the oven door by its handle. Doing so may damage the door.
- Make sure the oven and the door are cool before you begin to remove the door.
- Before removing the door, make sure there is a large enough clear, protected surface in the kitchen to rest the door on.
- Take care, the oven door is heavy!

To remove the oven door

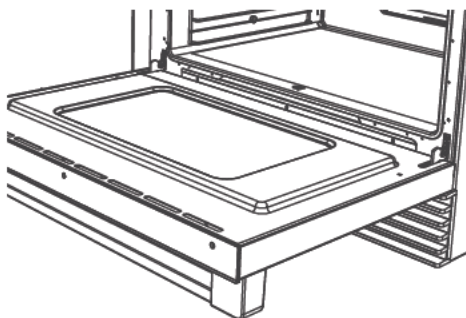

- ① Open the door fully.

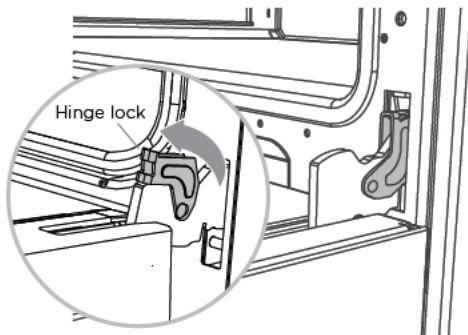

- ② Open the hinge locks fully on both sides.

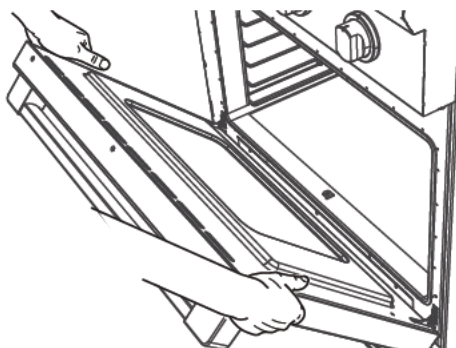

- ③ Holding the door firmly on both sides, gently close it about halfway.

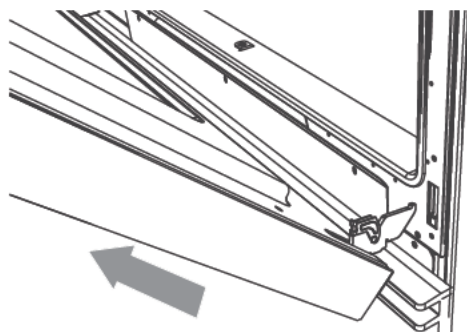

- ④ Disengage the hinges and remove the door. Place on a protected surface.

CARE AND CLEANING

To replace the oven door

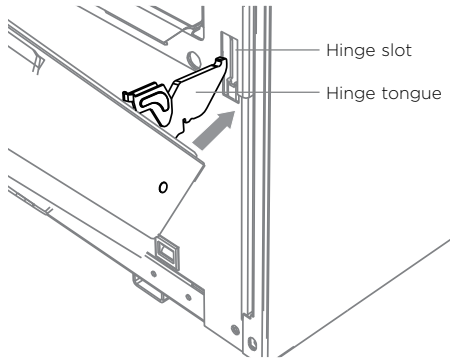
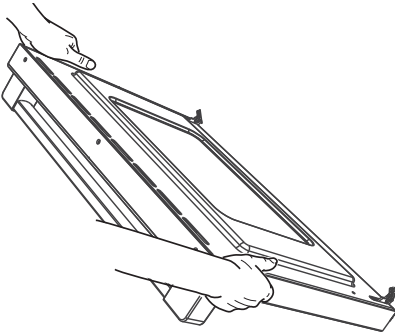

- ① Hold the door firmly in an approximately halfway open position.
- ② Align the hinge tongue with the hinge slots and push the door until you feel the latches locate into position on each side.

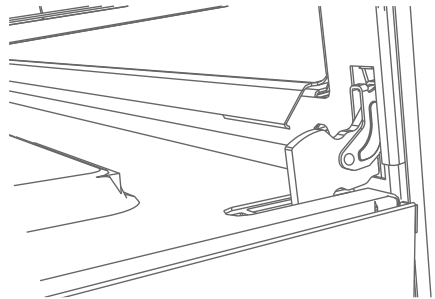
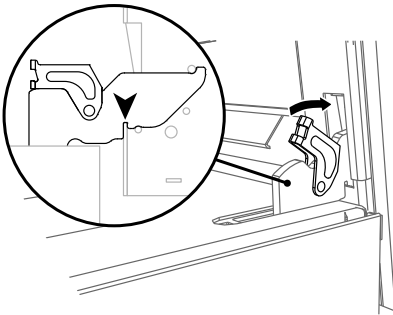

- ④ Open the door completely and check that the hinges are both secured by the correct notches as shown.
- ⑤ Rotate the locks into the closed position.
- ⑥ Close the oven door.

IMPORTANT!

Hinge locks should rest inside the slots. Incorrect installation will prevent door from correctly sealing.

CARE AND CLEANING

Removing and replacing the side racks

To remove side racks

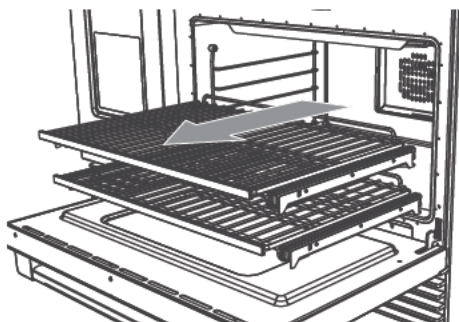

- 1 Remove any shelves first. See section 'Positioning the shelves' for instructions.

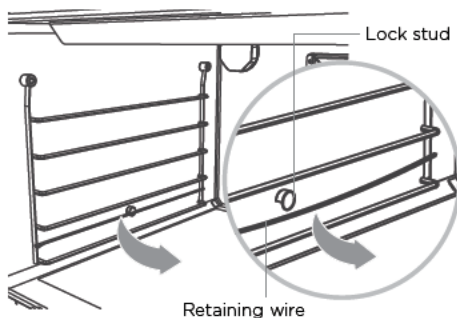

- 2 Gently pull down on the retaining wire from underneath the lock stud. The retaining wire will pop out.

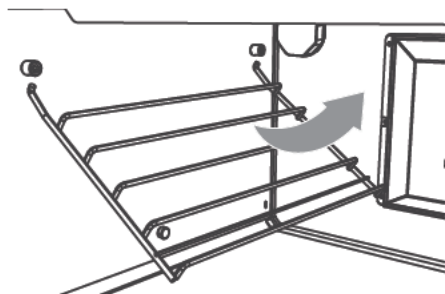

- 3 Swing the bottom of the side rack up towards the center of the oven until it is almost horizontal.

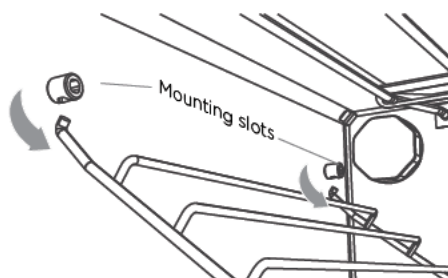

- 4 Slide the prongs at the top out of the mounting slots.

To replace side racks

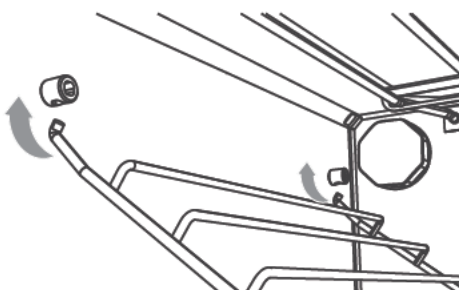

- 1 Supporting the side rack with your hand from underneath, hold it almost horizontally and locate the prongs into the mounting slots.

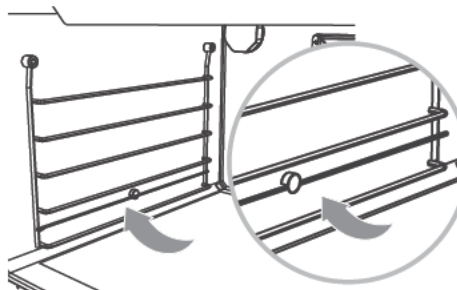

- 2 Ensure the prongs are fully inserted into the slots, then lower the side rack carefully and gently push the retaining wire underneath the lock stud.

CARE AND CLEANING

Replacing the burner parts

IMPORTANT!

When replacing the burners, make sure that the two locating pins on the bottom of the brass flame spreader are properly aligned with the locating pin holes on the top of the simmer ring. Incorrect alignment will produce a potentially dangerous flame and poor burner performance.

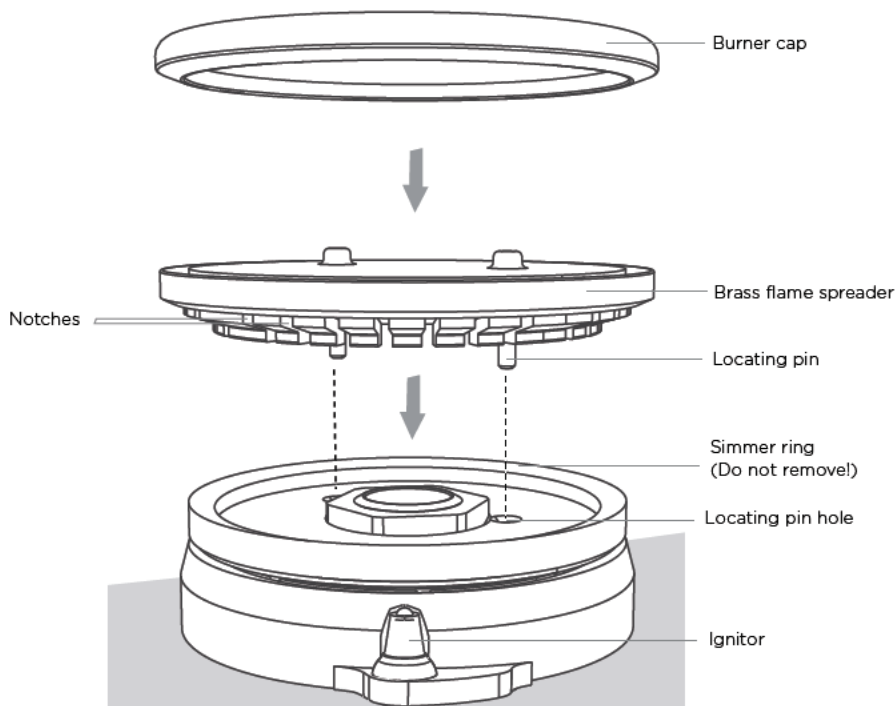

CARE AND CLEANING

Replacing the oven light bulb

IMPORTANT!

Use a 40 W, 120 V appliance light bulb for replacement. Do not use a standard light bulb in any oven, the heat will break it.

- ① Allow the oven (including the lamp cover and the bulb) to cool completely.
- ② Remove any shelves that may get in the way.
- ③ Remove the door if the lamp will be hard to reach.
- ④ Turn the power supply to the range off at the main fuse or circuit breaker panel. If you don't know how to do this, contact an electrician.

IMPORTANT!

Failure to disconnect the range from the power supply may result in death or electrical shock.

- ⑤ Remove the lamp cover: turn it counterclockwise to unscrew.
- ⑥ Remove the faulty bulb and replace with a new 40 W appliance light bulb.
- ⑦ Replace the lamp cover: turn it clockwise to tighten.
- ⑧ Turn the power supply to the range back on at the main fuse or circuit breaker panel.

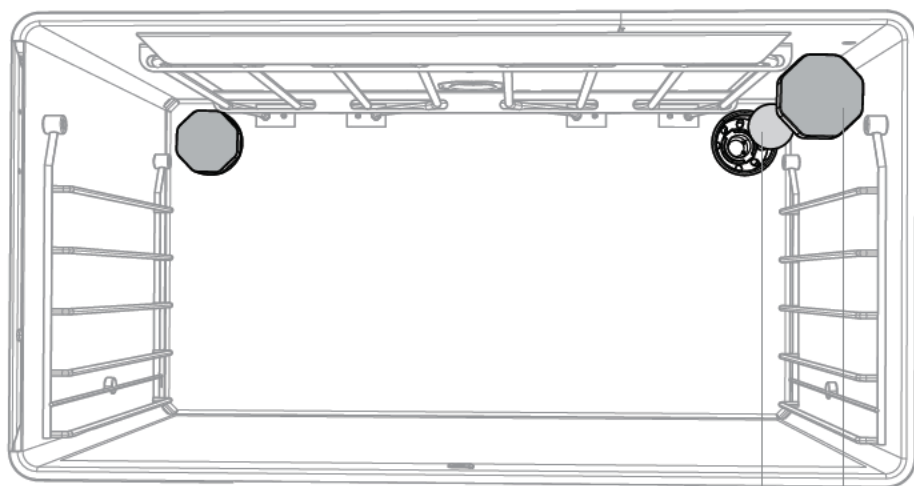

Light bulb Lamp cover

CARE AND CLEANING

Using the CLEAN cycle

About the CLEAN cycle

- Main ovens in RDV2 models feature a self-cleaning cycle (CLEAN) which takes care of the mess and grime that is traditionally associated with oven cleaning. During self-cleaning, the oven reaches very high temperatures. This burns off and breaks down food soils and grease deposits. All that remains is a clean oven cavity with a little gray ash which you can easily remove.
- A CLEAN cycle lasts about 5 hours, plus an additional cool-down time of up to 30 minutes (this may vary). During a CLEAN cycle, the oven door will be locked and only the cooktop burners may be used. The secondary oven, grill, and griddle cannot be used.
- A CLEAN cycle is designed to clean the oven interior and the portion of the door exposed to the oven interior. The outer edge of the door and the oven frame will need to be cleaned manually.
- During a CLEAN cycle you may see occasional, brief glowing in the oven as soiling is getting incinerated, especially if the oven was heavily soiled. This is normal. However, if there is excessive smoking or you see flames in the oven, cancel the cycle, wait for the oven to cool down completely, then wipe up the excessive food soil. See 'To cancel a CLEAN cycle' for instructions.

IMPORTANT!

- **Do not use oven cleaners, any degreasing cleaners, or oven liners in a self-cleaning oven.**
- **If there are cracks or flaws in the oven door glass, if the oven gasket is damaged, stiff, or worn, or if the door does not close properly, do not start a CLEAN cycle. Call your Authorized Service Center or Customer Care.**
- **Make sure you remove the side racks, oven shelves, broiler pan, and all other bakeware and utensils from the oven before starting a CLEAN cycle. If left in the oven, they will become permanently discolored or damaged; items made from combustible materials (eg wood, fabric, plastic) may even catch fire.**
- **Do not use your oven to clean miscellaneous parts.**
- **Before starting a CLEAN cycle, wipe up any spills or grease deposits and remove any loose food soiling. Failure to do so may discolor the oven surfaces and cause excessive smoking during the cycle.**
- **Before starting a CLEAN cycle, make sure you move any pet birds to another, closed and well-ventilated room. Some pet birds are extremely sensitive to the fumes given off during self-cleaning, and may die if left in the same room as the oven during such a cycle.**
- **Make sure the room is well ventilated during the CLEAN cycle. Turn the ventilation hood above the range on maximum and leave it on for the duration of the cycle.**
- **During a CLEAN cycle, the oven reaches higher temperatures than it does for cooking. Under such conditions, the surfaces may get hotter than usual and children should be kept away.**

CARE AND CLEANING

To start a CLEAN cycle

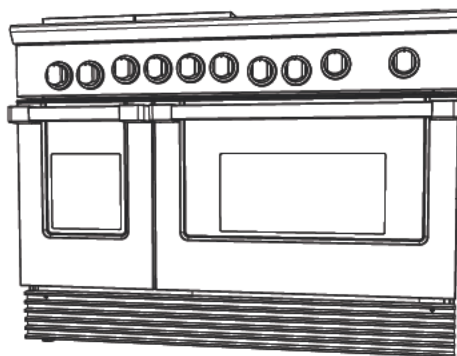
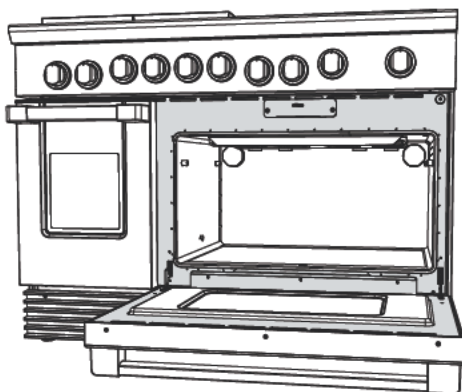

- ① Remove oven shelves, side racks and all other accessories, bakeware, and utensils. See 'Removing and replacing the side racks' and 'Positioning the shelves' for instructions.
- ② Wipe up any spills or grease deposits and remove any loose food soiling. Failure to do so may discolor the oven surfaces and cause excessive smoking during the cycle.
- ③ Check that the lamp covers are in place.
- ④ If there is soiling on the oven frame or the outer edge of the door interior (the shaded areas shown above), clean these using a soap-filled non-abrasive pad, then wipe with a clean damp cloth.
- ⑤ Close the oven door firmly.
- ⑥ Turn the ventilation hood above the range on maximum, and leave it on for the duration of the cycle.

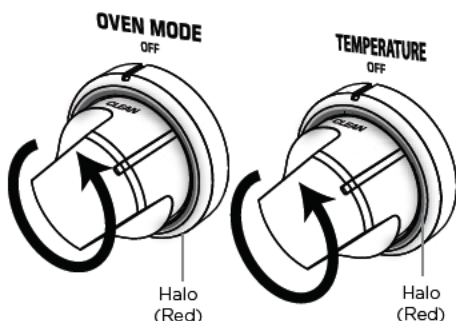

- ⑦ Turn the oven mode knob counterclockwise to CLEAN.
 - Its halo will glow red.
- ⑧ Turn the temperature knob counterclockwise to CLEAN.
 - Its halo will glow red.
 - The oven door will lock. For your safety, the door will remain locked during the clean cycle, until the oven has cooled to a cooking temperature.
 - Both halos will remain red during the clean cycle, and will go out when the cycle has finished.

When a CLEAN cycle has finished

Once the oven has cooled to a cooking temperature, the halos around the function and temperature knobs will go out and the door will unlock.

You need to:

- ① Turn the oven mode and temperature knobs clockwise to OFF.
- This will re-enable the grill or griddle, and the secondary oven (48" models only).
- You may continue to hear the noise of the cooling fan: it is normal for the fan to stay on.

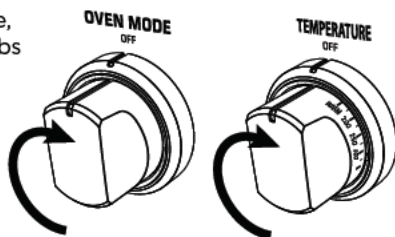

IMPORTANT!

Do not turn the power supply to the range off at the circuit breaker panel. The cooling fan is needed to cool the oven. Disconnecting the range from the power supply while the oven is too hot may damage the oven and its surrounding cabinetry.

- ② Wait until the oven door automatically unlocks.
- ③ After the door has unlocked, wait for the oven to cool down completely.

IMPORTANT!

The oven will still be at cooking temperatures when the door unlocks. Take care.

- ④ Remove any gray ash from the oven with a small brush or damp cloth.
- ⑤ Wipe out the oven with a clean, damp cloth and dry with a clean, lint-free cloth.
- ⑥ Replace the side racks and shelves. See sections 'Removing and replacing the side racks' and 'Positioning the shelves' for instructions.

To cancel a CLEAN cycle

- ① Turn the oven mode and temperature knobs clockwise to OFF.
- The halos will remain red.
- The door will remain locked. Once the oven has cooled to a cooking temperature (this may take up to 30 minutes, depending on the stage the cycle was in when canceled), the halos around the function and temperature knobs will go out and the door will unlock.
- This will re-enable the grill or griddle, and the secondary oven (48" models only).
- You may continue to hear the noise of the cooling fan: it is normal for the fan to stay on.

IMPORTANT!

Do not turn the power supply to the range off at the circuit breaker panel. The cooling fan is needed to cool the oven. Disconnecting the range from the power supply while the oven is too hot may damage the oven and its surrounding cabinetry.

- ② Wait until the oven door automatically unlocks (up to 30 minutes).
- ③ After the door has unlocked, wait for the oven to cool down completely.

IMPORTANT!

The oven will still be at cooking temperatures when the door unlocks. Take care.

- ④ If necessary, wipe up any food soiling inside the oven.
- We do not recommend cancelling a CLEAN cycle and then immediately starting one again.

TROUBLESHOOTING

If you can't find an answer to your problem in the chart below, or if the problem cannot be fixed, you will need technical help. Contact your Authorized Service Center or Customer Care.

PROBLEM	POSSIBLE CAUSES	WHAT TO DO
OVEN		
The oven doesn't work (no heating).	No power supply (oven light and halos do not come on either).	Check that the circuit breaker hasn't tripped and there is no power outage in your area. If there is a power outage, you cannot use the oven until power has been restored.
	No gas supply (gas ovens).	The supply to the house may not be working or there may be an outage. Contact your local gas supplier.
One of the oven lights does not come on, but the oven works.	The light bulb is loose.	See instructions for 'Replacing the oven light bulb' in section 'Care and cleaning'. Instead of replacing the bulb, simply ensure that it is secure in its socket.
	The light bulb has blown.	Replace the bulb. See instructions for 'Replacing the oven light bulb' in section 'Care and cleaning.'
There is a power failure – can I still use the oven?	Power outage in your home or neighborhood.	The oven cannot be used until power is restored. Once power is restored you must return the oven knobs to OFF before you can begin cooking again.

TROUBLESHOOTING

PROBLEM	POSSIBLE CAUSES	WHAT TO DO
OVEN		
Condensation around oven (eg on control panel or top of oven door.)	Food has high moisture content or local climate (temperature, humidity) is contributing to condensation.	Condensation is normal. You can wipe the drops off the control panel. If there is frequent or excessive condensation, make sure that cabinetry around the range is moisture-proofed.
Steam coming from oven vents at the back of the range.	Moisture from food evaporating during cooking.	This is normal, especially if you are cooking large quantities of food in the oven using a CONVECTION mode.
Fan noise and warm ventilation air coming from the range during and after use or a CLEAN cycle.	A cooling fan in the range runs to prevent the oven door and control panel from overheating.	This is normal and requires no action.
Occasional, brief glowing inside the oven during a CLEAN cycle.	Heavy soiling is getting incinerated.	This is normal and requires no action.
Excessive smoking and/or flames inside the oven during a CLEAN cycle.	Combustible material (eg wooden board or utensil) or excessive food soils left in the oven.	Follow the instructions under 'To cancel a CLEAN cycle' in section 'Care and cleaning'. IMPORTANT! Do not disconnect the range from the power supply at the circuit breaker. The cooling fan is needed to cool the range.
The oven door does not align with the control panel or surrounding cabinetry.	The oven door has been installed incorrectly and the hinges are misaligned within the slots.	Re-install the door. See 'Replacing the oven door' on page 41 for instructions.
Temperature is not calibrated correctly.	Door is not sealing correctly.	Re-install the door. See 'Replacing the oven door' on page 41 for instructions.

TROUBLESHOOTING

PROBLEM	POSSIBLE CAUSES	WHAT TO DO
OVEN		
The oven door won't open	The door is locked because a CLEAN cycle is underway or the oven has not yet cooled to a cooking temperature after a CLEAN cycle.	See section 'Using the CLEAN cycle' in 'Care and cleaning' for information.
The halo around the oven temperature knob alternates between white and orange during use	The oven needs to heat periodically to maintain the set temperature during use	This is normal.
The convection fan does not come on in a CONVECTION mode	Technical fault	Contact your Authorized Service Center or Customer Care.
Uneven baking	Oven not properly preheated.	Wait until the halo around the temperature knob has changed from white to orange before putting food in.
	Unsuitable or incorrectly arranged bakeware.	See 'Oven cooking guidelines' for advice.
COOKTOP BURNERS		
None of the burners, grill, or griddle will light	No power supply	Check that there is no power outage in your area and that the power supply to the range is switched on at the circuit breaker panel.
	No gas	Check that the gas supply to the house is working. You should hear the gas when you turn a burner on. If you are using bottled gas, check that it is not empty.

TROUBLESHOOTING

PROBLEM	POSSIBLE CAUSES	WHAT TO DO
COOKTOP BURNERS		
Some burners will not light	Burner parts or ignitors may be wet, dirty, or misaligned	Check that the burner parts are clean, dry, and correctly assembled. Check that the ignitors are clean and dry. See 'Care and cleaning' for instructions.
Flames do not burn all around the burner cap		
There is no clicking when I try to light a burner	The ignitor is dirty or there is a power outage	Clean the ignitor(s). See 'Care and cleaning' for instructions.
There is a power failure - can I still use the cooktop burners?	Power outage in your area	The cooktop burners can still be used. To light them: <ol style="list-style-type: none"> ① Holding a lighted match to the flame spreader, push in on the control knob and turn counterclockwise to LITE. ② When the flame is burning all the way around the burner, you may adjust the heat.
<p style="text-align: center;">IMPORTANT!</p> <p style="text-align: center;">If the flame is blown out during a power failure, turn the knob immediately to OFF, as the burner will not automatically relight and gas may escape.</p>		
The flames have suddenly gone out	A draft or a spill has extinguished the flame	No action required. The burner will detect this and automatically relight. However, if there has been a large spill, we recommend turning the burners off and cleaning the burners and sump area. See 'Care and cleaning' for instructions.
There is a slight 'extinction pop' or flash after I've turned a cooktop burner off		This is normal for LP gas and requires no action.
The burner flames are uneven, very large, yellow or yellow-tipped or sooty	Technical fault: the gas is the wrong type or hasn't been adjusted properly	Do not use your cooktop burners. Contact your Authorized Service Center or Customer Care.

TROUBLESHOOTING

PROBLEM	POSSIBLE CAUSES	WHAT TO DO
COOKTOP BURNERS		
The ignitor keeps clicking (continuous spark) even when a burner has lit	Dirty or wet ignitor(s)	Clean the ignitor(s). See 'Care and cleaning' for instructions.
GRIDDLE		
The surface is discolored in patches	Oils cook onto the surface with repeated use	This is normal and doesn't affect cooking performance.
There is a power failure - can I still use the griddle?	Power outage in your home or neighborhood	The griddle cannot be used until power is restored.
The griddle will not light; halo does not illuminate when the knob is turned	The oven is in a CLEAN cycle	Wait until the CLEAN cycle has finished, or follow the instructions under 'To cancel a CLEAN cycle in the section 'Care and cleaning'.
GRILL		
Flare-ups during grilling	Fatty cuts of meat	Minor flare-ups are normal. To minimize them, trim excess fat off meat before grilling.
	Grill grate is not positioned correctly; grease runs down into the radiant tray rather than the grease drip-pan	Turn the grill off, wait for it to cool, then position it correctly. See 'Using the grill' for instructions and illustrations.
There is a power failure - can I still use the grill?	Power outage in your home or neighborhood	The grill cannot be used until power is restored.
The grill will not light; halo does not illuminate when the knob is turned	The oven is in a CLEAN cycle	Wait until the CLEAN cycle has finished, or follow the instructions under 'To cancel a CLEAN cycle in the section 'Care and cleaning'.
CLEAN CYCLE - 48" MODELS ONLY		
The oven mode and temperature knob halos on the secondary oven flash white	A CLEAN cycle is already running in the main oven	Wait until the CLEAN cycle has finished, or follow the instructions under 'To cancel a CLEAN cycle in the section 'Care and cleaning'.
The oven mode and temperature knob halos on the main oven flash red	The secondary oven is already in use	A CLEAN cycle cannot run when the secondary oven is in use. Turn the temperature and oven mode knobs of the secondary oven to OFF.

ALERTS

ALERT	POSSIBLE CAUSES	WHAT TO DO
The OVEN MODE knob is flashing orange	Electronics fault	Disconnect and reconnect the oven to the power supply. If the fault persists contact your Authorized Service Center or Customer Care.
The TEMPERATURE knob is flashing orange	Electronics fault	Disconnect and reconnect the oven to the power supply. If the fault persists contact your Authorized Service Center or Customer Care.
The OVEN MODE knob is flashing white	Technical fault	Contact your Authorized Service Center or Customer Care.

WARRANTY AND SERVICE

Before you call for service or assistance ...

Check the things you can do yourself. Refer to the installation instructions and your user guide and check that:

- ① Your product is correctly installed.
- ② You are familiar with its normal operation.

If after checking these points you still need assistance or parts, refer to the Service & Warranty book for warranty details and your nearest Authorized Service Centre, Customer Care, or contact us through our website www.fisherpaykel.com.

Contact details

For replacement parts or if further help is needed concerning this appliance call:

Toll Free 1 888 9 FNP USA (1 888 936 7872)

or write to:

Fisher & Paykel Appliances Inc.
695 Town Center Drive
Suite 180 Costa Mesa
CA 92626-1902
USA

or contact us through our web site www.fisherpaykel.com

Complete and keep for safe reference:

Model _____
Serial No. _____
Purchase Date _____
Purchaser _____
Dealer _____
Suburb _____
Town _____
Country _____

FISHERPAYKEL.COM

© Fisher & Paykel Appliances 2018. All rights reserved.

The product specifications in this booklet apply to the specific products and models described at the date of issue. Under our policy of continuous product improvement, these specifications may change at any time. You should therefore check with your Dealer to ensure this booklet correctly describes the product currently available.

US CA

591088D 05.18