

5" Series 11 Modular Auxiliary Downdraft Rangehood

Minimal

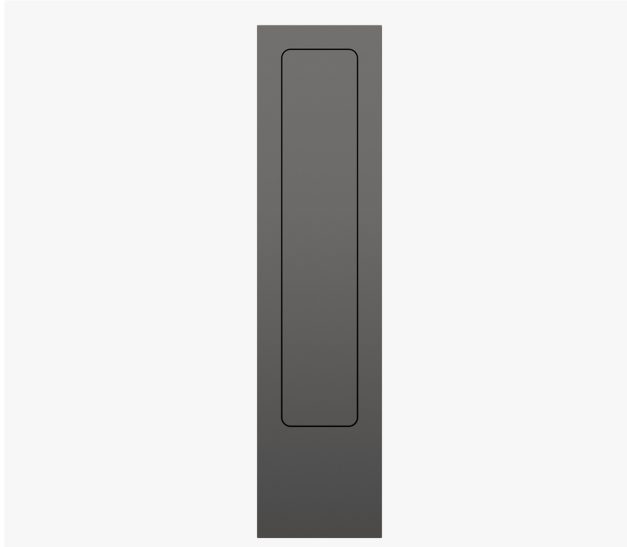

DIMENSIONS

Height	7 3/8 "
Width	5 1/8 "
Depth	20 7/8 "

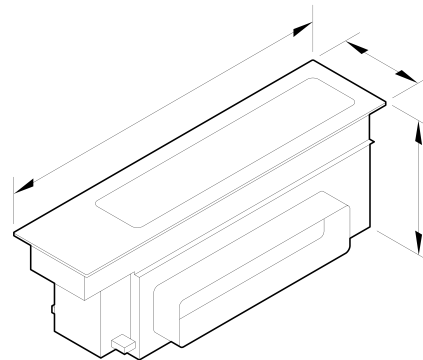

SPECIFICATIONS

Fan ratings

Maximum air movement	330 CFM
Maximum speed sound rating	9 sones

Installation and cleaning

Air outlet size	3.25" x 12" (Included), 2.25" x 12" (Optional) "
-----------------	---

Dishwasher safe filters	1
-------------------------	---

Performance

Extraction type	Surface
Fan speeds	5 + Boost
Filter type	Mesh with Stainless Steel filter cover
Number of filters	1

Power Requirements

Connection	Flex cord, 3-pin plug
Service	5 A
Supply frequency	60 Hz
Supply voltage	120 V

Product Dimensions

Depth	20 7/8 "
Height	7 3/8 "
Width	5 1/8 "

Ventilation features

Auto-off/Run-on timer	•
Bluetooth connectivity	•
Timer function	•

With powerful extraction, this ventilation module fits seamlessly into your countertop. Designed to pair with a Primary Modular Induction Cooktop for the ultimate culinary solution.

- Part of our unique modular cooking solution. Pair with a primary cooktop for a unified cooking experience
- Seamless kitchen integration, without the need for overhead ventilation
- Links to adjacent cooktop modules, with automatic extraction at the right speed to suit your cooking
- With five fan speeds and a boost function for effective removal of odors and steam

SKU

82847



A PEACE OF MIND SALE
24 Hours 7 Days a Week Customer Support
T 1.888.936.7872 W www.fisherpaykel.com

The product dimensions and specifications in this page apply to the specific product and model. Under our policy of continuous improvement, these dimensions and specifications may change at any time. You should therefore check with Fisher & Paykel's Customer Care Centre to ensure this page correctly describes the model currently available. © Fisher & Paykel Appliances Ltd 2020

Other product downloads available at fisherpaykel.com

- [↓](#) Planning Guide (English)
- [↓](#) Planning Guide (Canadian French)
- [↓](#) Planning Guide (Spanish)
- [↓](#) California Warning Proposition 65 (English, Spanish, Canadian French, Chinese)

Where applicable:

All appliances use energy, and energy usage typically generates carbon emissions. **Fisher & Paykel Appliances' In-use Energy Carbon Emissions Estimate** indicates carbon emissions from a product's in-use energy. This is calculated either annually or per cycle, using the product's market-specific energy label energy consumption data multiplied by the carbon emissions factor for energy in your country or region.

Our In-use Energy Carbon Emissions Estimate is designed to assist customers in making informed purchasing decisions when comparing different Fisher & Paykel products. For example, a heat pump dryer typically has a lower In-use Energy Carbon Emissions Estimate than a vented dryer.