

Top Loader Washing Machine, 7.5kg

Series 7 | Top Load

White



Running on SmartDrive™ technology for a quicker, quieter wash, you'll have plenty of room for a generous wash load.

- Six wash cycles including Quick, Wool and Delicate
- Energy saving with Eco-Active™
- 4 star energy and 3.5 star water rating

DIMENSIONS

Height	1045mm
Width	600mm
Depth	600mm

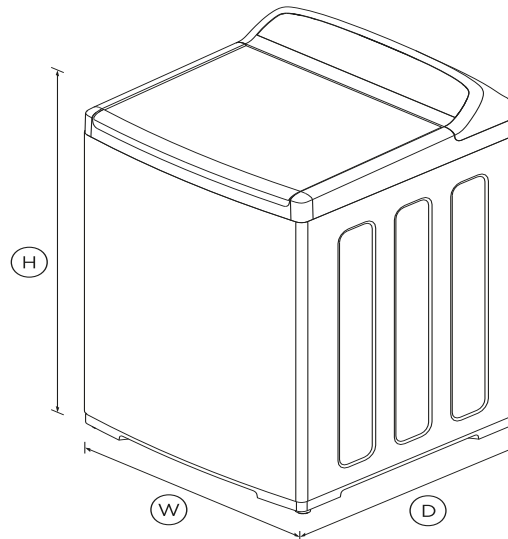

FEATURES & BENEFITS

Easy to use

This machine has a cycle to suit every type of load including Delicate, Allergy and Wool. Select a cycle with easy-to-use SmartTouch™ controls.

Easy Installation

Self-levelling feet make installation easy and ensure the washer stays level, to reduce vibration and keep noise to a minimum.

Eco-Active™ Wash

Eco-Active™ recirculates water and detergent through clothes so less hot water is used to remove stains, dirt and bacteria.

Cares for clothes

The flexible finned agitator ensures less tangling for superior clothes care.

Quicker drying

Drying times are reduced due to a fast spin speed of 1100RPM, which helps remove more water.

Soft-Close Lid

The robust plastic lid has a soft close mechanism that makes it family safe, avoids slamming and allows for hands-free operation.

SPECIFICATIONS

Consumption

Energy rating	4 star
Energy usage	289kWh/year
In-use energy carbon	39.1kgCO2e/year
Water consumption per cycle	92L
Water efficiency	3.5 star (WELS)

Features

Adjustable alert beeps	•
Agitator	Flexible finned
Auto out of balance correction	•
Automatic water level	•
Child/Keylock	•
Controlled cold	•
Delay start	•
Detergent dispenser	•
Eco rinse	•

Fabric softener dispenser	•
Lid lock	•
Manual water levels	5
No spin / Spin Hold	•
Rinse options	3
Spin speeds	3
Stainless steel drum	•
Water temperature controls	5

Eco-Active™	•
Heavy	•
Number of wash cycles	6
Quick	•
Regular	•
Wool	•

SKU 92262

The product dimensions and specifications in this page apply to the specific product and model. Under our policy of continuous improvement, these dimensions and specifications may change at any time. You should therefore check with Fisher & Paykel's Customer Care Centre to ensure this page correctly describes the model currently available. ? Fisher & Paykel Appliances Ltd 2020

Performance

Auto-Lint disposal	•
Detergent	Regular
Load sensing	•
Maximum spin speed	1100rpm
Number of spin speeds	3
SmartDrive™ technology	•

Product dimensions

Depth	600mm
Height	1045mm
Height (Lid open)	1350 - 1380mm
Width	600mm

Warranty

Parts and labour	2 years
Parts only SmartDrive™ Motor	10 years

Wash Cycles

Allergy	•
Delicate	•

Other product downloads available at fisherpaykel.com

- [↓](#) User Guide
- [↓](#) Service & Warranty
- [↓](#) Energy & Water Label
- [↓](#) Installation Guide



A PEACE OF MIND SALE

24 Hours 7 Days a Week Customer Support

T 0800 372 273 W www.fisherpaykel.com