

30" Series 9 Professional 4 Zone Induction Self-Cleaning Range, with SmartZone

Professional



With intuitive touchscreen, induction cooktop and a convection oven with 15 functions, cooking on this refined range is a joy.

- Guided cooking using your touchscreen makes it simple to cook by food, function or recipe.
- Ability to pair two of the four induction cook zones to create a large SmartZone
- 4 cu ft total oven capacity
- Beautiful LED halo-illuminated dials provide information at a glance

DIMENSIONS

Height	35 3/4 - 36 3/4 "
Width	29 7/8 "
Depth	29 1/8 "

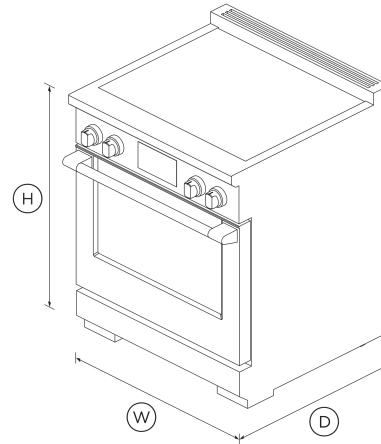

FEATURES & BENEFITS

Cook With Confidence

Our touchscreen interface provides an intuitive guided cooking experience that helps deliver perfect results, whether you've been cooking all your life or just starting out. Cook with a favorite method, a hero ingredient, or a go-to cooking function or recipe. The screen tilts for improved ergonomics and optimal visibility while cooking.

Generous Capacity

Featuring a generous total capacity of 4 cu ft, with enough room to fit a 26 lb turkey, or to cook several dishes at once.

Cooktop Power

Instant and immediate control from the highest to the gentlest heat. The finely tuned cooktop controls let you sear, stir fry or simmer to perfection. Since most of the heat generated by the cooktop is transferred into cookware, induction offers an energy-efficient cooking option.

Cooking Flexibility

No matter what you're cooking, you've got the right heat to get perfect results. Each of the 15 oven functions have been extensively researched and carefully designed to cater to a broad range of dishes and cooking styles. The handy food probe helps you monitor your progress.

Design Quality

This range has craftsmanship in every detail, with real stainless steel, high-quality glass, and beautifully weighted, halo illuminated dials. Each cavity features incandescent lights and full extension telescopic racks. From the robust legs to the powerful cooktop, this Range is built to last.

Easy To Clean

The oven features a self-cleaning function and self-clean proof side racks, which don't need to be removed when using this function. The durable induction cooktop surface only needs a quick wipe after use to keep it clean.

SPECIFICATIONS

Accessories (included)

- Adjustable feet covers
- Branded coin end cap

Accessories (sold separately)

Wok grate included **No**

Capacity

Shelf positions **5**
 Total capacity **4 cu ft**
 Usable capacity **3.3 cu ft**

Cleaning

Pyrolytic self-clean **•**

Consumption

Energy usage **490kWh/year**
 In-use energy carbon emissions estimate **56.5kgCO2e/year**

Controls

Electric circuit **4**
 High resolution display **•**
 Metal illuminated dials **•**
 Multi-language interface **•**
 Recipe and food based functions **•**
 Sabbath mode **•**
 Smart appliance **•**
 Tilting touch screen interface **•**

Main oven functions

Warm **•**

Oven features

Broil pan **•**
 Concealed element **•**
 Electronic oven control **•**
 Food probe **•**
 Full extension telescopic sliding shelves **•**
 Self-clean proof side racks **•**
 True convection **•**

Oven functions

Air fry **•**
 Bake **•**
 Classic bake **•**
 Clean **•**
 Convection bake **•**
 Convection Broil **•**
 Dehydrate **•**
 Maxi Broil **•**
 Number of functions **15**
 Pastry bake **•**
 Pizza bake **•**
 Rapid proof **•**
 Roast **•**
 Slow cook **•**
 True convection **•**
 Warm **•**

Oven performance

Bake power **3500**
 Main oven - True convection power **2500 W**

Power requirements

Connection **4-prong grounding type [NEMA 14-50P plug]**
 Service **50 A**
 Supply frequency **60 Hz**
 Supply voltage **208 - 240 V**

Product dimensions

Depth **29 1/8 "**
 Height **35 3/4 - 36 3/4 "**
 Width **29 7/8 "**

Rangetop features

Gentle heat **•**
 Heat settings **9**
 Induction cooking technology **•**
 SmartZone **1**
 Zone bridging **•**

Rangetop Performance

Left front zone rating **1400 (2200) W**
 Left rear zone rating **2600 (3700) W**

Number of cooking zones	4
PowerBoost	•
Right front zone rating	2100 (3700) W
Right rear zone rating	2100 (3700) W

The product dimensions and specifications in this page apply to the specific product and model. Under our policy of continuous improvement, these dimensions and specifications may change at any time. You should therefore check with Fisher & Paykel's Customer Care Centre to ensure this page correctly describes the model currently available. © Fisher & Paykel Appliances Ltd 2020

Our In-use Energy Carbon Emissions Estimate is designed to assist customers in making informed purchasing decisions when comparing different Fisher & Paykel products. For example, a heat pump dryer typically has a lower In-use Energy Carbon Emissions Estimate than a vented dryer.

Recommended Back Guards Ventilation

Combustible situation	BGRV3-3030H
Non combustible situation	BGRV2-3030 / BGRV2-1230
Recommended hood	HCB30-6_N (Professional Range Hood)

Other product downloads available at fisherpaykel.com

- [↓](#) DWG
- [↓](#) DWG
- [↓](#) DWG
- [↓](#) DXF
- [↓](#) DXF
- [↓](#) DXF
- [↓](#) Archicad
- [↓](#) Installation Guide (English)
- [↓](#) Installation Guide (Canadian French)
- [↓](#) Planning Guide - 30" Professional Ranges & Backguards (English)
- [↓](#) Revit
- [↓](#) Rhino
- [↓](#) Right To Repair Declaration (English, Canadian French)
- [↓](#) SketchUp
- [↓](#) User Guide (English)
- [↓](#) User Guide (Canadian French)

Safety

ADA compliant	•
Pan detection system	•
Safety time out	•
Surface hot indicators	•

Secondary oven features

Food probe	•
------------	---

Where applicable:

All appliances use energy, and energy usage typically generates carbon emissions. **Fisher & Paykel Appliances' In-use Energy Carbon Emissions Estimate** indicates carbon emissions from a product's in-use energy. This is calculated either annually or per cycle, using the product's market-specific energy label energy consumption data multiplied by the carbon emissions factor for energy in your country or region.



A PEACE OF MIND SALE
 24 Hours 7 Days a Week Customer Support
 T 1.888.936.7872 W www.fisherpaykel.com

SKU	82794
-----	-------