

48" Series 9 Wall Range Hood

Width	47 7/8 "
Depth	25 1/16 "

Our Range Hood filters have been improved to capture more cooking steam, odors and grease. They're easy to remove and clean - simply put them in your DishDrawer™ dishwasher.

Professional

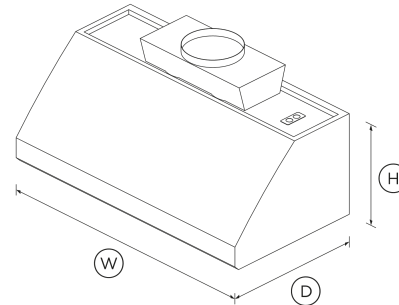

Your Kitchen, Your Style

Enhance your culinary experience in the kitchen with our Range Hood accessories from heat lamps through to duct covers. Choose a range hood to fit your kitchen - there are three different sizes.

SPECIFICATIONS

Accessories (sold separately)

12" Vertical duct cover	HCC4812
6" Vertical duct cover	HCC4806
Infrared warming lights	HIR48
Light bulb	104176P

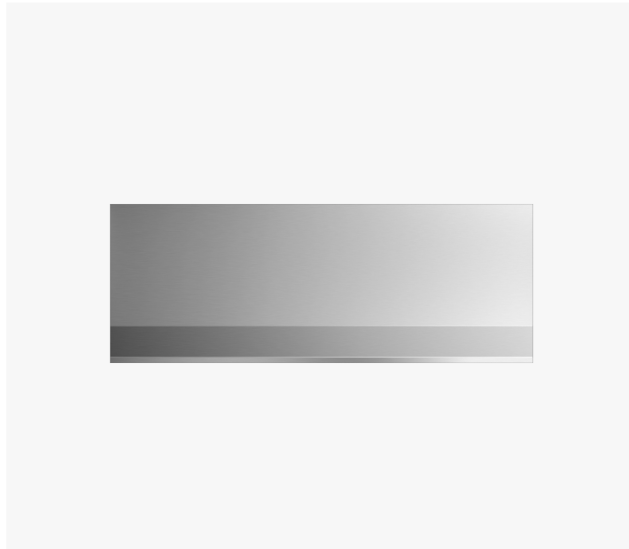

FEATURES & BENEFITS

Simple Design

The new stainless steel range hood is tough and hardworking with a style and simplicity to fit seamlessly into your kitchen.

Edge To Edge Filters

We've improved our filters to capture and extract more cooking steam, odors and grease.

Precise Control

The Professional Range Hood has been designed to give you better control with sturdy stainless steel dials to set your desired fan speed and light level.

Effective Extraction

Fan ratings

Maximum speed sound rating	13 sones
Speed 1 sound rating	2.5 sones

Installation and cleaning

Air outlet size	2 x 8" "
Dishwasher safe filters	3
Ducted	Top extraction
Metal transition to ductwork	Optional - Transition HTRN10
Recirculation	Ducted only

Performance

Striking design that pairs well with any appliances in our Professional range. With powerful extraction of steam and odors.

- With four fan speeds, select the perfect extraction rate for your cooking
- Dishwasher-safe filters that are easy to remove and clean
- Powerful 1200CFM maximum airflow

DIMENSIONS

Height	18 "
---------------	-------------

Extraction type	Surface
Fan speeds	4
Filter type	Stainless Steel Baffle

Power Requirements

Lighting power	50 W
Motor power	910 W
Supply voltage	120 V
Total Power	1060 W

Product Dimensions

Depth	25 1/16 "
Height	18 "
Width	47 7/8 "

Ventilation features

Dimmable lights	•
Light type	Halogen

SKU	50257
-----	-------

The product dimensions and specifications in this page apply to the specific product and model. Under our policy of continuous improvement, these dimensions and specifications may change at any time. You should therefore check with Fisher & Paykel's Customer Care Centre to ensure this page correctly describes the model currently available. © Fisher & Paykel Appliances Ltd 2020

Other product downloads available at fisherpaykel.com

- [↓ Archicad](#)
- [↓ Archicad - 12" Duct Cover](#)
- [↓ Archicad - 6" Duct Cover](#)
- [↓ Revit](#)
- [↓ Rhino](#)
- [↓ Rhino - Duct Cover Transition](#)
- [↓ Right To Repair Declaration \(English, Canadian French\)](#)
- [↓ SketchUp](#)
- [↓ SketchUp - Duct Cover Transition](#)
- [↓ Installation & User Guide \(English, Canadian French\)](#)

Where applicable:

All appliances use energy, and energy usage typically generates carbon emissions. **Fisher & Paykel Appliances' In-use Energy Carbon Emissions Estimate** indicates carbon emissions from a product's in-use energy. This is calculated either annually or per cycle, using the product's market-specific energy label energy consumption data multiplied by the carbon emissions factor for energy in your country or region.

Our In-use Energy Carbon Emissions Estimate is designed to assist customers in making informed purchasing decisions when comparing different Fisher & Paykel products. For example, a heat pump dryer typically has a lower In-use Energy Carbon Emissions Estimate than a vented dryer.



A PEACE OF MIND SALE
 24 Hours 7 Days a Week Customer Support
 T 1.888.936.7872 W www.fisherpaykel.com