

FISHER & PAYKEL

DATA SHEET Built-in Coffee Maker, 60cm

Model no:
EB60DSX1

Product Dimensions	mm
Ⓐ Overall height of product	458
Ⓑ Overall width of product	596
Ⓒ Overall depth of product (excludes front metal trim)	480
Ⓓ Height of chassis	445
Ⓔ Width of chassis	560
Ⓕ Depth of chassis	460
Ⓖ Depth of coffee maker front frame and control panel (excludes front metal trim)	20
Ⓗ Height of control panel	100
Ⓘ Height of metal cap on control panel	20
Ⓚ Height of horizontal lower section from bottom datum	83
Ⓛ Stepdown from control panel to chassis	13
Ⓜ Extent coffee maker pulls out	435

Minimum Clearances	mm
Minimum inside height of cavity (proud installation)	450
Minimum inside width of cavity	560
Minimum inside depth of cavity from front datum	545
Overall height of cabinetry	460
Overall width of cabinetry	600
Rear ventilation air vent depth*	50
Rear ventilation air vent width*	560

*A rear ventilation air vent totalling 280cm² is required. The air vent must be located at the rear of cabinet. It can be positioned at the base, sides, back or top of the cavity.

IMPORTANT NOTE: For full installation and clearance details please refer to our installation manual.

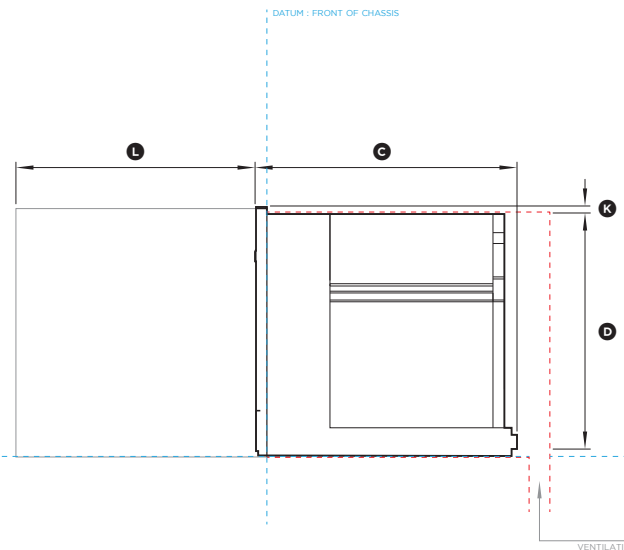
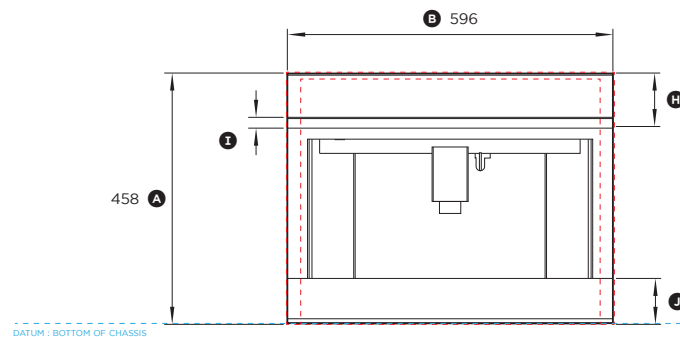
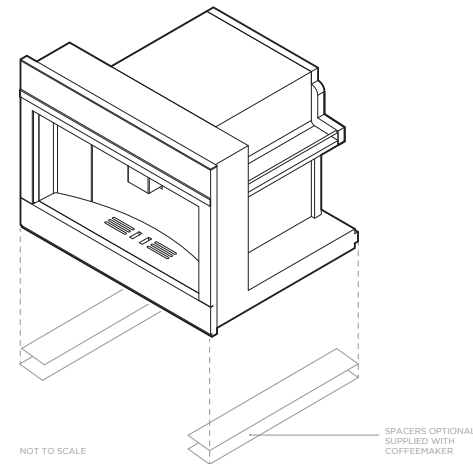
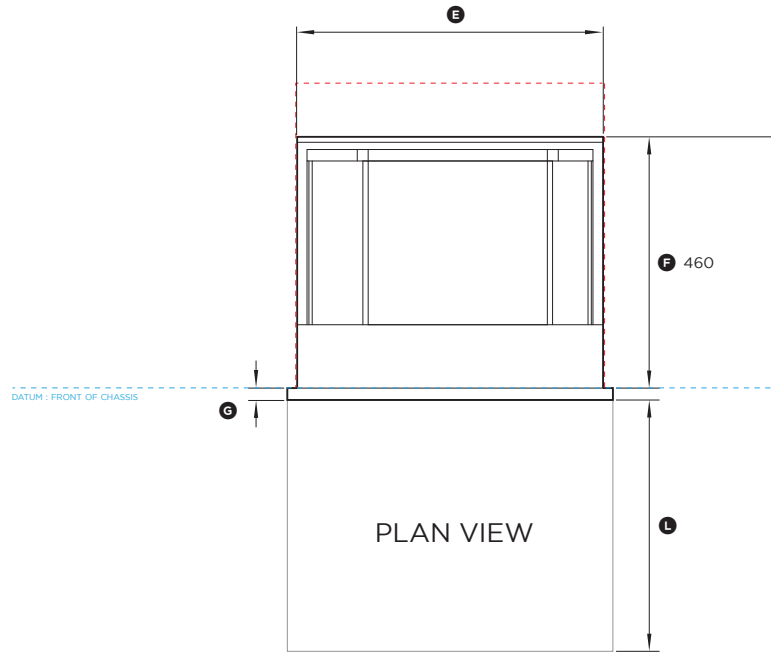

INDICATES CABINETRY / PRODUCT DATUM -----
INDICATES CABINETRY CLEARANCES -----

DATE: 05.12.2022

90002981A

IMPORTANT NOTE: Throughout this guide, dimensions may vary by $\pm 2\text{mm}$ (1/16"). Please read the installation manual for detailed information on installing the product. For full installation instructions & specifications visit fisherpaykel.com

