

# 60cm Series 9 Minimal Compact Combi-Steam Oven

Series 9 | Minimal



Reduce the need for oils and fats with steam cooking, paired with convection oven functions for cooking flexibility.

- 36L total capacity
- Cooking flexibility with nine oven functions, including five Steam functions, Grill and Fan Forced
- Steam cooking allows you to cook a food in its own juices, to retain nutrients and flavour
- Designed to match aesthetically with companion products such as warming drawers, for flexible cooking configurations

## DIMENSIONS

Height	458 mm
Width	596 mm
Depth	562 mm

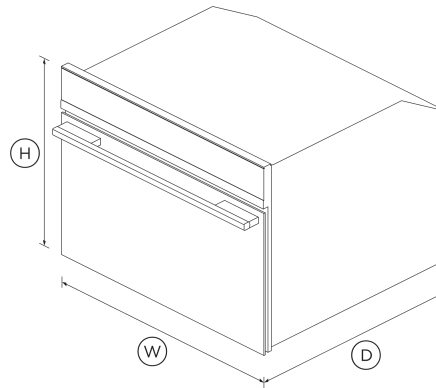

## FEATURES & BENEFITS

### Sized To Suit

The compact 46cm height means this Combination Steam Oven can be placed almost anywhere. companion products share the same dimensions and can be installed in multiple configurations to suit your kitchen design and preference.

### Cooking Flexibility

The Combination Steam Oven allows ingredients to retain their nutrients, moisture content and colouration. With nine oven modes, it doesn't just Steam, but also has Grill and Fan functions.

### Easy To Use

An easy to use, intuitive display shows the time and provides useful information about functions along with a refill alert.

### Beauty Of Choice

With the choice of a stylish stainless steel or elegant black trim, our companion products help you achieve a coherent kitchen aesthetic that suits your design style.

### Easy Cleaning

Cleaning and care of the Combination Steam Oven is easy. Simply wipe the smooth stainless steel interior with a dry cloth after each use.

### Safe And Sound

The CoolTouch door is safe to touch from the outside, protecting your hands and the surrounding cabinetry.

## SPECIFICATIONS

### Accessories (included)

Baking pan	1
Perforated large steam dish	1
Wire shelf	1
Wired temperature sensor	1

### Accessories (sold separately)

Optional 76cm/30" trim kit	Part 81940
----------------------------	------------

### Capacity

Shelf positions	3
Total capacity	36 L
Usable capacity	29 L

**Cleaning**

- Easy clean stainless steel interior
- Removable water tank
- Steam clean (oven)

Steam clean (oven) •

**Performance**

Grill power **1500 W**  
 SteamTechnology •

**Controls**

- Adjustable audio and display settings
- Automatic cooking/minute timer
- Automatic pre-set temperatures
- Celsius/Fahrenheit temperature
- Delay start
- Electronic capacitive touch controls
- Electronic clock
- Electronic oven control
- Food probe
- Guided cooking by food type and recipes
- Internal Light
- Intuitive touchscreen display

**Power requirements**

Amperage **15 A**  
 Supply frequency **50 Hz**  
 Supply voltage **220 - 240 V**

**Product dimensions**

Depth **562 mm**  
 Height **458 mm**  
 Width **596 mm**

**Safety**

- Control panel key lock
- CoolTouch door
- Safety thermostat

**Functions**

- Fan forced
- Fan grill
- Grill
- Number of functions **9**
- Ring + grill
- Steam + ring
- Steam 100 (100°C / 210°F)
- Steam 130 (130°C / 265°F)
- Steam assist

SKU **81924**

The product dimensions and specifications in this page apply to the specific product and model. Under our policy of continuous improvement, these dimensions and specifications may change at any time. You should therefore check with Fisher & Paykel's Customer Care Centre to ensure this page correctly describes the model currently available. © Fisher & Paykel Appliances Ltd 2020

**Other product downloads available at fisherpaykel.com**

- [↓](#) 2D-DWG Combination Steam Oven
- [↓](#) 2D-DXF Combination Steam Oven
- [↓](#) Archicad
- [↓](#) Archicad Appliance with Bottom Trim
- [↓](#) Archicad Appliance with 760mm Trim
- [↓](#) Data Sheet Combination Steam Oven
- [↓](#) Installation Guide
- [↓](#) Revit
- [↓](#) Revit Appliance with Bottom Trim
- [↓](#) Revit Appliance with 760mm Trim
- [↓](#) Rhino
- [↓](#) Rhino Appliance with Bottom Trim
- [↓](#) Rhino Appliance with 760mm Trim
- [↓](#) SketchUp
- [↓](#) SketchUp Appliance with Bottom Trim
- [↓](#) SketchUp Appliance with 760mm Trim
- [↓](#) User Guide

**Where applicable:**

All appliances use energy, and energy usage typically generates carbon emissions. **Fisher & Paykel Appliances' In-use Energy Carbon Emissions Estimate** indicates carbon emissions from a product's in-use energy. This is calculated either annually or per cycle, using the product's market-specific energy label energy consumption data multiplied by the carbon emissions factor for energy in your country or region.

Our In-use Energy Carbon Emissions Estimate is designed to assist customers in making informed purchasing decisions when comparing different Fisher & Paykel products. For example, a heat pump dryer typically has a lower In-use Energy Carbon Emissions Estimate than a vented dryer.



**A PEACE OF MIND SALE**  
**24 Hours 7 Days a Week Customer Support**  
T 1300 650 590 W [www.fisherpaykel.com](http://www.fisherpaykel.com)