

Single DishDrawer™ Dishwasher, Tall, Sanitise

Series 9 | Contemporary

Black Stainless Steel



Created with extra height for large dishes and designed to be placed anywhere in your kitchen, for loading dishes with minimal bending.

- Designed to be installed under your benchtop, with a recessed handle for a seamless look
- Six wash programs, as well as additional Quick wash, Sanitise and Extra Dry modifiers
- With extra height for taller dishes, and customisable internal shelving

- Wi-Fi enabled and works with the SmartHQ™ app for remote control and notifications

DIMENSIONS

Height	454mm
Width	599mm
Depth	573mm

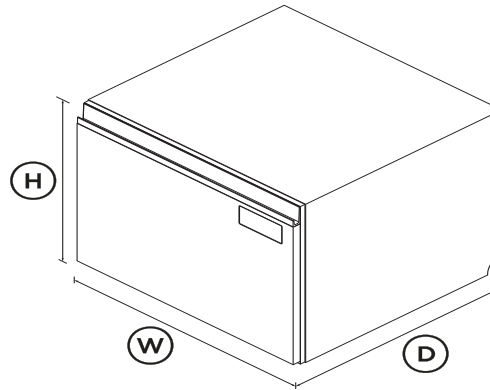

FEATURES & BENEFITS

Seamless Fit

Our built-under DishDrawer™ Dishwashers are installed flush under your benchtop, and are designed to match our Contemporary style family of appliances for a seamless kitchen finish.

Designed For Real Life

Designed to make everyday life simpler, DishDrawer™ Dishwashers can be distributed throughout the kitchen to support patterns of use. As easy to open and close as kitchen drawers, they can be conveniently positioned at bench height for ease of loading and minimal bending.

Easy to load

Designed to fit six place settings, with foldable racking to fit taller dishes up to 310mm. Flexible racking allows you to make adjustments to fit in a variety of dishes.

Quick, Sanitise and Extra Dry options

The Quick wash modifier delivers a faster wash while maintaining performance. The Sanitise option provides extra protection, killing 99.9% of bacteria* in the final rinse. The Extra Dry setting is perfect for plastic dishes. *Certified to NSF/ANSI Standard 184

Quiet Performer

Running at a very low decibel rating, these DishDrawer™ Dishwashers do their job without making a fuss. The combination of intelligent technology and simple mechanics means greater reliability and excellent wash performance.

Beauty Of Choice

As much a design component as a high performance appliance, the black DishDrawer™ Dishwasher brings a touch of sophistication to your kitchen, on its own or part of a matching kitchen appliance set.

SPECIFICATIONS

Accessories

- Cutlery basket
- Knife clip and multipurpose

Capacity and loading

- Accommodates round plates **310mm**
- Adjustable height, foldable

- Fold down tines
- Pitch adjustable tines

Amperage	5A
Supply frequency	50Hz
Supply voltage	220 - 240V

SKU 82898

Consumption

Energy rating	F
Energy usage	61kWh/100 cycles
In-use energy carbon	18.8kgCO2e/100 cycles
Water usage (per wash cycle)	7.9L

Product dimensions

Depth	573mm
Height	454mm
Width	599mm

The product dimensions and specifications in this page apply to the specific product and model. Under our policy of continuous improvement, these dimensions and specifications may change at any time. You should therefore check with Fisher & Paykel's Customer Care Centre to ensure this page correctly describes the model currently available. Fisher & Paykel Appliances Ltd 2020

Controls

- Energy saving delay start
- Internal wash selector
- Keylock
- Knock to pause
- Rinse aid indicator light
- Wi-Fi connectivity

Warranty

Parts and labour	5 years
------------------	---------

Where applicable:

All appliances use energy, and energy usage typically generates carbon emissions. **Fisher & Paykel Appliances' In-use Energy Carbon Emissions Estimate** indicates carbon emissions from a product's in-use energy. This is calculated either annually or per cycle, using the product's market-specific energy label energy consumption data multiplied by the carbon emissions factor for energy in your country or region.

Our In-use Energy Carbon Emissions Estimate is designed to assist customers in making informed purchasing decisions when comparing different Fisher & Paykel products. For example, a heat pump dryer typically has a lower In-use Energy Carbon Emissions Estimate than a vented dryer.

Features

- Built-in water softener
- Fan assisted drying
- Flood protection
- Flow through detergent
- Motor type BLDC
- Quiet operation
- SmartDrive™ technology

Wash Program Modifiers

- Extra Dry
- Quick
- Sanitise
- Wash modifiers 3

Wash Programs

- Delicate
- Eco
- Fast
- Heavy
- Medium
- Rinse
- Wash programs 6

Performance

Noise emissions	42dBA
-----------------	-------

Water connection

Water pressure	100kPa - 1000kPa
Water supply	3/4" BSP (20mm) Connector

Power requirements

Other product downloads available at fisherpaykel.com



Service & Warranty



User Guide DishDrawer™ Dishwasher



Declaration of Conformity Single DishDrawer™ Dishwasher



Installation Guide Single DishDrawer™ Dishwasher



Preliminary Specification Guide Single DishDrawer™ Dishwasher



A PEACE OF MIND SALE

24 Hours 7 Days a Week Customer Support

T 1800 625174 W www.fisherpaykel.com