

60cm Series 7 Minimal Pyrolytic Oven

Height	598 mm
Width	596 mm
Depth	565 mm

Shelf positions	6
Total capacity	85 L
Usable capacity	72 L

Minimal

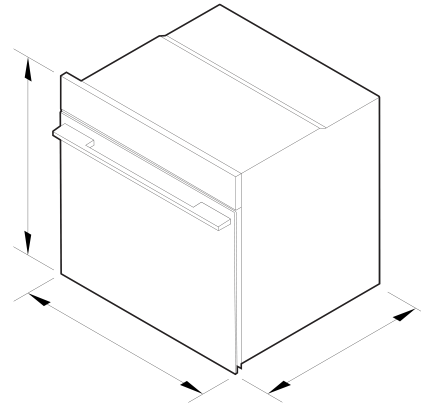

SPECIFICATIONS

Accessories (included)

Flat brushed baking tray	1
Multi-functional Air fry tray	1
Pyrolytic proof shelf runners	•
Roasting dish	1
Telescopic sliding runners	1 set
Wire shelf	2
Wired temperature sensor	1

Capacity

Cleaning

- Acid resistant graphite enamel
- Pyrolytic self-clean
- Pyrolytic-proof side ladders
- Removable oven door
- Removable oven door inner glass
- Removable side ladders

Connected Features

- Alerts and notifications
- Education and onboarding
- Monitoring
- Remote operation
- Software updates

Controls

- Adjustable audio and display settings
- Audio feedback
- Automatic cooking/minute timer
- Automatic pre-set temperatures
- Celsius/Fahrenheit temperature
- Delay start
- Electronic oven control
- Guided touchscreen cooking

This refined and minimal oven with pyrolytic cleaning features a 5" touchscreen and method-led cooking for perfect results.

- Create perfect results with precise cooking methods, including Air Fry and Slow Cook, via the 5" touchscreen
- Pyrolytic self-cleaning breaks down food residue for simple maintenance
- Generous 85L total capacity

DIMENSIONS

Interface type	5" touchscreen
Internal Light	•
Intuitive touchscreen display	•
Multi-language display	true
Smart appliance	•
Soft close doors	•
Wireless temperature sensor compatible	•

AeroTech™ technology	•
Automatic rapid pre-heat	•
Grill power	3000 W
Method Cooking	•
Temperature range	35°C - 280°C

The product dimensions and specifications in this page apply to the specific product and model. Under our policy of continuous improvement, these dimensions and specifications may change at any time. You should therefore check with Fisher & Paykel's Customer Care Centre to ensure this page correctly describes the model currently available. © Fisher & Paykel Appliances Ltd 2020

Functions

Air fry	•
Bake	•
Classic bake	•
Classic fan	•
Dehydrate	•
Eco slow cook	•
Fan bake	•
Fan forced	•
Fan grill	•
Grill	•
Number of functions	16
Pyrolytic self-clean	•
Rapid proof	•
Roast	•
Slow cook	•
Vent bake	•
Warm	•

Power requirements

Connection type	Flex cord
Dedicated circuit	16 A
Power cord length	1.5m
Rated power	2800-3300 W
Supply frequency	50 Hz
Supply voltage	220-240 V

Product dimensions

Depth	565 mm
Height	598 mm
Width	596 mm

Safety

Control panel key lock	•
------------------------	---

SKU	85901
-----	-------

Other product downloads available at fisherpaykel.com

- [↓](#) DWG
- [↓](#) DXF
- [↓](#) First Use (Chinese)
- [↓](#) First Use (English)
- [↓](#) Installation Considerations (English, Chinese)
- [↓](#) Planning Guide - 60cm Series 7 Minimal (English)
- [↓](#) Revit
- [↓](#) Rhino
- [↓](#) Restriction of the Use of Hazardous Substances (Chinese)
- [↓](#) Sketchup

Where applicable:

All appliances use energy, and energy usage typically generates carbon emissions. **Fisher & Paykel Appliances' In-use Energy Carbon Emissions Estimate** indicates carbon emissions from a product's in-use energy. This is calculated either annually or per cycle, using the product's market-specific energy label energy consumption data multiplied by the carbon emissions factor for energy in your country or region.

Our In-use Energy Carbon Emissions Estimate is designed to assist customers in making informed purchasing decisions when comparing different Fisher & Paykel products. For example, a heat pump dryer typically has a lower In-use Energy Carbon Emissions Estimate than a vented dryer.

Performance

ActiveVent™ system	•
--------------------	---