

Series 9, Professional Tall Double DishDrawer Dishwasher

Professional



Part of our Professional series, with stainless steel styling and room for your larger dinner plates and dishes.

- Six wash programs, as well as additional Quick wash, Sanitize and Extra Dry options
- Flexible racking can be folded down to fit bigger dishes

DIMENSIONS

Height 34 - 36 3/8 "

Width 23 9/16 "
Depth 22 9/16 "

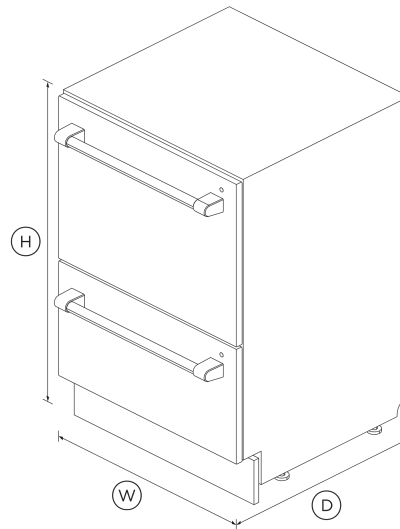

FEATURES & BENEFITS

Ease Of Use

DishDrawer™ Dishwashers are as easy to open and close as kitchen drawers and can be conveniently positioned at bench height for ease of loading and minimal bending. Flexible racking allows you to make adjustments to fit in a variety of dishes.

INDEPENDENT WASH

With the ability to use both drawers independently and select different wash programs the DishDrawer™ Dishwasher can wash everything from fine glass and crystal to heavily soiled pots and pans.

True half load

Each drawer holds a true half load for guilt-free small washes and fast turnaround of your dishes. Both drawers operate independently so different wash cycles can operate simultaneously to accommodate a variety of loads.

Complementary design

DishDrawer™ Dishwashers are designed to match the Fisher & Paykel family of kitchen appliances, with matching handles, premium styling and quality materials for a stylish finish in your kitchen.

Quick, Sanitize and Extra Dry options

The Quick wash modifier delivers a faster wash while maintaining performance. The Sanitize option provides extra protection killing 99.9% of bacteria in the final rinse. The Extra Dry setting is perfect for plastic dishes.

Quiet performer

Running at a very low decibel rating, these DishDrawer™ dishwashers do their job without making a fuss. The combination of intelligent technology and simple mechanics means greater reliability and excellent wash performance.

SPECIFICATIONS

Accessories (included)

- Cutlery basket
- Kickstrip **true**
- Knife clip and multipurpose clip

Capacity and loading

- Accommodates round plates up to **12.25" (top)**
11" (bottom)
- Adjustable height, foldable cupracks
- Fold down tines

Pitch adjustable tines	•
Place settings	14
Place settings	14
Place settings per drawer	7

Connected Features

Alerts and notifications	•
Education and onboarding	•
Monitoring	•
Software updates	•

Consumption

Energy usage	263kWh/year
In-use energy carbon emissions estimate	92.8kgCO2e/year
Water usage (per wash cycle)	3.28 gal running both tubs

Controls

Electronic fault/Diagnostic indicator	•
End of cycle beeps	•
Energy saving delay start option of up to 12 hours	•
Internal wash selector	•
Keylock	•
One button start	•
Rinse aid indicator light	•
Smart appliance	•

Features

Fan assisted drying	•
Flood protection	•
Flow through detergent dispenser	•
Motor type	BLDC
Quiet operation	•
SmartDrive™ technology	•

Performance

Noise on standard cycle top drawer	42 dBA
------------------------------------	--------

Power Requirements

Amperage	10A
Electric circuit	3
Rated current	15 A
Supply frequency	60Hz
Supply voltage	100 - 120V

Product Dimensions

Depth	22 9/16 "
Height	34 - 36 3/8 "
Width	23 9/16 "

Wash Program Modifiers

Extra Dry	•
Quick	•
Sanitise	•

Wash modifiers	3
----------------	---

Wash Programs

Delicate	•
Eco	•
Fast	•
Heavy	•
Medium	•
Rinse	•
Wash programs	6

Water connection

Inlet water temperature	Max 140 °F
Supplied hose to suit 3/8" (9mm) male compression fitting	•
Water pressure	30kPa - 1000 kPa
Water supply	3/8" to suit Male Compression Fitting

SKU	82345
-----	-------

The product dimensions and specifications in this page apply to the specific product and model. Under our policy of continuous improvement, these dimensions and specifications may change at any time. You should therefore check with Fisher & Paykel's Customer Care Centre to ensure this page correctly describes the model currently available. © Fisher & Paykel Appliances Ltd 2020

Other product downloads available at fisherpaykel.com



A PEACE OF MIND SALE

24 Hours 7 Days a Week Customer Support

T 1.888.936.7872 W www.fisherpaykel.com

- [↓](#) DWG
- [↓](#) DXF
- [↓](#) Energy Label (English, Canadian French)
- [↓](#) Installation Guide (English)
- [↓](#) Installation Guide (Canadian French)
- [↓](#) California Warning Proposition 65 (English, Spanish, Canadian French, Chinese)
- [↓](#) Quick Start Guide (Canadian French)
- [↓](#) Revit
- [↓](#) Rhino
- [↓](#) Right To Repair Declaration (English, Canadian French)
- [↓](#) SketchUp
- [↓](#) User Guide (English)
- [↓](#) Installation Video

Where applicable:

All appliances use energy, and energy usage typically generates carbon emissions. **Fisher & Paykel Appliances' In-use Energy Carbon Emissions Estimate** indicates carbon emissions from a product's in-use energy. This is calculated either annually or per cycle, using the product's market-specific energy label energy consumption data multiplied by the carbon emissions factor for energy in your country or region.

Our In-use Energy Carbon Emissions Estimate is designed to assist customers in making informed purchasing decisions when comparing different Fisher & Paykel products. For example, a heat pump dryer typically has a lower In-use Energy Carbon Emissions Estimate than a vented dryer.