

90cm Series 7 Integrated French Door Refrigerator Freezer

Integrated



This large capacity refrigerator with bottom freezer seamlessly integrates into your kitchen, fitting flush into your cabinetry.

- ActiveSmart™ technology helps keep food fresher for longer by constantly maintaining the ideal temperature.
- Customise with your own kitchen cabinetry or purchase our stainless steel door panel accessory
- Spacious bottom freezer with full extension drawer gives easy access to frozen goods.

DIMENSIONS

Height	1798 mm
Width	896 mm
Depth	610 mm

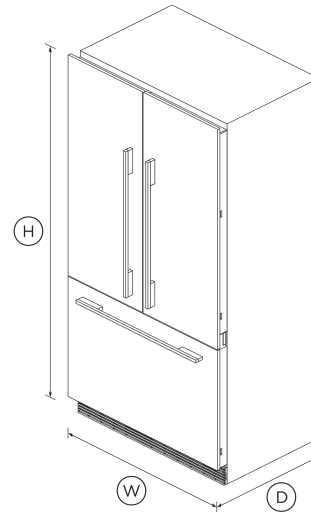

FEATURES & BENEFITS

ActiveSmart™ Foodcare

ActiveSmart™ Foodcare learns how you live. It is technology which understands how you use your refrigerator and adjusts temperature, airflow and humidity inside to help keep food fresher for longer.

Simple Storage

This refrigerator is designed to make it simple for you to store, access and remove food. Storage bins give you full access inside when they're pulled open and can be easily removed to clean. Our flexible shelving also gives you more storage options.

Clever energy

Your refrigerator adapts to daily use by cooling and defrosting only when needed. This ActiveSmart™ technology means better energy efficiency without compromising on food care.

Easy cleaning

Spill-safe secure glass shelves easily capture any drips or leaks and prevent them from falling on items below.

Easy installation

Our integrated products are easy to install, whether you are renovating your kitchen or designing a new one. Adjustable front and rear feet allow for uneven floors alongside adjustable door panels that can be customised to match your kitchen.

Design quality

Our refrigerators are designed and built using quality materials. We use real stainless steel, and solid glass for shelving.

SPECIFICATIONS

Accessories (sold separately)

Door panel set stainless steel	RD90A
Handle kit Classic	AHCLRD90A
Handle kit Contemporary round, aluminium	AHS-ASBI-A
Handle kit Contemporary square fine, aluminium	AHD5RD90A
Handle kit Contemporary square fine, black	AHD5RD90AB

Capacity

Volume freezer	145 L
Volume refrigerator	331 L

Connected Features

- Alerts and notifications •
- Education and onboarding •
- Remote operation •
- Software updates •

- Door alarm •
- Ice trays 1
- Large plastic bins •
- LED bin lighting •
- Slide Out Pastry Tray •
- Small plastic bins •

Variable Temp Compartment

- Bottle chill mode •

SKU 26876

Consumption

Energy rating **E**
 Energy usage **304kWh/year**
 In-use energy carbon emissions estimate **59.0kgCO2e/year**

Performance

- ActiveSmart™ Foodcare •
- Adaptive defrost •
- Frost free freezer •
- Humidity control system •
- Inverter controlled compressor •
- Sabbath mode •

The product dimensions and specifications in this page apply to the specific product and model. Under our policy of continuous improvement, these dimensions and specifications may change at any time. You should therefore check with Fisher & Paykel's Customer Care Centre to ensure this page correctly describes the model currently available. © Fisher & Paykel Appliances Ltd 2020

Features

- Adjustable door shelves 6
- Adjustable glass cantilevered shelves •
- Adjustable glass shelves 3
- Covered door shelves 2
- Door alarm •
- Fruit and vegetable bins 2
- Gallon door shelves 1
- LED lighting •
- Smart appliance •
- SmartTouch control panel •
- Soft close doors •
- Spill proof removable bins •
- Stackable bottle holders 4

Power requirements

Rated current **10 A**
 Supply frequency **50 Hz**
 Supply voltage **230 V**

Other product downloads available at fisherpaykel.com

- [↓](#) Product Information Sheet
- [↓](#) DWG
- [↓](#) DXF
- [↓](#) Declaration of Conformity (English)
- [↓](#) Energy Label
- [↓](#) Product Information Sheet
- [↓](#) Planning Guide (English)
- [↓](#) Revit
- [↓](#) Rhino
- [↓](#) SketchUp

Product dimensions

Depth **610 mm**
 Height **1798 mm**
 Width **896 mm**

Where applicable:

Freezer Features

- Bottle chill •

Product information

Unpackaged weight **138 kg**

All appliances use energy, and energy usage typically generates carbon emissions. **Fisher & Paykel Appliances' In-use Energy Carbon Emissions Estimate** indicates carbon emissions from a product's in-use energy. This is calculated either annually or per cycle, using the product's market-specific energy label energy consumption data multiplied by the carbon emissions factor for energy in your country or region.

Our In-use Energy Carbon Emissions Estimate is designed to assist customers in making informed purchasing decisions when comparing different Fisher & Paykel products. For example, a heat pump dryer typically has a lower In-use Energy Carbon Emissions Estimate than a vented dryer.



A PEACE OF MIND SALE
24 Hours 7 Days a Week Customer Support
T 08000 886 605 [Wwww.fisherpaykel.com](http://www.fisherpaykel.com)