

## 24" Series 11 Minimal Combi- Steam Oven

Minimal



<p>With a subtle black glass finish, this Contemporary style oven has 23 functions including steam-only, to effortlessly create healthy and delicious dishes.</p>

- Precise temperature control with steam-only cooking, convection-only, or a combination of both
- 23 oven functions including Steam, Sous Vide, Air Fry and Vent Bake
- Designed to match with companion products such as vacuum seal drawers
- Guided touchscreen cooking makes it simple to cook by food, function or recipe

### DIMENSIONS

|        |           |
|--------|-----------|
| Height | 23 9/16 " |
| Width  | 23 7/16 " |
| Depth  | 22 1/4 "  |

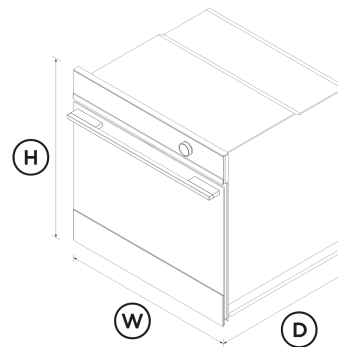

### FEATURES & BENEFITS

#### Design Freedom

Every detail has been carefully crafted from the finest materials to support a considered kitchen design. With a subtle black finish, this Minimal Style oven blends seamlessly, enhancing your kitchen design without dominating it. It's understated and elegant, whether on its own or part of a matching appliance set. Pair with a Vacuum Seal Drawer for the ultimate kitchen solution. Pair with a Vacuum Seal Drawer for the ultimate kitchen solution.

#### From Steam to Sous Vide

Fine amounts of steam are released with accuracy and precision at a range of temperatures, to ensure food is cooked gently and evenly. Perfect for entertaining, you can sous vide proteins such as steak and salmon before guests arrive, and simply sear when ready to serve. The flexibility of timing and accuracy of temperature control ensure perfect, predictable results every time.

#### Gentle and healthy

Steam functions allow you to cook food in its own juices to retain nutrients, moisture and flavor. With five steam-only cooking functions including Sous Vide, plus four combi-steam functions, this oven lets you enjoy the benefits of flavorful and healthy restaurant-quality meals at home.

#### Multi-Function Flexibility

A truly multiple function oven where both steam-only and convection-only cooking mediums can stand on their own merits. You have the freedom to choose - whether it's dry heat or moist heat, or a combination of the two - each delivering different cooking results. Purchase our Wireless Temperature Sensor accessory and precisely monitor cooking in real time (accessory sold separately).

#### Cook With Confidence

Using the intuitive touchscreen interface, you can cook with a favorite method, a hero ingredient, or a go-to cooking function or recipe. Your oven will guide you through steps, or change temperature and heat type automatically, depending on your selection.

#### Reheat and restore

Reduce household food waste by reheating foods with steam, which helps to regenerate moisture levels and ensure meals come out fresh and delicious. Use Steam Regenerate to reheat leftover meals such as roast and risotto, while Crisp Regenerate is perfect for refreshing pastries, bread and pizza.

#### Exceptional convection performance

AeroTech™ circulates heat evenly for a consistent temperature throughout the cavity, while ActiveVent technology ensures optimized moisture levels when using convection functions. Achieve perfect results even when you're using multiple shelves.

**SPECIFICATIONS**

**Accessories (included)**

|                                |                               |
|--------------------------------|-------------------------------|
| Broil grid                     | 1                             |
| Broil pan                      | 1                             |
| Broil rack                     | 1                             |
| Descal solution                | <b>2 sachets, Part 580925</b> |
| Full extension sliding shelves | <b>2 sets</b>                 |
| Large steam dish               | 1                             |
| Perforated small pan           | 1                             |
| Wired temperature sensor       | 1                             |

**Capacity**

|                 |                  |
|-----------------|------------------|
| Shelf positions | <b>6</b>         |
| Total capacity  | <b>3 cu ft</b>   |
| Usable capacity | <b>2.5 cu ft</b> |

**Cleaning**

|                                 |   |
|---------------------------------|---|
| Acid resistant graphite enamel  | • |
| Descal cycle                    | • |
| Drying cycle                    | • |
| Removable oven door             | • |
| Removable oven door inner glass | • |

Removable side ladders •

**Controls**

|   |                   |
|---|-------------------|
| Adjustable audio and display settings   | •                 |
| Automatic cooking/minute timer          | •                 |
| Automatic pre-set temperatures          | •                 |
| Celsius/Fahrenheit temperature          | •                 |
| Delay start                             | •                 |
| Electronic clock                        | •                 |
| Electronic oven control                 | •                 |
| Guided cooking by food type and recipes | •                 |
| Intuitive touchscreen display           | •                 |
| Multi-language display                  | <b>UK English</b> |
| Sabbath mode with Star K certification  | •                 |
| Smart appliance                         | •                 |
| Temperature sensor                      | •                 |

**Functions**

|                     |           |
|---------------------|-----------|
| Aero Broil          | •         |
| Aero™ Bake          | •         |
| Air fry             | •         |
| Bake                | •         |
| Classic bake        | •         |
| Crisp regenerate    | •         |
| Dehydrate           | •         |
| Number of functions | <b>23</b> |
| Pastry Bake         | •         |
| Pizza bake          | •         |
| Roast               | •         |

|                          |   |
|--------------------------|---|
| Slow cook                | • |
| Sous vide                | • |
| Steam                    | • |
| Steam defrost            | • |
| Steam proof              | • |
| Steam regenerate         | • |
| True Aero                | • |
| True Aero + High steam   | • |
| True Aero + Low steam    | • |
| True Aero + Medium steam | • |
| Vent bake                | • |
| Warm                     | • |

**Performance**

|                          |                    |
|--------------------------|--------------------|
| ActiveVent™ system       | •                  |
| AeroTech™ technology     | •                  |
| Automatic rapid pre-heat | •                  |
| Broil power              | <b>3000 W</b>      |
| Broil width              | <b>15 "</b>        |
| SteamTechnology          | •                  |
| Temperature range        | <b>95°F -445°F</b> |
| Whisper Quiet Cooking    | •                  |

**Power Requirements**

|                |                      |
|----------------|----------------------|
| Amperage       | <b>16.6 - 19.4 A</b> |
| Supply voltage | <b>208 - 240 V</b>   |

**Product Dimensions**

|        |           |
|--------|-----------|
| Depth  | 22 1/4 "  |
| Height | 23 9/16 " |
| Width  | 23 7/16 " |

---

#### Safety

|                          |   |
|--------------------------|---|
| Balanced oven door       | • |
| Catalytic venting system | • |
| Control panel key lock   | • |
| CoolTouch door           | • |
| Non-tip shelves          | • |

---

SKU 82254

#### Where applicable:

All appliances use energy, and energy usage typically generates carbon emissions. **Fisher & Paykel Appliances' In-use Energy Carbon Emissions Estimate** indicates carbon emissions from a product's in-use energy. This is calculated either annually or per cycle, using the product's market-specific energy label energy consumption data multiplied by the carbon emissions factor for energy in your country or region.

Our In-use Energy Carbon Emissions Estimate is designed to assist customers in making informed purchasing decisions when comparing different Fisher & Paykel products. For example, a heat pump dryer typically has a lower In-use Energy Carbon Emissions Estimate than a vented dryer.



**A PEACE OF MIND SALE**  
**24 Hours 7 Days a Week Customer Support**  
 T 1.888.936.7872 W [www.fisherpaykel.com](http://www.fisherpaykel.com)

The product dimensions and specifications in this page apply to the specific product and model. Under our policy of continuous improvement, these dimensions and specifications may change at any time. You should therefore check with Fisher & Paykel's Customer Care Centre to ensure this page correctly describes the model currently available. © Fisher & Paykel Appliances Ltd 2020

#### Other product downloads available at [fisherpaykel.com](http://fisherpaykel.com)

- [↓](#) DWG
- [↓](#) DXF
- [↓](#) Data Sheet (English)
- [↓](#) Installation Guide (English)
- [↓](#) Installation Guide (Canadian French)
- [↓](#) Right To Repair Declaration (English, Canadian French)
- [↓](#) User Guide (English)
- [↓](#) User Guide (English)