

Freestanding Quad Door Refrigerator Freezer, 79cm, 498L

Series 7 | Contemporary

Stainless Steel | French hinge



With flexible storage and a sleek, slimline design, this model will complement any kitchen perfectly.

- Recessed handles for a sleek look to complement any kitchen design
- ActiveSmart™ Foodcare helps keep food fresher for longer by maintaining the ideal temperature
- Exceptional 5 star energy rating

- Wi-Fi enabled and works with the SmartHQ™ app for remote control and notifications

DIMENSIONS

Height	1790mm
Width	790mm
Depth	692mm

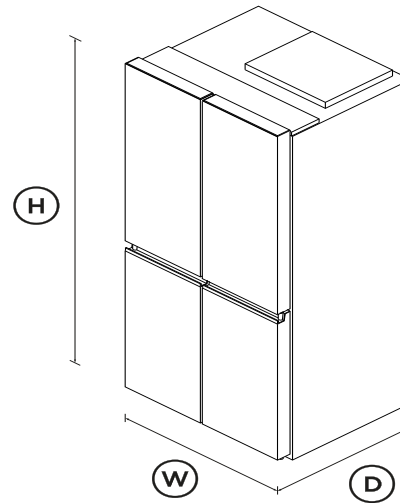

FEATURES & BENEFITS

ActiveSmart™ Foodcare

ActiveSmart™ Foodcare learns how you live. It's technology which understands how you use your refrigerator and adjusts temperature, airflow and humidity inside to help keep food fresher for longer.

Clever energy

With an exceptional 5 star energy rating, this refrigerator adapts to daily use by cooling and defrosting only when necessary. This means it uses the energy it needs without compromising on food care.

Slimline design

With a sleek, slimline design and recessed handles, this quad door refrigerator is perfect for compact kitchens. Choose from natural stainless steel or elegant black stainless steel to suit your kitchen aesthetic.

HUMIDITY CONTROL

The humidity bin in this refrigerator is designed to help extend the freshness of your produce. It creates a unique microclimate within the bin, compared to the main refrigerator compartment, ensuring your fruits and vegetables stay fresher for longer.

Design quality

Our refrigerators are designed and built using robust, quality materials, with stainless steel exteriors and solid glass for the interior shelving.

SIMPLE STORAGE

This refrigerator is designed to make it simple for you to store, access and remove food. Storage bins give you full access inside when they're pulled open and can be easily removed to clean. Our flexible shelving also gives you more storage options.

SPECIFICATIONS

Capacity

Volume	498L
Volume freezer	174L
Volume refrigerator	324L

Consumption

Energy rating	5 star
Energy usage	320kWh/year

Energy usage refrigerator	320kWh/year
In-use energy carbon	208.4kgCO2e/year

Features

Adjustable door shelves	6
Adjustable glass cantilevered	•
Door alarm	•
Front levelling feet	•
Fruit and vegetable bins	1
Full extension runners	•
LED lighting	•
Rear rollers	•
Wi-Fi capable	•

Freezer Features

Bottle chill	•
Door alarm	•
Fast freeze	•
Freezer bins	4
Freezer trays	2

Installation Dimensions

Minimum inside width of	830mm
Minimum internal depth of	640mm
Minimum internal height of	1810mm

Performance

ActiveSmart™ Foodcare	•
Automatic defrost	•
Eco friendly R600a refrigerant	•

Frost free freezer	•
Humidity control system	•
Inverter controlled compressor	•
Noise emissions	40dBA
Sabbath mode	•

Power requirements

Rated current	2A
Supply frequency	50Hz
Supply voltage	220-240V

Product dimensions

Depth	692mm
Depth (less door)	614mm
Height	1790mm
Width	790mm

Warranty

Parts and labour	2 years
------------------	----------------

SKU	26621
-----	--------------

The product dimensions and specifications in this page apply to the specific product and model. Under our policy of continuous improvement, these dimensions and specifications may change at any time. You should therefore check with Fisher & Paykel's Customer Care Centre to ensure this page correctly describes the model currently available. ? Fisher & Paykel Appliances Ltd 2020

Other product downloads available at fisherpaykel.com

- [↓](#) User Guide Quad Door Refrigerator Freezer
- [↓](#) Energy Label Freestanding Quad Door Refrigerator Freezer
- [↓](#) Installation Guide ActiveSmart Refrigerator
- [↓](#) Data Sheet Quad Door Refrigerator Freezer



A PEACE OF MIND SALE

24 Hours 7 Days a Week Customer Support

T 1300 650 590 Wwww.fisherpaykel.com