

# Integrated Refrigerator Freezer, 60cm

Series 5 | Integrated

Panel Ready | Reversible hinge



A compact refrigerator with bottom freezer, ready for you to add your custom cabinetry for a flush fit.\*

- Customise with your own kitchen cabinetry or purchase our stainless steel door panel accessory
- Choose a left or right hinge to suit your kitchen's layout
- Spacious bottom freezer with easy-slide internal drawers to separate storage

## DIMENSIONS

Height	1773mm
Width	555mm
Depth	544mm

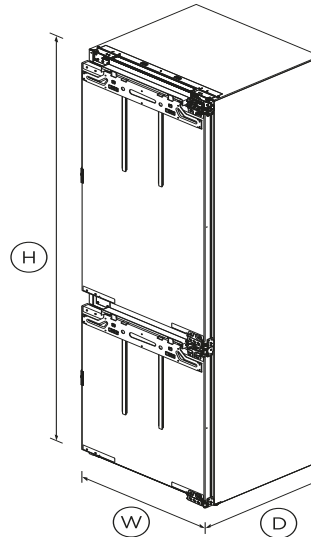

## FEATURES & BENEFITS

### VARIABLE TEMPERATURE DRAWER

The variable temperature drawer is designed to allow optimal storage of fresh meat, produce, deli and dairy products at their ideal temperatures. Operating separately from the refrigerator and freezer, the drawer can be set at a temperature between -5°C and 3°C, with 3°C ideal for fruit and vegetables, -1.1°C perfect for fresh meats, and -3°C for fast chilling. Helping to keep your food fresher for longer.

### FAST FREEZING

When freezing fresh food, the freshness, texture and taste are retained with rapid freezing. The fast freeze function boosts the freezing speed by dropping the freezer to its coldest temperature (-24°C) for 12 hours, ensuring food is fast and fully frozen. Plus, you never need to worry about defrosting your fridge with the built-in frost-free function.

### Simple Storage

This fridge is designed to make it simple for you to store, access and remove food. Storage bins give you full access inside when they're pulled open and can be easily removed to clean. Adjustable shelving in the main cavity and door provide flexible storage options.

### Easy Installation

Our integrated products are easy to install, whether you are renovating your kitchen or designing a new one. They are designed for minimal gaps with adjustable door panels that can be customised to match your kitchen.

### Beautiful lighting

Bright LEDs light up the ceiling, shelves, bins and tray in both refrigerator and freezer, making it easy to find your food and creating a welcoming glow in your kitchen for those midnight snacks.

### Easy Cleaning

Spill-safe secure glass shelves easily capture any drips or leaks and prevent them from falling on items below.

### ActiveSmart™ Foodcare

ActiveSmart™ Foodcare learns how you live. It's technology which understands how you use your refrigerator and adjusts temperature, airflow and humidity inside to help keep food fresher for longer.

## SPECIFICATIONS

### Accessories (sold separately)

Toe kick stainless steel 610mm

AKRS06110

**Capacity**

Total net volume	<b>236L</b>
Volume freezer	<b>67L</b>
Volume refrigerator	<b>136L</b>
Volume variable temperature	<b>33L</b>

**Consumption**

Energy consumption	<b>235kWh/year</b>
Energy rating	<b>E</b>

**Features**

Adjustable door shelves	<b>3</b>
Adjustable glass shelves	<b>2</b>
Door alarm	<b>•</b>
Egg Trays	<b>2</b>
LED lighting	<b>•</b>
Rapid cool function	<b>•</b>
SmartTouch control panel	<b>•</b>

**Freezer Features**

Fast freeze	<b>•</b>
Freezer bins	<b>3</b>
Ice trays	<b>1</b>
Large plastic bins	<b>•</b>

**Performance**

ActiveSmart™ Foodcare	<b>•</b>
Frost free freezer	<b>•</b>
Holiday mode	<b>•</b>

Humidity control system	<b>•</b>
Inverter controlled compressor	<b>•</b>
Noise emissions	<b>39dBA</b>
Noise emissions class	<b>C</b>

**Power requirements**

Rated current	<b>10A</b>
Supply frequency	<b>50Hz</b>
Supply voltage	<b>230V</b>

**Product dimensions**

Depth	<b>544mm</b>
Height	<b>1773mm</b>
Width	<b>555mm</b>

**Warranty**

Parts and labour	<b>5 years</b>
Sealed system parts only	<b>5 years</b>

SKU	<b>24931</b>
-----	--------------

The product dimensions and specifications in this page apply to the specific product and model. Under our policy of continuous improvement, these dimensions and specifications may change at any time. You should therefore check with Fisher & Paykel's Customer Care Centre to ensure this page correctly describes the model currently available. ? Fisher & Paykel Appliances Ltd 2020

**A PEACE OF MIND SALE****24 Hours 7 Days a Week Customer Support****T 08000 886 605 Wwww.fisherpaykel.com**