

Oven, 60cm, 9 Function

Series 7 | Contemporary

Stainless Steel



With beautiful contemporary styling, this compact oven will complement your kitchen design and is perfect for smaller kitchens.

- 55L total capacity
- Nine oven functions including Roast and Pastry Bake

DIMENSIONS

Height	458mm
Width	597mm
Depth	565mm

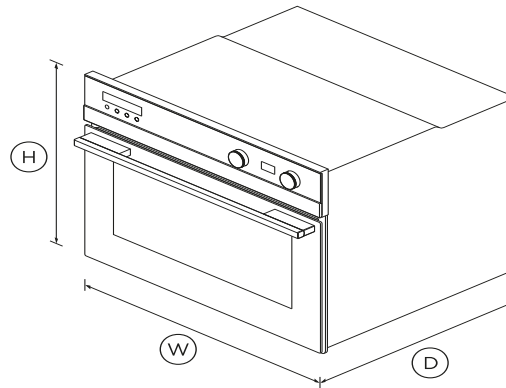

FEATURES & BENEFITS

OVEN FUNCTIONS

This built-in oven has nine functions with pre-set temperatures, including Roast, Pastry Bake and Fan Forced, allowing you to use a variety of cooking styles.

SIZED TO SUIT

This Fisher & Paykel compact built-in oven provides 55L of capacity. Our compact ovens are perfect for smaller kitchens and have all the features of a conventional built-in oven.

EASY CLEANING

This built-in oven has catalytic liners that break down oil and fat splashes during cooking so you don't have to spend hours cleaning.

SAFE AND SOUND

The CoolTouch door with triple glazing and cooling system is safe to touch from the outside, protecting your hands and the surrounding cabinetry.

EVEN HEAT

Our built-in ovens feature AeroTech - a technology that circulates heat evenly, ideal for multi-shelf cooking.

DESIGNED TO MATCH

With their premium handle styling and stainless steel finish, our built-in ovens are designed to match the rest of Fisher & Paykel's kitchen appliance family.

SPECIFICATIONS

Accessories

Catalytic panels	•
Roasting dish	1
Smokeless grill tray	1
Step down wire shelf	1
Telescopic sliding runners	1 set

Capacity

Shelf positions	4
Total capacity	55L
Usable capacity	45L

Cleaning

Acid resistant graphite enamel	•
--------------------------------	---

- Drop down grill element
- Removable oven door inner
- Removable shelf runners

- Grill power **3000W**
- Whisper quiet cooking

making informed purchasing decisions when comparing different Fisher & Paykel products. For example, a heat pump dryer typically has a lower In-use Energy Carbon Emissions Estimate than a vented dryer.

Controls

- Audio feedback
- Automatic cooking/minute
- Automatic pre-set
- Celsius/Fahrenheit
- Dial with illuminated halo
- Electronic capacitive touch
- Electronic clock
- Electronic oven control
- Halogen lights

Power requirements

- Amperage **15A**

Product dimensions

- Depth **565mm**
- Height **458mm**
- Width **597mm**

Safety

- Balanced oven door
- Control panel key lock
- CoolTouch door
- Non-tip shelves

Functions

- Bake
- Classic bake
- Fan bake
- Fan forced
- Fan grill
- Grill
- Number of functions **9**
- Pastry Bake
- Roast
- Warm

- SKU **81497**

The product dimensions and specifications in this page apply to the specific product and model. Under our policy of continuous improvement, these dimensions and specifications may change at any time. You should therefore check with Fisher & Paykel's Customer Care Centre to ensure this page correctly describes the model currently available. Fisher & Paykel Appliances Ltd 2020

Where applicable:

All appliances use energy, and energy usage typically generates carbon emissions. **Fisher & Paykel Appliances' In-use Energy Carbon Emissions Estimate** indicates carbon emissions from a product's in-use energy. This is calculated either annually or per cycle, using the product's market-specific energy label energy consumption data multiplied by the carbon emissions factor for energy in your country or region.

Our In-use Energy Carbon Emissions Estimate is designed to assist customers in

Performance

- AeroTech™ technology
- Automatic rapid pre-heat

Other product downloads available at fisherpaykel.com

- [↓](#) Service & Warranty
- [↓](#) User Guide Built in Oven
- [↓](#) User Guide Wall Oven
- [↓](#) Installation Guide Built-In Oven
- [↓](#) Data Sheet Oven



A PEACE OF MIND SALE

24 Hours 7 Days a Week Customer Support

T 0800 372 273 **W**www.fisherpaykel.com