

24" Series 5 Contemporary 4 Burner Gas Range, Natural Gas

Contemporary



Perfect for compact kitchens, but with plenty of room to cook a large family roast and all the sides.

- Four burner gas cooktop, with wok burner
- Gas oven with 2.5 cu.ft total capacity and four oven functions including Defrost and Convection Bake

DIMENSIONS

Height 35 7/16 - 36 7/32 "

Width 23 7/8 "
Depth 24 3/32 "

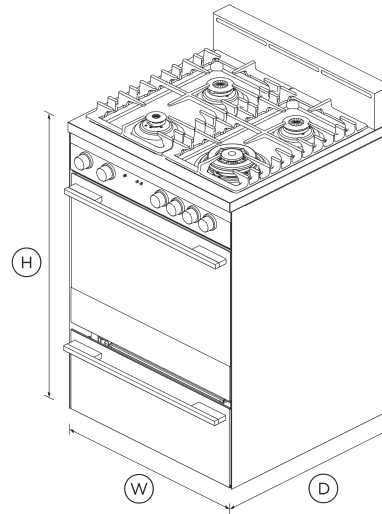

FEATURES & BENEFITS

Cooking Flexibility

This freestanding gas range has four functions with pre-set temperatures, including Bake, Broil and Convection Bake allowing you to use a variety of cooking styles.

Sized To Suit

Designed for multi-shelf cooking, this freestanding range provides 2.5 cu ft of total capacity, enough room for a large family roast.

Precise Control

The consistent flame and heat distribution of the gas burners combined with highly responsive dials offer precise heat control. Perfect a slow simmer for sauces or an intense heat for searing steaks.

Easy Cleaning

Cleaning is quick and simple. The cooktop is easy to clean as it is made from a single piece of stainless steel that contains spills. The oven door and its inner pane of glass can be removed for easy cleaning.

Safe And Sound

The double glazed door keeps the heat on the inside, protecting your hands and surrounding cabinetry. The gas cooktops flame failure safety device automatically turns off the gas if the flame is accidentally extinguished.

Complementary Design

With their black reflective glass and stainless steel finish, our freestanding cookers are designed to match the rest of Fisher & Paykel's kitchen appliance family.

SPECIFICATIONS

Accessories (included)

Step down wire shelf

Accessories (sold separately)

Kick strip, stainless steel (optional)	KICKOR36X1
Wok grate included	Yes

Burner ratings

Auxiliary burner (natural gas)	3500BTU
Semi-rapid burner (natural gas)	6000BTU
Triple ring wok burner (natural gas) x2	12000BTU

Capacity

Shelf positions **3**

Cleaning

- Acid resistant graphite enamel •
 - Removable oven door •
 - Removable oven door inner door glass •
-

Controls

- Automatic cooking/minute timer •
 - Electronic clock •
-

Oven features

- Cooling Fan Warning Light •
 - Electronic ignition •
-

Oven functions

- Bake •
 - Broil •
 - Convection bake •
 - Defrost •
 - Grill •
-

Oven performance

Broil **8500 BTU**

Power requirements

Amperage **15 A**
 Supply frequency **60 Hz**
 Supply voltage **120 V**

Product dimensions

Depth **24 3/32 "**
 Height **35 7/16 - 36 7/32 "**
 Width **23 7/8 "**

Rangetop features

- Cast iron trivets •
 - LPG / Natural Gas compatible •
-

Safety

- ADA compliant •
 - Advanced cooling system •
 - Anti-tilt bracket •
 - Door and cavity cooling system •
 - Glazed door •
 - Non-tip shelves •
-

SKU **81554**

The product dimensions and specifications in this page apply to the specific product and model. Under our policy of continuous improvement, these dimensions and specifications may change at any time. You should therefore check with Fisher & Paykel's Customer Care Centre to ensure this page correctly describes the model currently available. © Fisher & Paykel Appliances Ltd 2020

Other product downloads available at fisherpaykel.com

- [↓](#) DXF
- [↓](#) Data Sheet (English)
- [↓](#) DWG
- [↓](#) Right To Repair Declaration (English, Canadian French)

Where applicable:

All appliances use energy, and energy usage typically generates carbon emissions. **Fisher & Paykel Appliances' In-use Energy Carbon Emissions Estimate** indicates carbon emissions from a product's in-use energy. This is calculated either annually or per cycle, using the product's market-specific energy label energy consumption data multiplied by the carbon emissions factor for energy in your country or region.

Our In-use Energy Carbon Emissions Estimate is designed to assist customers in making informed purchasing decisions when comparing different Fisher & Paykel products. For example, a heat pump dryer typically has a lower In-use Energy Carbon Emissions Estimate than a vented dryer.



A PEACE OF MIND SALE
24 Hours 7 Days a Week Customer Support
 T 1.888.936.7872 W www.fisherpaykel.com