

30" Series 9 Professional 4 Burner Dual Fuel Self-Cleaning Range, LPG

Professional



Get the best of gas and convection technology in this striking range with intuitive touchscreen and specialized cooking functions.

- Guided cooking using your touchscreen makes it simple to cook by food, function or recipe.
- Top burner heat of 19,000 BTU, for seriously fast boiling
- 4 cu ft total oven capacity
- Beautiful LED halo-illuminated dials provide information at a glance

DIMENSIONS

| | |
|--------|-------------------|
| Height | 35 3/4 - 36 3/4 " |
| Width | 29 7/8 " |
| Depth | 29 1/8 " |

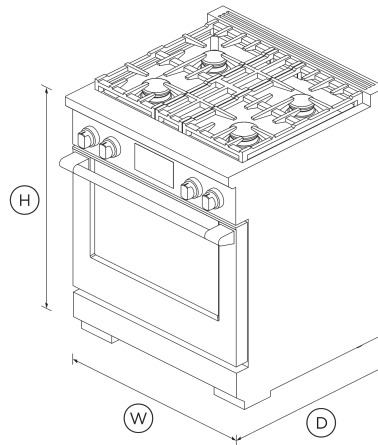

FEATURES & BENEFITS

Cook With Confidence

Our touchscreen interface provides an intuitive guided cooking experience that helps deliver perfect results, whether you've been cooking all your life or just starting out. Cook with a favorite method, a hero ingredient, or a go-to cooking function or recipe. The screen tilts for improved ergonomics and optimal visibility while cooking.

Generous Capacity

Featuring a generous total capacity of 4 cu ft, with enough room to fit a 26 lb turkey, or to cook several dishes at once.

Cooking Flexibility

No matter what you're cooking, you've got the right heat to get perfect results. Each of the 15 oven functions have been extensively researched and carefully designed to cater to a broad range of dishes and cooking styles. The handy food probe helps you monitor your progress.

Cooktop Power

Sealed dual flow burners deliver cooktop power up to 19,000 BTU for seriously fast boiling, and precise 140°F full surface, low temperature cooking with the gentlest of flames.

Design Quality

This range has craftsmanship in every detail, with real stainless steel, cast-iron grates, and beautifully weighted, halo illuminated dials. Each cavity features incandescent lights and full extension telescopic racks. From the robust legs to the powerful cooktop, this Range is built to last.

Easy To Clean

The oven features a self-cleaning function and self-clean proof side racks, which don't need to be removed when using this function.

SPECIFICATIONS

Accessories (included)

- Adjustable feet covers
- Branded coin end cap

Accessories (sold separately)

Square handle option **AH-R30**

Burner ratings

| | |
|----------------------|------------------|
| Maximum burner power | 19000 BTU |
| Power back left | 13000BTU |
| Power back right | 13000BTU |
| Power front left | 19000BTU |
| Power front right | 15000BTU |
| Total cooktop power | 60000 BTU |

Capacity

| | |
|-----------------|------------------|
| Shelf positions | 5 |
| Total capacity | 4 cu ft |
| Usable capacity | 3.3 cu ft |

Cleaning

| | |
|------------------------------|----------|
| Easy clean porcelain basepan | • |
| Pyrolytic self-clean | • |

Consumption

| | |
|---|------------------------|
| Energy usage | 490kWh/year |
| In-use energy carbon emissions estimate | 56.5kgCO2e/year |

Controls

| | |
|----------------------------|----------|
| Dial with illuminated halo | • |
| Electric circuit | 4 |
| High resolution display | • |
| Metal illuminated dials | • |
| Multi-language interface | • |
| Sabbath mode | • |

Gas Requirements

| | |
|-----------------------|---------------------------------|
| Fitting and pipe | ½ NPT, min. ⅝" flex line |
| Supply Pressure (LPG) | 11" to 14" W.C |

Main oven functions

| | |
|------|----------|
| Warm | • |
|------|----------|

Oven features

| | |
|---|----------|
| Auto re-ignition system | • |
| Broil pan | • |
| Concealed element | • |
| Electronic oven control | • |
| Food probe | • |
| Full extension telescopic sliding shelves | • |
| Titanium coated, illuminated metal dials | • |

Oven functions

| | |
|---------------------|-----------|
| Air fry | • |
| Bake | • |
| Classic bake | • |
| Clean | • |
| Convection bake | • |
| Convection Broil | • |
| Number of functions | 15 |
| Pastry bake | • |
| Pizza bake | • |
| Rapid proof | • |

| | |
|-----------------|----------|
| Roast | • |
| Slow cook | • |
| True convection | • |
| Warm | • |

Oven performance

| | |
|-----------------------------------|-----------------|
| Bake power | 3500W |
| Broil | 4000 BTU |
| Main oven - True convection power | 2500 W |

Power requirements

| | |
|------------------|---|
| Connection | 4-prong grounding type [NEMA 14-50 plug] |
| Service | 30 A |
| Supply frequency | 60 Hz |
| Supply voltage | 240 V |

Product details

| | |
|------------------|------------|
| Self Cleaning Sf | Yes |
|------------------|------------|

Product dimensions

| | |
|---------------------------|--------------------------|
| Depth | 29 1/8 " |
| Depth (excluding handles) | 2918 mm |
| Height | 35 3/4 - 36 3/4 " |
| Width | 29 7/8 " |

Rangetop features

Vent trim included •

Recommended Back Guards Ventilation

Combustible situation **BGRV3-3030H**

Non combustible situation **BGRV2-3030 / BGRV2-1230**

Recommended hood **HCB30-6_N (Professional Range Hood)**

Safety

ADA compliant •

Full extension telescopic sliding shelves •

Secondary oven features

Food probe •

SKU 82944

The product dimensions and specifications in this page apply to the specific product and model. Under our policy of continuous improvement, these dimensions and specifications may change at any time. You should therefore check with Fisher & Paykel's Customer Care Centre to ensure this page correctly describes the model currently available. © Fisher & Paykel Appliances Ltd 2020

- [↓ DWG](#)
- [↓ DWG](#)
- [↓ DWG](#)
- [↓ DXF](#)
- [↓ DXF](#)
- [↓ DXF](#)
- [↓ Archicad](#)
- [↓ Energy Label](#)
- [↓ Installation Guide \(English\)](#)
- [↓ Installation Guide \(Canadian French\)](#)
- [↓ Planning Guide - 30" Professional Ranges & Backguards \(English\)](#)
- [↓ Revit](#)
- [↓ Rhino](#)
- [↓ Right To Repair Declaration \(English, Canadian French\)](#)
- [↓ SketchUp](#)
- [↓ User Guide \(English\)](#)
- [↓ User Guide \(Canadian French\)](#)
- [↓ User Guide \(Canadian French\)](#)

Where applicable:

All appliances use energy, and energy usage typically generates carbon emissions. **Fisher & Paykel Appliances' In-use Energy Carbon Emissions Estimate** indicates carbon emissions from a product's in-use energy. This is calculated either annually or per cycle, using the product's market-specific energy label energy consumption data multiplied by the carbon emissions factor for energy in your country or region.

Our In-use Energy Carbon Emissions Estimate is designed to assist customers in making informed purchasing decisions when comparing different Fisher & Paykel products. For example, a heat pump dryer typically has a lower In-use Energy Carbon Emissions Estimate than a vented dryer.



A PEACE OF MIND SALE
 24 Hours 7 Days a Week Customer Support
 T 1.888.936.7872 W www.fisherpaykel.com

Other product downloads available at fisherpaykel.com