

# Dual Fuel Range, 36", 4 Burners with Griddle

Series 9 | Professional

Stainless Steel | Natural gas



Get the best of gas and convection technology, with a high powered four burner gas cooktop and large capacity oven.

- Top burner heat of 23,500 BTU, for seriously fast boiling
- Convection oven with 4.8 cu ft total capacity
- Non-tip full-extension shelves for safe removal of hot dishes

## DIMENSIONS

Height	35 3/4 - 36 3/4"
Width	35 7/8"
Depth	29 1/8"

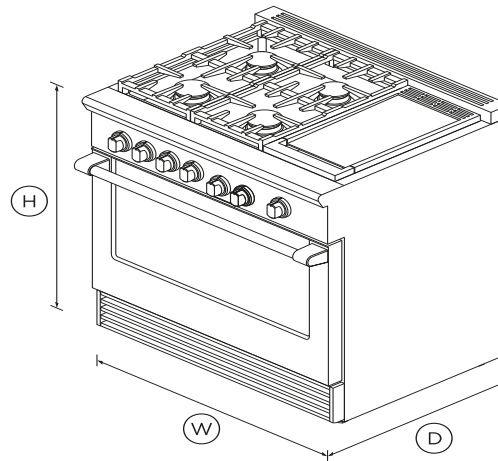

## FEATURES & BENEFITS

### Cooktop power

Sealed Dual Flow Burners™ deliver cooktop power up to 23,500 BTU (NG models) for seriously fast boiling right down to a precise 140°F full surface simmer with the gentlest of flames.

### Total control

Precise control across high and low settings is delivered through the halo-illuminated cooktop dials. The ovens have true convection and electronic oven control for precise and consistent temperatures.

### Consistent broiling

The Dual Fuel Range broiler provides an even heat that covers a very large surface area — perfect for browning a fully loaded oven tray.

### Easy to clean

The Dual Fuel Range oven has a self-cleaning function and removable side racks. The cooktop has sealed burners and an encapsulated cooking surface with a commercial-style stainless steel finish.

### Instant visibility

Control dials have halo-illumination glowing white – heating up; orange – temperature reached; red – self-cleaning mode. The oven is illuminated by two powerful incandescent lights.

### Cooking flexibility

The cooktop is designed for easy access to any burner with grates you can smoothly slide pots across. The oven is large enough to hold full size baking sheets.

## SPECIFICATIONS

### Accessories (sold separately)

Square handle option	AH-R36
----------------------	--------

### Burner ratings

Maximum burner power	23500 BTU
Power back left	18500BTU
Power back right	18500BTU
Power front left	23500BTU
Power front right	18500BTU
Power griddle	18000BTU
Total cooktop power	97000 BTU

### Capacity

Shelf positions (main oven) 5

**Cleaning**

Pyrolytic self-clean •

**Controls**

Electric circuit 4 wire

Metal illuminated dials •

**Gas Requirements**

Fitting and pipe ½ NPT, min. 5/8" flex line

Supply Pressure (natural gas) 6" to 9" W.C

**Oven features**

Auto re-ignition system •

Concealed element •

Electronic oven control •

Full extension telescopic •

Internal light •

Large broil pan •

True convection •

**Oven functions**

Bake •

Broil •

Clean •

Convection Broil •

Convection bake •

Number of functions 6

Self-clean function •

True convection •

**Oven performance**

Bake power 4600

Main oven - True convection 2500W

**Power requirements**

Rated current 30A

Supply frequency 60Hz

**Product dimensions**

Depth 29 1/8"

Height 35 3/4 - 36 3/4"

Width 35 7/8"

**Rangetop features**

Sealed range top •

Vent trim included •

**Safety**

Full extension telescopic •

SKU 71368

The product dimensions and specifications in this page apply to the specific product and model. Under our policy of continuous improvement, these dimensions and specifications may change at any time. You should therefore check with Fisher & Paykel's Customer Care Centre to ensure this page correctly describes the model currently available. ? Fisher & Paykel Appliances Ltd 2020

**Other product downloads available at fisherpaykel.com**

- [↓](#) Service & Warranty
- [↓](#) User Guide EN
- [↓](#) Installation Guide EN / Guide d'installation FR
- [↓](#) Data Sheet Dual Fuel Range
- [↓](#) Planning Guide Dual Fuel Range



**A PEACE OF MIND SALE**

24 Hours 7 Days a Week Customer Support

T 1.888.936.7872 W www.fisherpaykel.com