

# 30" Series 7 Contemporary Self-Cleaning Oven, 14 Function

Contemporary



With beautiful Contemporary styling and a generous 4.1 cu ft total capacity, this built-in oven helps to ensure that every dish you create is cooked to perfection.

- 4.1 cu ft total capacity with 14 oven functions including Pastry Bake, Roast and Air Fry
- Even heat circulation with AeroTech™, ideal for multi-shelf cooking
- Pyrolytic self-cleaning function breaks down food residue for an easy clean

- Guided cooking capability offers helpful tips for different food types

## DIMENSIONS

Height	27 3/16 "
Width	29 15/16 "
Depth	23 15/16 "

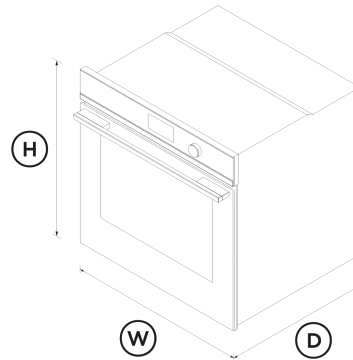

## FEATURES & BENEFITS

### Multi-Function Flexibility

Each function has been perfected to ensure that no matter what you're cooking, you've got the right heat to match. This built-in oven has 14 functions including Pastry Bake, Pizza Bake, Roast, Slow Cook and Air Fry, allowing you to use a variety of cooking styles.

### Generous Capacity

With an incredible 4.1 cu ft total capacity in each oven, you can create several perfectly cooked dishes at once using multiple shelves.

### Cook With Confidence

The intuitive 2.4" screen provides an intuitive guided cooking experience that helps to deliver perfect results, whether you've been cooking all your life or are just starting out. Cook by food type and allow your oven to guide you through steps, or change temperature and heat type automatically, depending on your selection.

### Exceptional Performance

AeroTech™ circulates heat evenly for a consistent temperature throughout the cavity, helping you ensure perfect results even when cooking on multiple shelves.

### Multi-Function Flexibility

Each function has been tailored, tested and perfected to ensure that no matter what you're cooking, you've got the right heat to match. The Wireless Temperature Sensor precisely monitors cooking in real time, giving you complete control.

### Self-Cleaning

Our pyrolytic self-cleaning technology breaks down food residue at a very high temperature, leaving a light ash that's easily removed with a damp cloth.

### Design Freedom

Designed to fit seamlessly into your kitchen, this built-in oven features premium materials and detailing to support a cohesive, considered kitchen design.

## SPECIFICATIONS

### Accessories (included)

Broil grid	1
Broil pan	1
Broil rack	1
Full extension sliding shelves	2
Pyrolytic proof shelf runners	•
Wired temperature sensor	1

**Capacity**

Total capacity	4.1 cu ft
----------------	-----------

**Cleaning**

Acid resistant graphite enamel	•
Pyrolytic self-clean	•
Removable oven door	•
Removable side ladders	•
Self-cleaning proof side ladders	•

**Controls**

Adjustable audio and display settings	•
Audio feedback	•
Automatic cooking/minute timer	•
Automatic pre-set temperatures	•
Celsius/Fahrenheit temperature	•
Delay start	•
Electronic clock	•
Electronic oven control	•
Internal Light	•
Intuitive touchscreen display	•

Multi-language display	UK English
Sabbath mode with Star K certification	•
Smart appliance	•
Soft close doors	•
Temperature sensor	•
True convection oven	•
Turned stainless capacitive touch buttons with illuminated halos	•

**Functions**

Aero Broil	•
Aero™ Bake	•
Air fry	•
Bake	•
Broil	•
Classic bake	•
Maxi Broil	•
Number of functions	14
Pastry Bake	•
Pizza bake	•
Pyrolytic self-clean	•
Roast	•
Slow cook	•
True Aero	•
Vent bake	•

**Performance**

ActiveVent™ system	•
AeroTech™ technology	•
Automatic rapid pre-heat	•

Broil power	4400 W
Temperature range	95 °F - 540 °F

**Power Requirements**

Amperage	16.6 - 19.4 A
Supply frequency	60 Hz
Supply voltage	208 - 240 V

**Product Dimensions**

Depth	23 15/16 "
Height	27 3/16 "
Width	29 15/16 "

**Safety**

ADA compliant	•
Balanced oven door	•
Catalytic venting system	•
Control panel key lock	•
CoolTouch door	•
Non-tip shelves	•
Safety thermostat	•

SKU	82579
-----	-------

The product dimensions and specifications in this page apply to the specific product and model. Under our policy of continuous improvement, these dimensions and specifications may change at any time. You should therefore check with Fisher & Paykel's Customer Care Centre to ensure this page correctly describes the model currently available. © Fisher & Paykel Appliances Ltd 2020

#### Other product downloads available at [fisherpaykel.com](https://fisherpaykel.com)

- [↓ DWG](#)
- [↓ DXF](#)
- [↓ Archicad](#)
- [↓ Installation Guide \(English, Canadian French\)](#)
- [↓ Planning Guide - Contemporary 30" Built-in Ovens and Companions \(English\)](#)
- [↓ Planning Guide - Contemporary 30" Built-in Ovens and Companions \(Canadian French\)](#)
- [↓ Planning Guide - Contemporary 30" Built-in Ovens and Companions \(Spanish\)](#)
- [↓ California Warning Proposition 65 \(English, Spanish, Canadian French, Chinese\)](#)
- [↓ Revit](#)
- [↓ Rhino](#)
- [↓ Right To Repair Declaration \(English, Canadian French\)](#)
- [↓ SketchUp](#)
- [↓ User Guide \(English\)](#)
- [↓ User Guide \(Canadian French\)](#)
- [↓ User Guide \(Spanish\)](#)

Where applicable:

All appliances use energy, and energy usage typically generates carbon emissions. **Fisher & Paykel Appliances' In-use Energy Carbon Emissions Estimate** indicates carbon emissions from a product's in-use energy. This is calculated either annually or per cycle, using the product's market-specific energy label energy consumption data multiplied by the carbon emissions factor for energy in your country or region.

Our In-use Energy Carbon Emissions Estimate is designed to assist customers in making informed purchasing decisions when comparing different Fisher & Paykel products. For example, a heat pump dryer typically has a lower In-use Energy Carbon Emissions Estimate than a vented dryer.



#### **A PEACE OF MIND SALE**

**24 Hours 7 Days a Week Customer Support**

T 1.888.936.7872 **W**[www.fisherpaykel.com](https://www.fisherpaykel.com)