

60cm Series 7 Contemporary Compact Combi-Steam Oven

Contemporary



Designed to be the cornerstone of any kitchen solution, our Combination Steam Oven is engineered for the home chef. In compact size, this oven can be placed almost anywhere.

- 18 oven functions including Steam, Sous Vide, Air Fry and Vent Bake
- With steam cooking, convection cooking, or a combination of both
- Pair with our Vacuum Seal Drawer companion product for effortless Sous Vide preparation

DIMENSIONS

Height	458 mm
Width	596 mm
Depth	565 mm

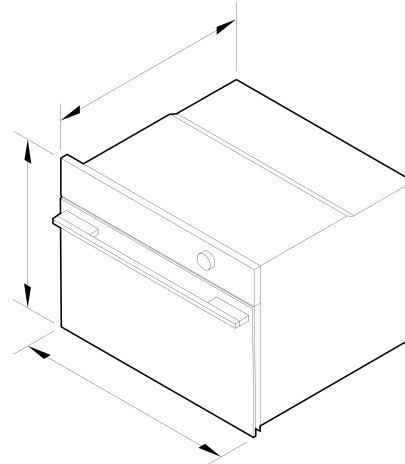

FEATURES & BENEFITS

Combination Cooking

Give every ingredient the respect it deserves with combination steam cooking. Using a fusion of dry convection heat with variable amounts of steam, you can easily retain the delicate texture of ingredients like salmon and snapper, the vitamins and minerals of greens, or the depth of flavour of a perfect cut of meat.

Mastery Of Temperature

Elevate your meals with the precise temperature and humidity control of steam cooking. Steam cooking has a gentler heat transfer into the food, so you get nutritious and delicious results that are moist and tender on the inside, crisp and flaky on the outside, all with minimal effort.

Preserve Flavour And Nutrients

Cooking with steam creates dishes that are full of flavour, while preserving all the vitamins, minerals and textures of delicate ingredients, like fish and seafood. With five steam-only cooking functions, including Sous vide, Steam and Steam Proof, you can use steam to create healthier dishes that get the best out of each component on the plate.

Multi-Function Flexibility

A truly multiple function oven where both steam-only and convection-only cooking mediums can stand on their own merits. You have the freedom to choose - whether it's dry heat or moist heat, or a combination of the two - each delivering different cooking results. Purchase our Wireless Temperature Sensor accessory and precisely monitor cooking in real time (accessory sold separately).

Design Freedom

This Contemporary style oven has a stylish black finish with stainless steel contrasts, designed to help you achieve a kitchen aesthetic that suits your design style. Pair with a Vacuum Seal Drawer for the ultimate kitchen solution.

Sized To Suit

This compact 60cm Steam Oven can be placed almost anywhere. All Companion products can be installed at a convenient height to suit your kitchen design and preference.

SPECIFICATIONS

Accessories (included)

Chromed shelf runners

Descale solution	2 sachets, Part 580925
Flat brushed baking tray	1
Grill rack	1 set
Large steam dish	1
Perforated large steam dish	1
Roasting dish	1
Step down wire shelf	1
Telescopic sliding runners	1 set
Wire shelf	1

Capacity

Shelf positions	4
Total capacity	55 L
Usable capacity	45 L
Water tank capacity	1.5L

Cleaning

Acid resistant graphite enamel	•
Descale cycle	•
Drying cycle	•
Removable oven door	•
Removable oven door inner glass	•
Removable side ladders	•
Removable water tank	•
Steam clean (oven)	•

Connected Features

Cyber security updates until	02 / 02 / 2029
------------------------------	-----------------------

Controls

Adjustable audio and display settings	•
Audio feedback	•
Automatic cooking/minute timer	•
Automatic pre-set temperatures	•
Delay start	•
Electronic clock	•
Electronic oven control	•
Guided cooking by food types	•
Internal Light	•
Multi-language display	•
Sabbath mode with Mehadrin certification	•
Smart appliance	•
Soft close doors	•
True convection oven	•
Turned stainless steel dials with illuminated halos	•
Wireless temperature sensor compatible	•

UK English

Functions

Air fry	•
Bake	•
Fan bake	•
Fan forced	•
Fan forced + High steam	•
Fan forced + Low steam	•
Fan forced + Medium steam	•
Fan grill	•
Grill	•
Number of functions	18
Pizza bake	•

Roast	•
Slow cook	•
Sous vide	•
Steam	•
Steam clean (oven)	•
Steam defrost	•
Steam proof	•
Vent bake	•

Performance

ActiveVent™ system	•
AeroTech™ technology	•
Automatic rapid pre-heat	•
Grill power	3000 W
SteamTechnology	•
Temperature range	35°C - 230°C
Whisper Quiet Cooking	•

Power requirements

Amperage	15 A
Supply frequency	50 Hz
Supply voltage	220-240VAC V

Product dimensions

Depth	565 mm
Height	458 mm
Width	596 mm

Safety

- Balanced oven door
- Control panel key lock
- CoolTouch door
- Non-tip shelves
- Safety thermostat

All appliances use energy, and energy usage typically generates carbon emissions. **Fisher & Paykel Appliances' In-use Energy Carbon Emissions Estimate** indicates carbon emissions from a product's in-use energy. This is calculated either annually or per cycle, using the product's market-specific energy label energy consumption data multiplied by the carbon emissions factor for energy in your country or region.

Our In-use Energy Carbon Emissions Estimate is designed to assist customers in making informed purchasing decisions when comparing different Fisher & Paykel products. For example, a heat pump dryer typically has a lower In-use Energy Carbon Emissions Estimate than a vented dryer.

SKU 82636

The product dimensions and specifications in this page apply to the specific product and model. Under our policy of continuous improvement, these dimensions and specifications may change at any time. You should therefore check with Fisher & Paykel's Customer Care Centre to ensure this page correctly describes the model currently available. © Fisher & Paykel Appliances Ltd 2020



A PEACE OF MIND SALE
24 Hours 7 Days a Week Customer Support

T 1300 650 590 [Wwww.fisherpaykel.com](http://www.fisherpaykel.com)

Other product downloads available at fisherpaykel.com

- [↓](#) DWG
- [↓](#) DXF
- [↓](#) Installation Guide (English)
- [↓](#) Revit
- [↓](#) Rhino
- [↓](#) SketchUp
- [↓](#) User Guide (English)

Where applicable: