

Wall Rangehood, 90cm, Box Chimney with External Motor

Series 7 | Contemporary

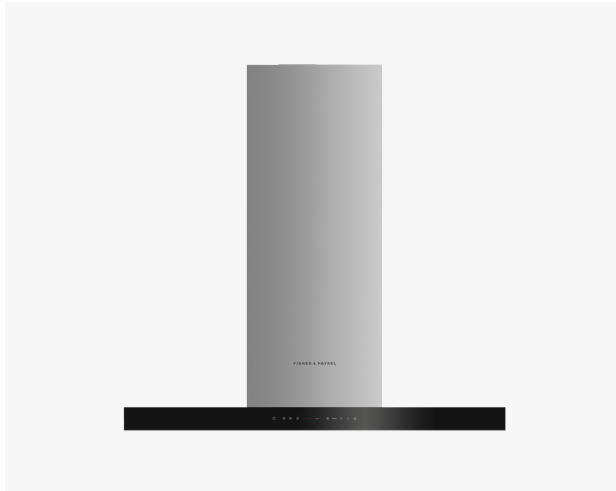

This wall chimney rangehood has an externally installed inline motor to deliver near silent yet powerful extraction of steam, grease and cooking odours.

- With three fan speeds plus a boost function, select the perfect extraction rate for your cooking
- Perimeter extraction for efficient removal of steam and odours
- Powerful maximum air movement of 1200m³/hr
- Wi-Fi enabled for notifications through the SmartHQ™ app

DIMENSIONS

Height	635-1035mm
Width	898mm
Depth	500mm

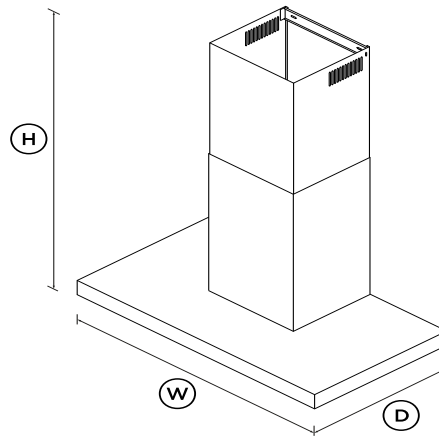

FEATURES & BENEFITS

Near silent extraction

The powerful external motor is installed outside the home to deliver near silent extraction of cooking odours and steam from the kitchen.

Seamless integration

Designed to match our Contemporary style appliances, this wall chimney rangehood features sleek black glass and stainless steel styling to complement any kitchen design.

Effective extraction

Featuring perimeter extraction, three fan speeds and a boost function, this rangehood provides powerful extraction to quickly

remove odours and steam. Odours can linger in the kitchen well after cooking is finished so the timer keeps the hood working for up to 15 minutes before automatically turning off.

Full surface lighting

Energy-efficient, dimmable LED lights provide superb illumination of the entire cooking surface.

Easy cleaning

Designed for simple removal, the filters are easy to clean and dishwasher safe, while the glass and stainless steel finish is easily wiped clean. The SmartHQ™ app will notify you when to clean the filters to ensure you get the best performance out of your rangehood.

Considered efficiency

The right amount of air is extracted to effectively remove cooking odours with reduced effect on your heating or air conditioning.

SPECIFICATIONS

Fan ratings

Maximum air movement	1200m ³ /hr
----------------------	------------------------

Installation and cleaning

Dishwasher safe filters	3
Ducted	Top extraction
Stainless steel filter cover	•
Two piece height adjustable	•

Performance

Extraction type	Surface
Fan speeds	3
Filter type	Mesh
Number of filters	3

Power requirements

Supply frequency	50Hz
Supply voltage	220-240V

Product dimensions

Depth	500mm
Height	635-1035mm
Width	898mm

Product information

Control type	Capacitive touch
--------------	------------------

Ventilation features

Auto-off/Run-on timer	•
Dimmable lights	•
Filter cleaning alert	•
Light type	LED strip
Timer function	•
Wi-Fi connectivity	•

Warranty

Parts and labour	2 years
------------------	---------

SKU	50198
-----	-------

specifications may change at any time. You should therefore check with Fisher & Paykel's Customer Care Centre to ensure this page correctly describes the model currently available. Fisher & Paykel Appliances Ltd 2020

Where applicable:

All appliances use energy, and energy usage typically generates carbon emissions. **Fisher & Paykel Appliances' In-use Energy Carbon Emissions Estimate** indicates carbon emissions from a product's in-use energy. This is calculated either annually or per cycle, using the product's market-specific energy label energy consumption data multiplied by the carbon emissions factor for energy in your country or region.

Our In-use Energy Carbon Emissions Estimate is designed to assist customers in making informed purchasing decisions when comparing different Fisher & Paykel products. For example, a heat pump dryer typically has a lower In-use Energy Carbon Emissions Estimate than a vented dryer.

**A PEACE OF MIND SALE****24 Hours 7 Days a Week Customer Support**T 1300 650 590 **W** www.fisherpaykel.com

The product dimensions and specifications in this page apply to the specific product and model. Under our policy of continuous improvement, these dimensions and