

# 30" Series 9 Wall Range Hood

Width	29 7/8 "
Depth	25 1/16 "

Our Range Hood filters have been improved to capture more cooking steam, odors and grease. They're easy to remove and clean - simply put them in your DishDrawer™ dishwasher.

## SPECIFICATIONS

Professional

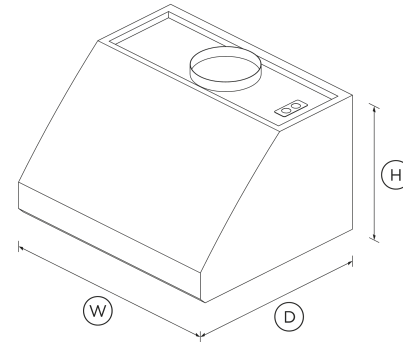
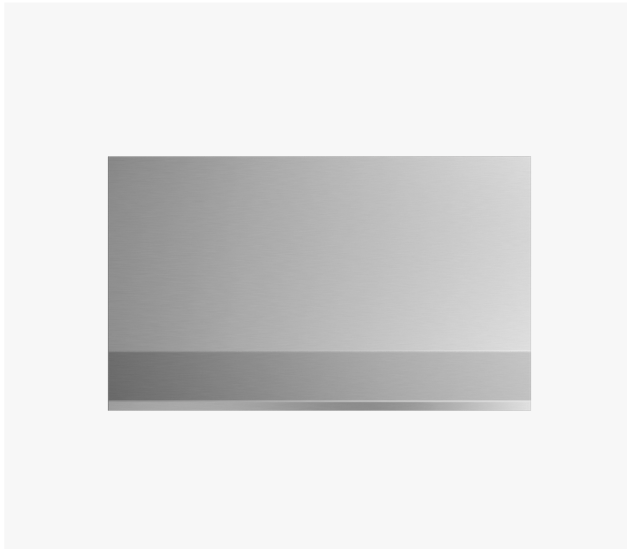

## FEATURES & BENEFITS

### Simple Design

The new stainless steel range hood is tough and hardworking with a style and simplicity to fit seamlessly into your kitchen.

### Edge To Edge Filters

We've improved our filters to capture and extract more cooking steam, odors and grease.

### Precise Control

The Professional Range Hood has been designed to give you better control with sturdy stainless steel dials to set your desired fan speed and light level.

### Effective Extraction

### Accessories (sold separately)

12" Vertical duct cover	HCC3012
6" Vertical duct cover	HCC3006
Light bulb	104176P

### Fan ratings

Maximum speed sound rating	10 sones
Speed 1 sound rating	2 sones

### Installation and cleaning

Air outlet size	8" "
Dishwasher safe filters	2
Ducted	Top extraction
Recirculation	Ducted only

### Performance

Extraction type	Surface
Fan speeds	4
Filter type	Stainless Steel Baffle

### Power Requirements

Striking design that pairs well with any appliances in our Professional range. Fast, efficient extraction of steam and odors.

- With four fan speeds, select the perfect extraction rate for your cooking
- Dishwasher-safe filters that are easy to remove and clean
- Powerful 600CFM maximum airflow

## DIMENSIONS

Height	18 "
--------	------

Lighting power	<b>50 W</b>
Motor power	<b>455 W</b>
Supply voltage	<b>120 V</b>
Total Power	<b>555 W</b>

- [↓](#) Rhino
- [↓](#) Rhino - Duct Cover
- [↓](#) Right To Repair Declaration (English, Canadian French)
- [↓](#) SketchUp
- [↓](#) SketchUp - Duct Cover
- [↓](#) Installation & User Guide (English, Canadian French)

#### Product Dimensions

Depth	<b>25 1/16 "</b>
Height	<b>18 "</b>
Width	<b>29 7/8 "</b>

#### Where applicable:

All appliances use energy, and energy usage typically generates carbon emissions. **Fisher & Paykel Appliances' In-use Energy Carbon Emissions Estimate** indicates carbon emissions from a product's in-use energy. This is calculated either annually or per cycle, using the product's market-specific energy label energy consumption data multiplied by the carbon emissions factor for energy in your country or region.

Our In-use Energy Carbon Emissions Estimate is designed to assist customers in making informed purchasing decisions when comparing different Fisher & Paykel products. For example, a heat pump dryer typically has a lower In-use Energy Carbon Emissions Estimate than a vented dryer.

#### Ventilation features

Dimmable lights	<b>.</b>
Light type	<b>Halogen</b>

SKU 50260



**A PEACE OF MIND SALE**  
**24 Hours 7 Days a Week Customer Support**  
 T 1.888.936.7872 W [www.fisherpaykel.com](http://www.fisherpaykel.com)

The product dimensions and specifications in this page apply to the specific product and model. Under our policy of continuous improvement, these dimensions and specifications may change at any time. You should therefore check with Fisher & Paykel's Customer Care Centre to ensure this page correctly describes the model currently available. © Fisher & Paykel Appliances Ltd 2020

#### Other product downloads available at [fisherpaykel.com](http://fisherpaykel.com)

- [↓](#) Archicad
- [↓](#) Archicad - 12" Duct Cover
- [↓](#) Archicad - 6" Duct Cover
- [↓](#) Revit