

# 30" Series 9 Professional Compact Combi-Steam Oven

Professional



Reduce the need for oils and fats with steam cooking. The Combination Steam Oven's compact size is designed to pair with a Professional-style warming drawer underneath, creating the perfect interpretation of the bold design seen in a commercial kitchen.

- 1.3 cu ft total capacity
- Cooking flexibility with nine oven functions, including five Steam functions, Broil and Convection
- Steam cooking allows you to cook a food in its own juices, to retain nutrients and flavor

- Designed to match aesthetically with Professional-style companion products such as warming drawers, for flexible cooking configurations

## DIMENSIONS

Height	18 1/2 "
Width	29 13/16 "
Depth	20 13/16 "

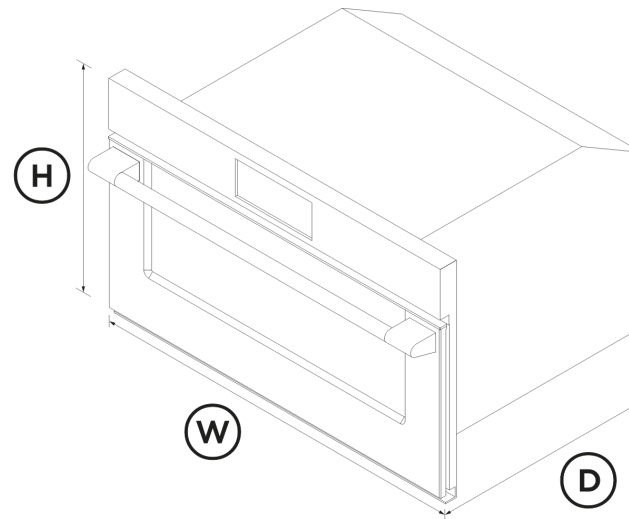

## FEATURES & BENEFITS

### Sized To Suit

This compact 30" Steam Oven can be placed almost anywhere. It can be installed at a convenient height to suit your kitchen design and preference, with room for a drawer underneath. The bold stainless steel styling is designed to match our Professional-style cooking products.

### Simple To Use

An easy to use, intuitive display shows the time and provides useful information about functions along with a refill alert.

### Easy Cleaning

Cleaning and care of the Steam Oven is simple. After each use, just wipe the smooth stainless steel interior with a dry cloth.

### Safe And Sound

The CoolTouch door is safe to touch from the outside, protecting your hands and the surrounding cabinetry.

### Easy Installation

Plug in and cook straight away. The Steam Oven is easy to install, with no plumbing needed.

### Healthy Eating

The Steam Oven allows you to cook food in its own juices to retain nutrients and flavor. With nine oven modes, it doesn't just steam, but also has Broil and Fan functions.

## SPECIFICATIONS

### Accessories (included)

Baking pan	1
Perforated large steam dish	1
Wire shelf	1
Wired temperature sensor	1

### Capacity

Shelf positions	3
Total capacity	1.3 cu ft

**Cleaning**

- Easy clean stainless steel interior
- Removable water tank
- Steam clean (oven)

**Controls**

- Audio feedback
- Automatic cooking/minute timer
- Celsius/Fahrenheit temperature
- Delay start
- Electronic clock
- Electronic oven control
- Guided cooking by food type and recipes
- Internal Light
- Intuitive touchscreen display
- Temperature sensor

**Functions**

- Broil
- Convection Broil
- Number of functions **9**
- Ring + broil
- Steam + ring
- Steam 100 (100°C / 210°F)
- Steam 130 (130°C / 265°F)
- Steam assist
- Steam clean (oven)
- True convection

**Performance**

- Broil power **1500 W**
- SteamTechnology

**Power Requirements**

- Amperage **15 A**
- Supply frequency **60 Hz**
- Supply voltage **208 - 240 V**

**Product Dimensions**

- Depth **20 13/16 "**
- Height **18 1/2 "**
- Width **29 13/16 "**

**Safety**

- ADA compliant
- Control panel key lock
- CoolTouch door
- Safety thermostat

SKU 81930

The product dimensions and specifications in this page apply to the specific product and model. Under our policy of continuous improvement, these dimensions and specifications may change at any time. You should therefore check with Fisher & Paykel's Customer Care Centre to ensure this page correctly describes the model currently available. © Fisher & Paykel Appliances Ltd 2020

**Other product downloads available at fisherpaykel.com**

- [↓ DWG](#)
- [↓ DXF](#)
- [↓ Archicad](#)
- [↓ Data Sheet \(English\)](#)
- [↓ Installation Guide \(English\)](#)
- [↓ Installation Guide \(Canadian French\)](#)
- [↓ Revit](#)
- [↓ Rhino](#)
- [↓ Right To Repair Declaration \(English, Canadian French\)](#)
- [↓ SketchUp](#)
- [↓ User Guide \(Canadian French\)](#)

**Where applicable:**

All appliances use energy, and energy usage typically generates carbon emissions. **Fisher & Paykel Appliances' In-use Energy Carbon Emissions Estimate** indicates carbon emissions from a product's in-use energy. This is calculated either annually or per cycle, using the product's market-specific energy label energy consumption data multiplied by the carbon emissions factor for energy in your country or region.

Our In-use Energy Carbon Emissions Estimate is designed to assist customers in making informed purchasing decisions when comparing different Fisher & Paykel products. For example, a heat pump dryer typically has a lower In-use Energy Carbon Emissions Estimate than a vented dryer.



**A PEACE OF MIND SALE**  
**24 Hours 7 Days a Week Customer Support**

T 1.888.936.7872 W [www.fisherpaykel.com](http://www.fisherpaykel.com)