

FABRIC CARE

PLANNING GUIDE

Series 5 Front Loader Washer | WH8060J5 | WH9060J5

Series 5 Heat Pump Dryer | DH8060J5 | DH9060J5

Stacking Kit with Tray | ASKS60W5

FISHER & PAYKEL

INTRODUCTION

This comprehensive planning guide provides you with the framework and tools to achieve your desired design outcome with Fisher & Paykel appliances. In this guide, you will find a range of conceptual, detailed, and dimensional product information to bring your ideas to life and create spaces that truly reflect your vision.

SUPPORT

For additional design planning and installation support please contact the Fisher & Paykel design support team.
designsupport@fisherpaykel.com

NOTES

The models shown in this Planning Guide may not be available in all markets and are subject to change at any time. For the latest version of this document, please visit our website at fisherpaykel.com. Product specifications may vary from those shown.

This Planning Guide is not intended to be used as installation guidance for any product. Detailed installation instructions are available on our website.

CONTENTS

CONCEPT DESIGN		PAGE	DEVELOPED AND DETAILED DESIGN		PAGE	DEVELOPED AND DETAILED DESIGN		PAGE
PRODUCT OVERVIEW			DATA SHEETS			SERVICES		
Product Overview		4	WH8060J5, WH9060J5		11	Front load washers		17
Product Configurations		5	DH8060J5, DH9060J5		12	Front load dryers		18
			ASKS60W5		13	Side by side installation		19
SPECIFICATION GUIDE			CONFIGURATIONS					
Fabric Care - All Models		7	Stacked		15	Stacked installation		20
Front Loader Washer WH8060J5, WH9060J5		8						
Heat Pump Dryer DH8060J5, DH9060J5		9						

PRODUCT OVERVIEW

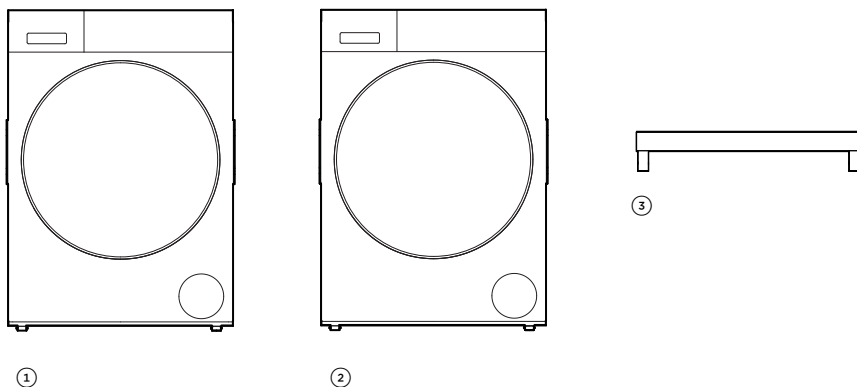

PRODUCT OVERVIEW

Series 5 Front Loader Washers

①	WH8060J5	8kg Series 5 Front Loader Washer	White
	WH9060J5	9kg Series 5 Front Loader Washer	White

Series 5 Front Heat Pump Dryers

②	DH8060J5	8kg Series 5 Heat Pump Dryer	White
	DH9060J5	9kg Series 5 Heat Pump Dryer	White

ACCESSORIES OVERVIEW

③	ASKS60W5	Stacking Kit with Tray	White
---	-----------------	------------------------	-------

The models shown in this Planning Guide may not be available in all markets and are subject to change at any time. For the latest version of this document, please visit our website at fisherpaykel.com. Product specifications may vary from those shown. The Planning Guide is not intended to be used as installation guidance for any product. Detailed installation instructions are available on our website.

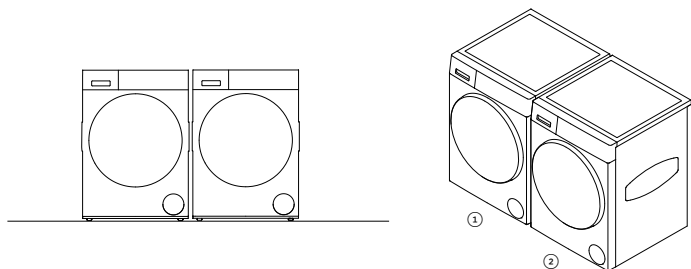

SIDE BY SIDE

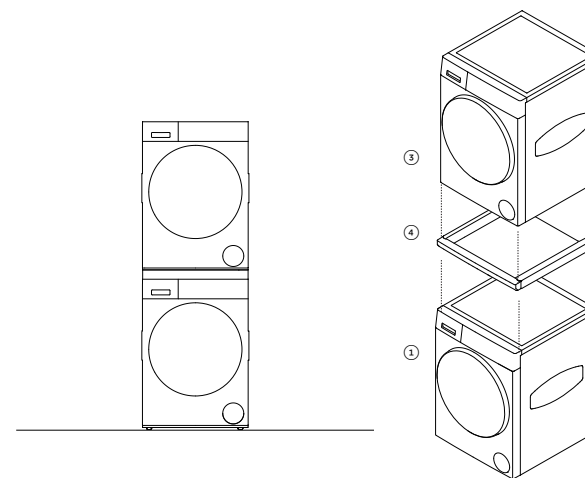

STACKED

	MODEL CODE	FINISH	PRODUCT DESCRIPTION	HINGE LOCATION
①	WH8060J5	White	Front Loader Washer	Left Hand
	WH9060J5	White	Front Loader Washer	Left Hand
②	DH8060J5	White	Heat Pump Dryer	Right Hand (Reversible hinge)
	DH9060J5	White	Heat Pump Dryer	Right Hand (Reversible hinge)
③	DH8060J5	White	Heat Pump Dryer	Left Hand Hinge (Reversible hinge)
	DH9060J5	White	Heat Pump Dryer	Left Hand Hinge (Reversible hinge)
④	ASKS60W5 (white)	White	Stacking Kit with Tray	-

* Other product configuration possible - Stacking Kit (ASKS60ZB5) cannot be installed side by side due to hinge clashes.

The models shown in this Planning Guide may not be available in all markets and are subject to change at any time. For the latest version of this document, please visit our website at fisherpaykel.com. Product specifications may vary from those shown. The Planning Guide is not intended to be used as installation guidance for any product. Detailed installation instructions are available on our website.

SPECIFICATION GUIDE



WH9060J5, DH9060J5

OVERVIEW

Our Fabric Care Solutions combine sleek design and refined materials with advanced technology to elevate the laundry. Front Loader Washing Machines powered by SmartDrive™ deliver quieter operation, while Heat Pump Dryers with intelligent compressor control and moisture sensing provide efficient, gentle drying.

Designed as a true pair, their aligned proportions and pared-back interfaces bring a cohesive, considered aesthetic to the laundry space.

FEATURES

- ① The sleek modern design, large door, and carefully selected materials elevate our Fabric Care Solutions within the laundry. Thoughtfully crafted to integrate with surrounding finishes, they transform the laundry into a considered extension of the home's design.
- ② Front Loader Washing Machines and Heat Pump Dryers are designed as a true pair, with aligned proportions, finishes, and controls. Install them side-by-side or stacked with the Stacking Kit and Storage Plinth for better ergonomics.
- ③ Interfaces and detailing are paired back to achieve a clean, minimal presentation. This reduction in visual noise helps appliances blend into design-led environments, supporting calm and considered interiors.
- ④ Powered by SmartDrive™ technology, Front Loader Washing Machines deliver quiet operation with few moving parts. This makes them well suited to placement in open-plan areas or wardrobes, where a low-noise environment is important.

⑤ Heat Pump Dryer technology with precise temperature control and moisture sensing delivers efficient yet gentle drying. Intelligent compressor technology adjusts drying temperatures to suit each fibre's durability, while specialised tumble patterns ensure optimal care and cycle times.

⑥ The LED provides a clear, modern interface to guide users through cycle selection with ease. This intuitive control makes it simple to care for fibres from Cotton and Polyester to Woolmark Black certified Wool.

⑦ Steam Refresh and Sanitise reduce reliance on dry-cleaning by refreshing garments quickly and safely at home.

⑧ Auto-Dosing protects fibres and prevents waste by dispensing the perfect amount of detergent and softer for every load. With two reservoirs, one for detergent and the other for softener, which can also hold extra detergent if required.

⑨ Designed to reduce running costs and environmental impact with highly efficient energy and water ratings, delivering an effective and sustainable fabric care routine.

⑩ SmartHQ™ compatibility enables remote monitoring, notifications when cycles are complete, and software updates when new cycles and feature enhancements are available.

SPECIFICATIONS

Model Number

WH8060J5	8kg Front Loader Washer, White
WH9060J5	9kg Front Loader Washer, White

Product Dimensions

H 850mm W 602mm D 593mm

Electrical

Supply	220-240 V, 50 Hz
Service	10 A
Connection	3-prong grounding-type

Plumbing

Supply	Hose set provided
Service	Max. 1MPa (150psi); Min. 50KPa (7psi); Min. 6 litres/min

PRODUCT DIMENSIONS

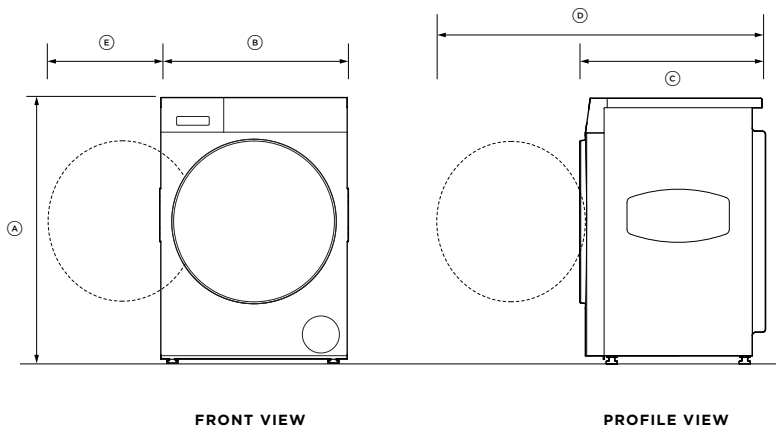

CAVITY DIMENSIONS

	mm		mm
(A) Overall height	850	(A) Minimum height	865
Height of adjustable mounted feet	max +10	(B) Minimum width	622
(B) Overall width including chassis form	602	(C) Minimum depth	623
Overall width front chassis	592	Minimum visual gap to adjacent cabinetry and product*	15
(C) Overall depth*	593		
(D) Depth with the door open	1167		
(E) Door clearance to adjacent wall	267		

*Includes door when closed

*Applies to sides and top

The models shown in this Planning Guide may not be available in all markets and are subject to change at any time. For the latest version of this document, please visit our website at fisherpaykel.com. Product specifications may vary from those shown. The Planning Guide is not intended to be used as installation guidance for any product. Detailed installation instructions are available on our website.

SPECIFICATIONS

Model Number

DH8060J5	8kg Heat Pump Dryer, White
DH9060J5	9kg Heat Pump Dryer, White

Product Dimensions

H 850mm **W** 602mm **D** 682mm

Electrical

Supply	220-240 V, 50 Hz
Service	10 A
Connection	3-prong grounding-type

Plumbing

Supply	Hose set provided
Service	Max. 1MPa (150psi); Min. 50KPa (7psi); Min 6 litres/min

PRODUCT DIMENSIONS

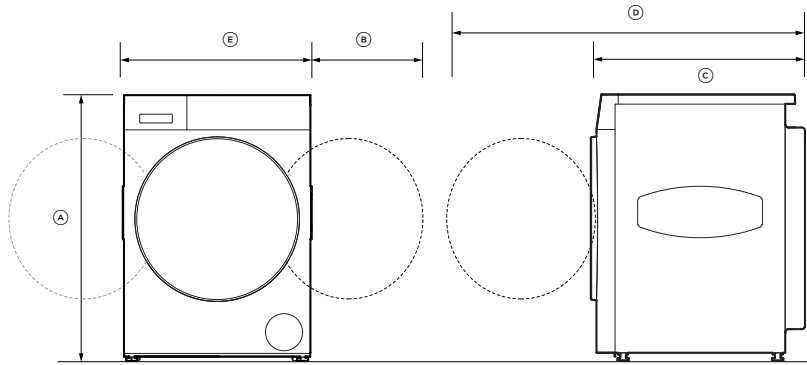

FRONT VIEW

PROFILE VIEW

ISOMETRIC VIEW

	mm		mm
A Overall height	850	A Minimum height	865
Height of adjustable mounted feet	min -5 max +5	B Minimum width	622
B Overall width including chassis form	602	C Minimum depth	688
Overall width front panel	592	Minimum visual gap to adjacent cabinetry and product*	15
C Overall depth*	682	*Applies to sides and top	
D Depth with the door open**	1167		
E Door clearance to adjacent wall	267		

*Includes door when closed
**Dryer door hinge is reversible

The models shown in this Planning Guide may not be available in all markets and are subject to change at any time. For the latest version of this document, please visit our website at fisherpaykel.com. Product specifications may vary from those shown. The Planning Guide is not intended to be used as installation guidance for any product. Detailed installation instructions are available on our website.

DATA SHEETS

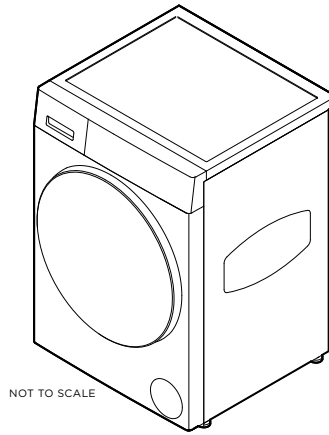
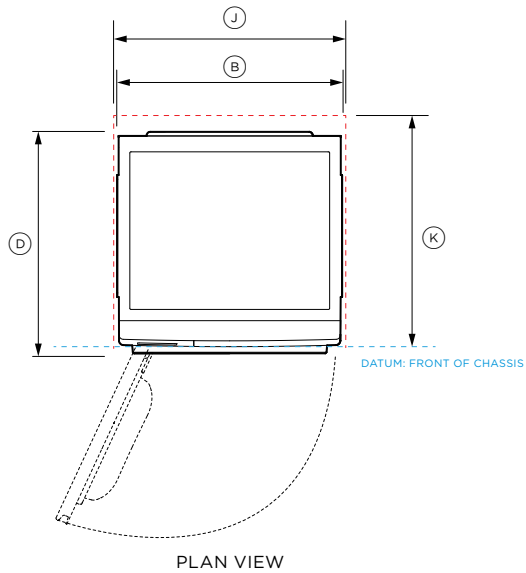

ISOMETRIC VIEW

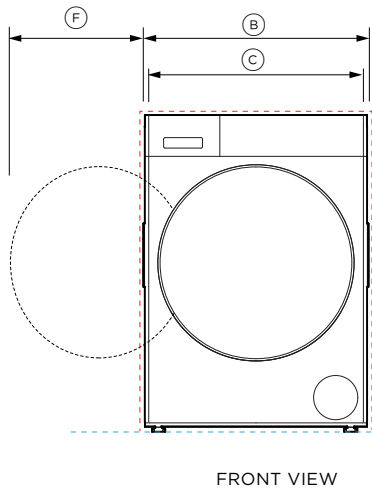

FRONT VIEW

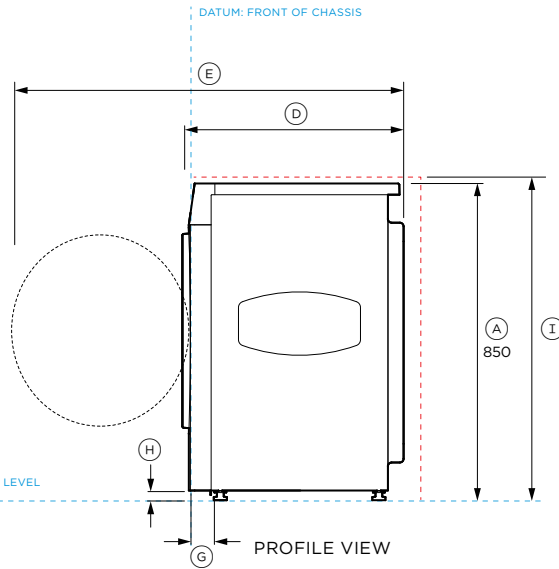

PROFILE VIEW



Model no:

WH8060J5, WH9060J5

Product Dimensions

	mm
Ⓐ Overall height	850
Ⓑ Overall width including chassis form	602
Overall width excluding chassis form	595
Ⓒ Overall width front panel	592
Ⓓ Overall depth	593
Ⓔ Depth with the door open	1167
Ⓕ Door clearance to adjacent wall	min 267
Ⓖ Overall depth of finished front panel	55
Ⓗ Height of adjustable mounted feet	min -5 max +10

Cavity Dimensions: Standard Installation

	mm
Ⓘ Minimum height of cavity*	865
Ⓛ Minimum width of cavity	622
Ⓚ Minimum overall cavity depth	623
• Flush with front panel of the chassis	
Minimum gap clearance to adjacent product or cabinetry**	10
Minimum visual gap to adjacent cabinetry and product	15

* Depends on feet adjustment

** Applies to sides and top

----- INDICATES CABINETRY / PRODUCT DATUM

----- INDICATES CABINETRY CLEARANCES

----- INDICATES CUTOUT

IMPORTANT NOTE: Throughout this guide, dimensions may vary by ±2mm (1/16"). Please read the installation manual for detailed information on installing the product. For full installation instructions & specifications visit fisherpaykel.com

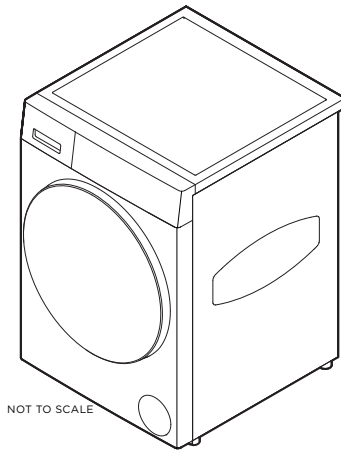
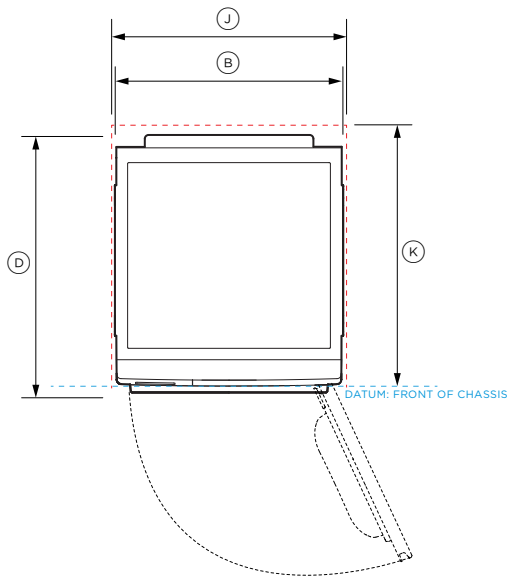

ISOMETRIC VIEW

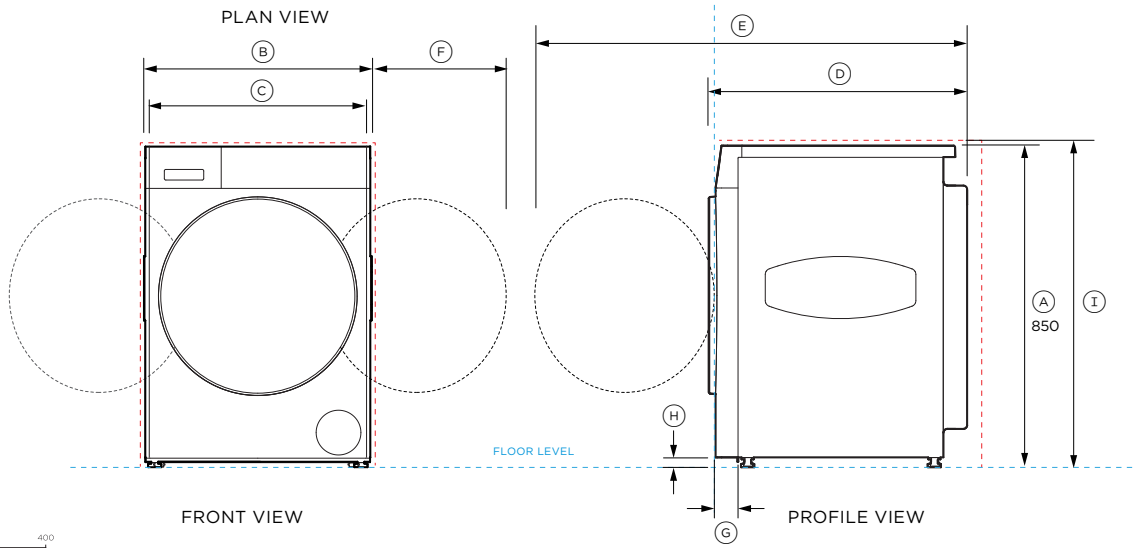

Model no:

DH8060J5, DH9060J5

Product Dimensions

	mm
Ⓐ Overall height	850
Ⓑ Overall width including chassis form	602
Overall width excluding chassis form	595
Ⓒ Overall width front panel	592
Ⓓ Overall depth	682
Ⓔ Depth with the door open***	1167
Ⓕ Door clearance to adjacent wall	min 267
Ⓖ Overall depth of finished front panel	55
Ⓜ Height of adjustable mounted feet	min -5 max +5

Cavity Dimensions: Standard Installation

	mm
Ⓣ Minimum height of cavity*	865
Ⓝ Minimum width	622
Ⓚ Minimum overall cavity depth	688
• Flush with front panel of the chassis	688
Minimum gap clearance to adjacent product or cabinetry**	10
Minimum visual gap to adjacent cabinetry and product	15

* Depends on feet adjustment

** Applies to sides and top

*** Dryer door hinge is reversible

----- INDICATES CABINETRY / PRODUCT DATUM

----- INDICATES CABINETRY CLEARANCES

----- INDICATES CUTOUT

IMPORTANT NOTE: Throughout this guide, dimensions may vary by ±2mm (1/16"). Please read the installation manual for detailed information on installing the product. For full installation instructions & specifications visit fisherpaykel.com

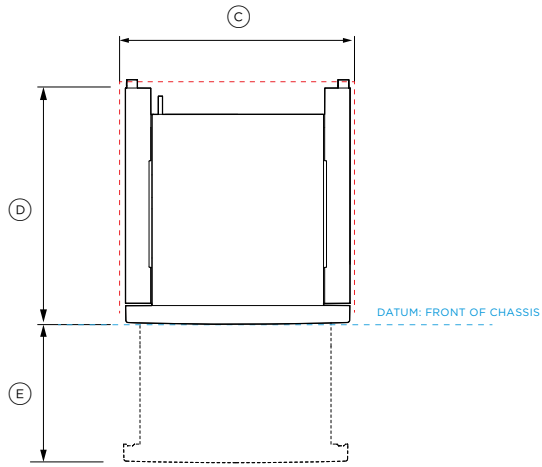

PLAN VIEW

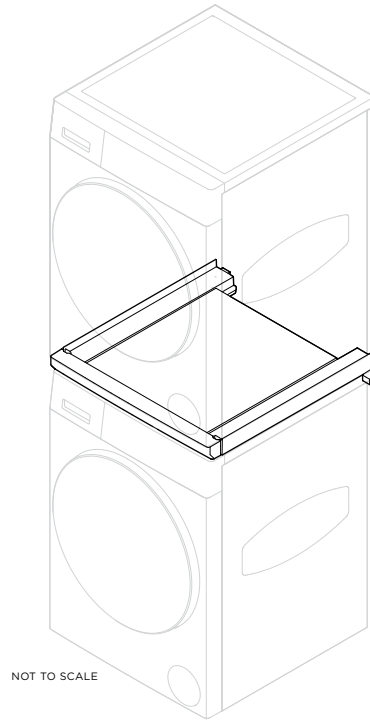

NOT TO SCALE

ISOMETRIC VIEW

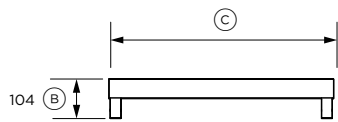

FRONT VIEW

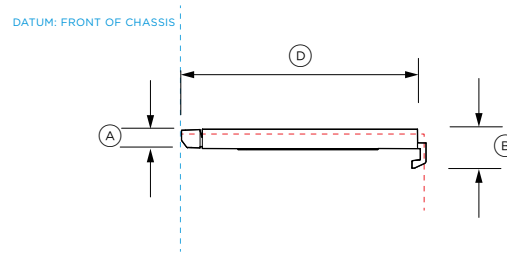

PROFILE VIEW



Model no:

Stacking kit ASKS60W5, ASKS60G5

Product Dimensions

	mm
Ⓐ Overall height	104
Ⓑ Shelf height	52
Ⓒ Overall width	595
Ⓓ Overall depth	648
Ⓔ Tray extension	405

----- INDICATES CABINERY / PRODUCT DATUM
 - - - - - INDICATES CABINERY CLEARANCES
 - · - · - INDICATES CUTOUT

IMPORTANT NOTE: Throughout this guide, dimensions may vary by ±2mm (1/16"). Please read the installation manual for detailed information on installing the product. For full installation instructions & specifications visit fisherpaykel.com

CONFIGURATIONS

Washing Machine

WH8060J5* White

WH9060J5* White

Heat Pump Dryer

DH8060J5** White

DH8060J5** White

Stacking Kit with Tray

ASKS60W5 White

*Left Hand Hinge

**Left Hand Hinge (door hinge is reversible)

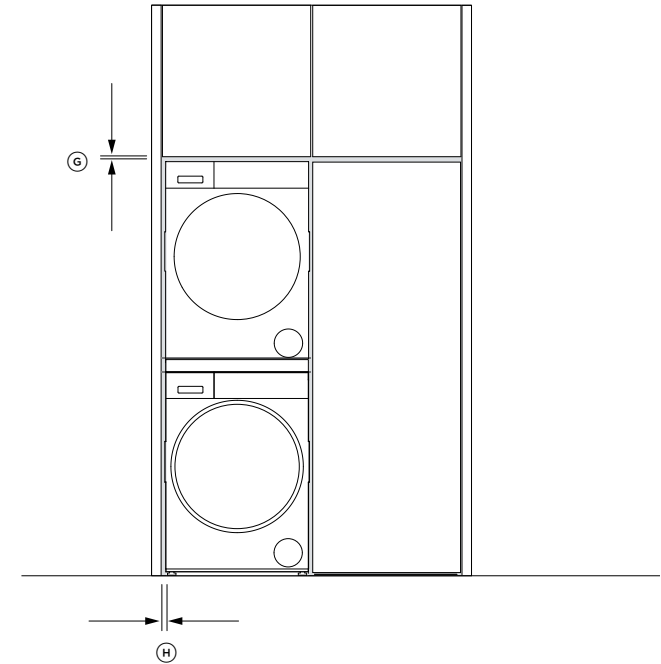
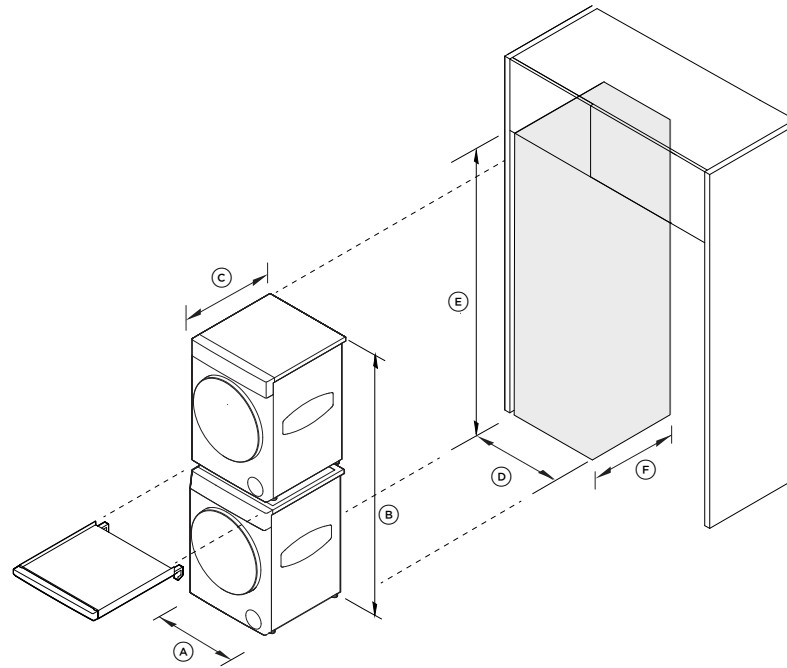

PRODUCT DIMENSIONS	
	mm
Ⓐ Overall products width Washer, Dryer and Stacking Kit	602
Ⓑ Overall product height Washer, Dryer and Stacking Kit	1720
Ⓒ Overall product depth Washer, Dryer and Stacking Kit	682

CAVITY DIMENSIONS	
	mm
Ⓓ Overall cavity width	622
Ⓔ Overall cavity height	1740
Ⓕ Overall cavity depth	688

GAPS	
	mm
Ⓖ Minimum top gap clearance	10
Minimum visual top gap	15
Ⓖ Minimum vertical gap clearance visual gap	10
Minimum visual vertical gap	15

* Washer and Dryer width exclude the chassis form

The models shown in this Planning Guide may not be available in all markets and are subject to change at any time. For the latest version of this document, please visit our website at fisherpaykel.com. Product specifications may vary from those shown. The Planning Guide is not intended to be used as installation guidance for any product. Detailed installation instructions are available on our website.

SERVICES

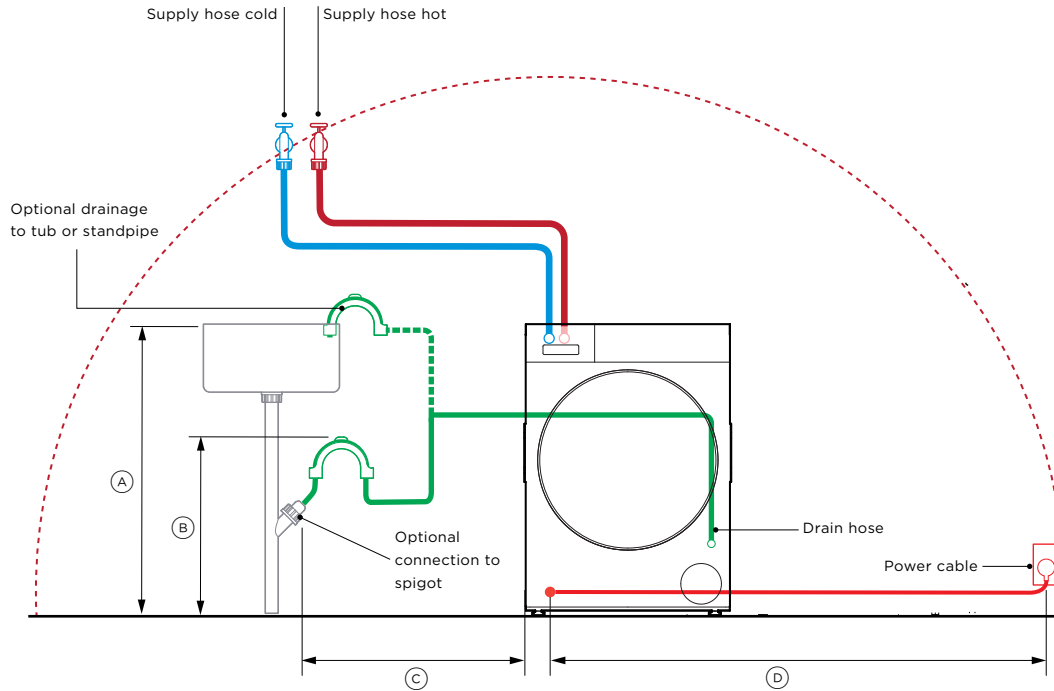

Model nos:

Front Loader Washing Machine - WH8060J5, WH9060J5

Product Dimensions

	mm
Ⓐ Maximum standpipe or tub height	1000
With storage plinth	1200
Ⓑ Minimum standpipe or tub height	600
With storage plinth	800
Ⓒ Maximum distance to standpipe when located on the left	400
Maximum distance to standpipe when located on the right	1000
Ⓓ Maximum power cord length to power outlet	1400

Specifications

Electrical

Supply	220 - 240 VAC, 50 Hz
Service	10 Amps
Outlet	3-prong grounding - type

Plumbing

Supply	Hose set provided
Pressure	Max. 1MPa (150psi) Min. 50KPa (7psi); Min 6 litres/min

NOTES:

Connections may be located in an adjacent cabinet to either side of the washer. Ensure power will remain accessible following install to allow access for any future product maintenance.

A washer and dryer without separate cold-water inlets shall be no more than 900mm apart in order to use steam cycles on the dryer.

Multiple product installation requires the design of water and power outlets according to local regulations.

----- INDICATES CABINETRY / PRODUCT DATUM

----- INDICATES CABINETRY CLEARANCES

----- INDICATES CUTOUT

IMPORTANT NOTE: Throughout this guide, dimensions may vary by ±2mm (1/16"). Please read the installation manual for detailed information on installing the product. For full installation instructions & specifications visit fisherpaykel.com

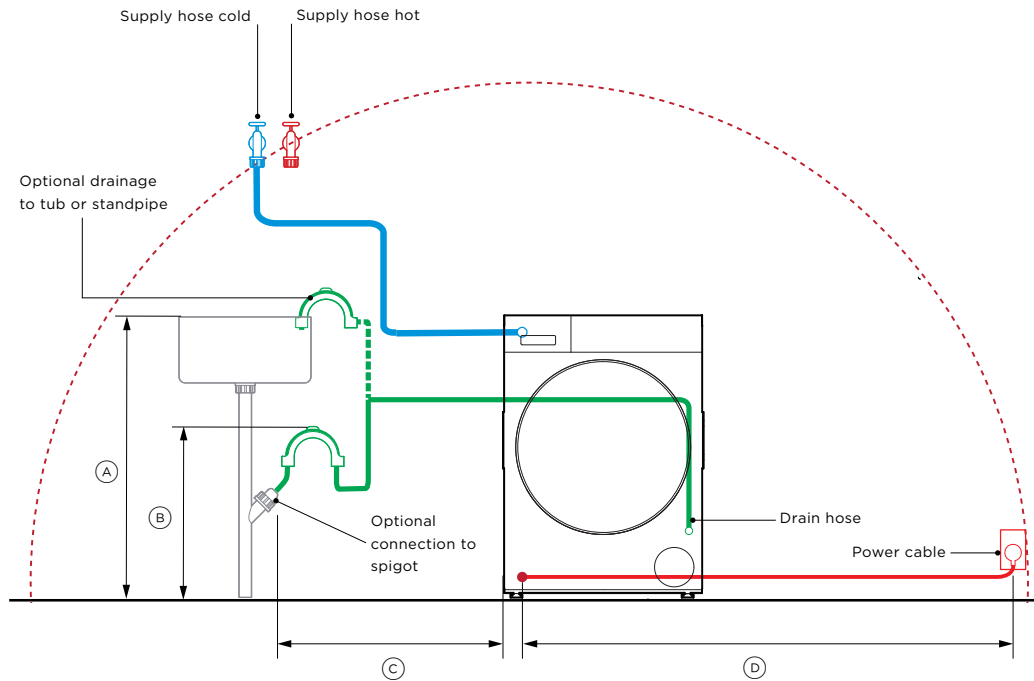

Model nos:

Front Loader Dryer - DH8060J5, DH9060J5

Product Dimensions

	mm
(A) Maximum standpipe or tub height	1000
With storage plinth	1200
(B) Minimum standpipe or tub height	600
With storage plinth	800
(C) Maximum distance to standpipe when located on the left	400
Maximum distance to standpipe when located on the right	1000
(D) Maximum power cord length to power outlet	1400

Specifications

Electrical

Supply	220 - 240 VAC, 50 Hz
Service	10 Amps
Outlet	3-prong grounding - type

Plumbing

Supply	Hose set provided
Pressure	Max. 1MPa (150psi) Min. 50KPa (7psi); Min 6 litres/min

NOTES:

Connections may be located in an adjacent cabinet to either side of the washer. Ensure power will remain accessible following install to allow access for any future product maintenance.

A washer and dryer without separate cold-water inlets shall be no more than 900mm apart in order to use steam cycles on the dryer.

Multiple product installation requires the design of water and power outlets according to local regulations.

----- INDICATES CABINETRY / PRODUCT DATUM

----- INDICATES CABINETRY CLEARANCES

----- INDICATES CUTOUT

IMPORTANT NOTE: Throughout this guide, dimensions may vary by ±2mm (1/16"). Please read the installation manual for detailed information on installing the product. For full installation instructions & specifications visit fisherpaykel.com

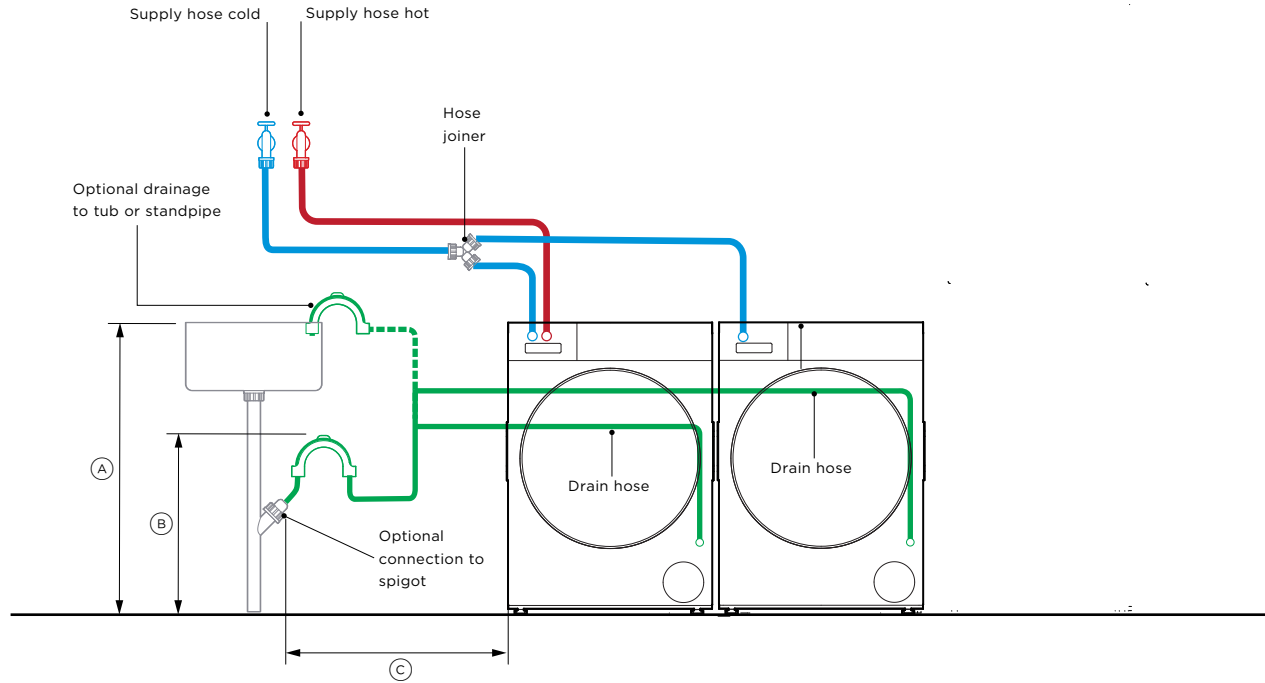

Model nos:

Front Loader Washing Machine - WH8060J5, WH9060J5
Heat Pump Dryer - DH8060J5, DH9060J5

Product Dimensions	mm
Ⓐ Maximum standpipe or tub height	1000
with storage plinth	1200
Ⓑ Minimum standpipe or tub height	600
with storage plinth	800
Ⓒ Maximum distance to standpipe from washer and dryer	400
Maximum distance to standpipe when located on the right	1000

Specifications (per product)

Electrical	
Supply	220 - 240 VAC, 50 Hz
Service	10 Amps
Outlet	3-prong grounding-type
Plumbing	
Supply	Hose set provided
Pressure	Max. 1MPa (150psi) Min. 50KPa (7psi); Min 6 litres/min

NOTES:

Connections may be located in an adjacent cabinet to either side of dryer

A washer and dryer without separate cold-water inlets shall be no more than 900mm apart.

Multiple product installation requires the design of water and power outlets according to local regulations.

----- INDICATES CABINETRY / PRODUCT DATUM

----- INDICATES CABINETRY CLEARANCES

----- INDICATES CUTOUT

IMPORTANT NOTE: Throughout this guide, dimensions may vary by ±2mm (1/16"). Please read the installation manual for detailed information on installing the product. For full installation instructions & specifications visit fisherpaykel.com

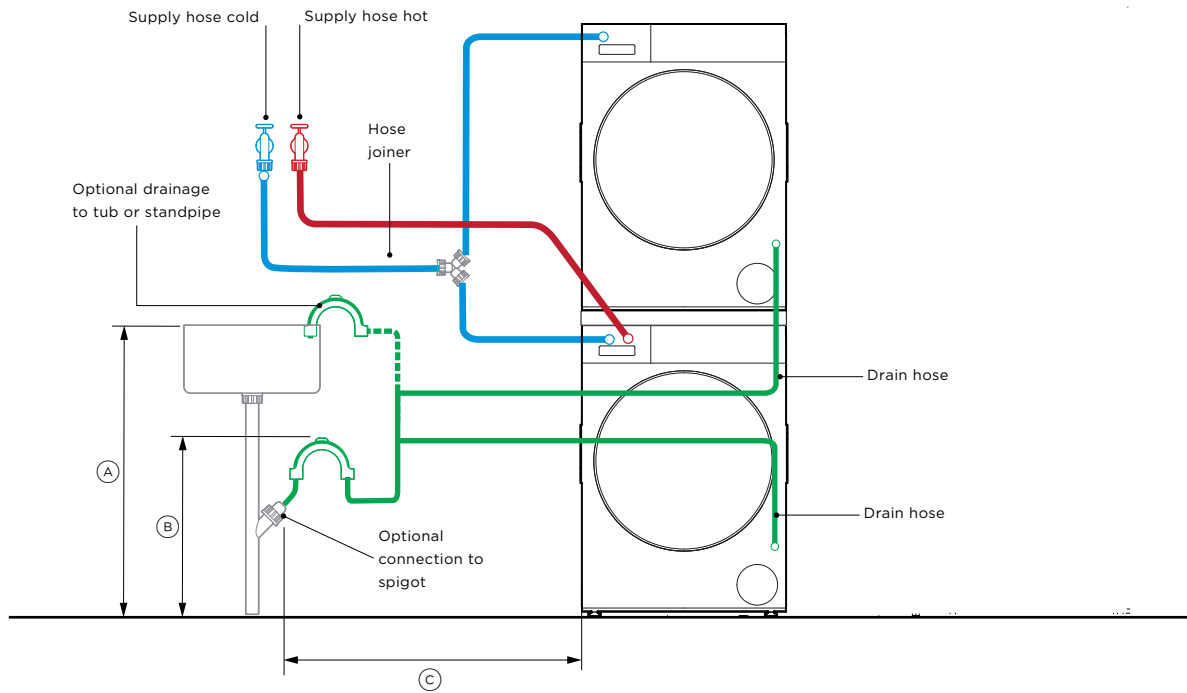

Model nos:

Front Loader Washing Machine - WH8060J5, WH9060J5
 Heat Pump Dryer - DH8060J5, DH9060J5
 Stacking kit: ASKS60W5

Product Dimensions

mm

Ⓐ	Maximum standpipe or tub height	1000
	with storage plinth	1200
Ⓑ	Minimum standpipe or tub height	600
	with storage plinth	800
Ⓒ	Maximum distance to standpipe from washer and dryer	400
	Maximum distance to standpipe when located on the right	1000

Specifications (per product)

Electrical

Supply	220 - 240 VAC, 50 Hz
Service	10 Amps
Outlet	3-prong grounding-type

Plumbing

Supply	Hose set provided
Pressure	Max. 1MPa (150psi) Min. 50KPa (7psi); Min 6 litres/min

NOTES:

Connections may be located in an adjacent cabinet to either side of dryer

A washer and dryer without separate cold-water inlets shall be no more than 900mm apart.

Multiple product installation requires the design of water and power outlets according to local regulations.

----- INDICATES CABINETRY / PRODUCT DATUM

----- INDICATES CABINETRY CLEARANCES

----- INDICATES CUTOUT

IMPORTANT NOTE: Throughout this guide, dimensions may vary by ±2mm (1/16"). Please read the installation manual for detailed information on installing the product. For full installation instructions & specifications visit fisherpaykel.com

