

Gas Range, 30", 4 Burners, LPG

Series 7 | Professional

Stainless Steel | LPG



Professional style and performance, with powerful burners delivering high heat or the most gentle simmer.

- Top burner heat of 19,000 BTU, for seriously fast boiling
- Convection oven with 4.6 cu ft total capacity
- Non-tip full-extension shelves for safe removal of hot dishes

DIMENSIONS

Height	35 3/4 - 36 3/4"
Width	29 7/8"
Depth	29 1/8"

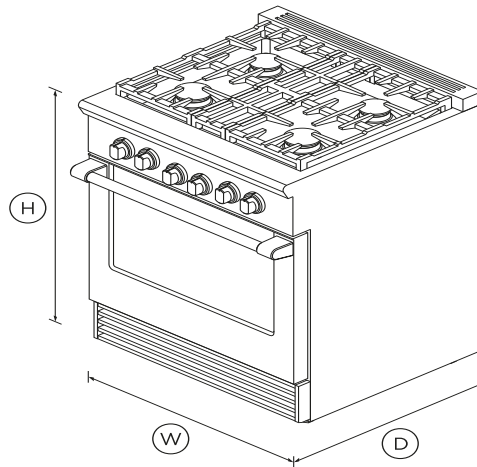

FEATURES & BENEFITS

Cooktop power

Sealed Dual Flow Burners™ deliver cooktop power up to 22,500 BTU (NG models) for seriously fast boiling right down to a precise 140°F full surface simmer with the gentlest of flames.

Total control

Precise control across high and low settings is delivered through the halo-illuminated cooktop dials. The ovens have true convection and electronic oven control for precise and consistent temperatures.

Easy to clean

A sealed cooktop surface coupled with a commercial-style stainless steel finish means your cooktop simply needs a quick wipe to keep it looking good as new.

Instant visibility

Control dials have halo-illumination glowing white – heating up; orange – temperature reached; red – self-cleaning mode. The oven is illuminated by two powerful incandescent lights.

COOKING FLEXIBILITY

The cooktop is designed for easy access to any burner with grates you can smoothly slide pots across. The oven is large enough to hold full size baking sheets.

Design quality

This range has been carefully crafted in every detail from performance to durability using quality materials.

SPECIFICATIONS

Accessories (sold separately)

Square handle option	AH-R30
----------------------	--------

Burner ratings

Maximum burner power	19000 BTU
Power back left	13000BTU
Power back right	13000BTU
Power front left	19000BTU
Power front right	15000BTU
Total cooktop power	60000 BTU

Capacity

Shelf positions	5
Shelf positions (main oven)	5

Controls

Electric circuit	3 wire
Metal illuminated dials	•

Gas Requirements

Fitting and pipe	½ NPT, min. ⅝" flex line
Supply Pressure (LPG)	11" to 14" W.C

Oven features

Auto re-ignition system	•
Broil pan	•
Electronic oven control	•
Full extension telescopic	•
Infrared Broiler	•
Internal light	•

Oven functions

Bake	•
Broil	•
Convection bake	•
Number of functions	3

Oven performance

Bake power	22,000 BTU
------------	-------------------

Power requirements

Amperage	15A
Rated current	15A
Supply frequency	60Hz

Product dimensions

Depth	29 1/8"
Depth (excluding handles)	29 1/8"
Height	35 3/4 - 36 3/4"
Width	29 7/8"

Rangetop features

Sealed range top	•
Vent trim included	•

Recommended Back Guards Ventilation

Combustible situation	BGRV2-3030H
Minimum CFM	600
Non combustible situation	BGRV2-3030 / BGRV2-1230
Recommended hood	HCB30-6_N (Professional

Safety

ADA compliant	•
Full extension telescopic	•

SKU	71357
-----	-------

The product dimensions and specifications in this page apply to the specific product and model. Under our policy of continuous improvement, these dimensions and specifications may change at any time. You should therefore check with Fisher & Paykel's Customer Care Centre to ensure this page correctly describes the model currently available. ? Fisher & Paykel Appliances Ltd 2020

Other product downloads available at fisherpaykel.com

- [↓](#) Service & Warranty
- [↓](#) User Guide EN
- [↓](#) Guide d'installation FR
- [↓](#) Installation Guide EN / Guide d'installation FR
- [↓](#) Data Sheet Gas Range
- [↓](#) Planning Guide Gas Range

**A PEACE OF MIND SALE****24 Hours 7 Days a Week Customer Support****T 1.888.936.7872 Wwww.fisherpaykel.com**