

# 48" Series 7 Professional 6 Burner + Griddle Gas Range, LPG

Professional



A striking addition to your kitchen, with six powerful gas burners and two gas ovens giving you a combined capacity of 7.7 cu ft.

- Top burner heat of 19,000 BTU, for seriously fast boiling
- Expansive 7.7 cu ft total oven capacity across two oven cavities
- Non-tip full-extension shelves in main cavity for safe removal of hot dishes

## DIMENSIONS

Height	35 3/4 - 36 3/4 "
Width	47 7/8 "
Depth	29 1/8 "

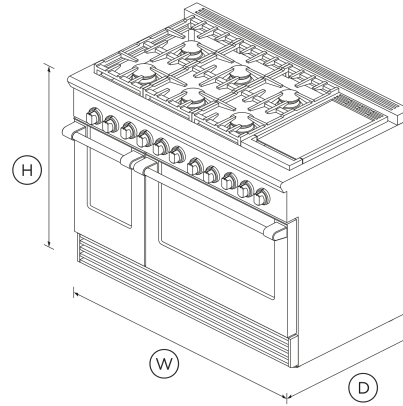

## FEATURES & BENEFITS

### Cooktop Power

Sealed Dual Flow Burners™ deliver cooktop power up to 23,500 BTU (NG models) for seriously fast boiling right down to a precise 140°F full surface simmer with the gentlest of flames.

### Total Control

Precise control across high and low settings is delivered through the halo-illuminated cooktop dials. The ovens have true convection and electronic oven control for precise and consistent temperatures.

### Instant Visibility

Control dials have halo-illumination glowing white - heating up; orange - temperature reached; red - self-cleaning mode. The oven is illuminated by two powerful incandescent lights.

### Easy To Clean

A sealed cooktop surface coupled with a commercial-style stainless steel finish means your cooktop simply needs a quick wipe to keep it looking good as new.

### Cooking Flexibility

The cooktop is designed for easy access to any burner with grates you can smoothly slide pots across. The oven is large enough to hold full size baking sheets.

### Design Quality

This range has been carefully crafted in every detail from performance to durability using quality materials.

## SPECIFICATIONS

### Accessories (sold separately)

Square handle option	AH-R48
----------------------	--------

### Burner ratings

Maximum burner power	19000 BTU
Power back centre	13000BTU
Power back left	13000BTU
Power back right	13000BTU
Power front centre	15000BTU
Power front left	19000BTU
Power front right	15000BTU
Power griddle	15000BTU
Total cooktop power	103000 BTU

**Capacity**

Shelf positions (main oven)	5
Shelf positions (second oven)	5

**Controls**

Electric circuit	3
Metal illuminated dials	•

**Gas Requirements**

Fitting and pipe	½ NPT, min. ⅝" flex line
Supply Pressure (LPG)	11" to 14" W.C

**Main oven features**

Broil pan	•
Electronic oven control	•
Full extension telescopic racks	•
Infrared broiler	•
Internal light	•

**Main oven functions**

Bake	•
Broil	•
Convection bake	•
Number of oven functions	3

**Oven features**

Auto re-ignition system	•
-------------------------	---

**Power requirements**

Amperage	15 A
Rated current	15 A
Supply frequency	60 Hz

**Product dimensions**

Depth	29 1/8 "
Depth (excluding handles)	29 1/8 "
Height	35 3/4 - 36 3/4 "
Width	47 7/8 "

**Rangetop features**

Sealed range top	•
Vent trim included	•

**Recommended Back Guards Ventilation**

Combustible situation	BGRV2-3048H
Minimum CFM	1200
Non combustibile situation	BGRV2-3048 / BGRV2-1248
Recommended hood	HCB48-12_N (48" Professional Range Hood, Dual Blower)

**Safety**

ADA compliant	•
Full extension telescopic sliding shelves	•

**Secondary oven features**

¾ Extension racks	2
Electronic oven control	•
Internal light	•

**Secondary oven functions**

Bake	•
Number of secondary oven functions	2
Proof	•

SKU 71347

The product dimensions and specifications in this page apply to the specific product and model. Under our policy of continuous improvement, these dimensions and specifications may change at any time. You should therefore check with Fisher & Paykel's Customer Care Centre to ensure this page correctly describes the model currently available. © Fisher & Paykel Appliances Ltd 2020

**Other product downloads available at fisherpaykel.com**

- [↓](#) DWG
- [↓](#) DXF
- [↓](#) Data Sheet (English)
- [↓](#) Installation Guide (English, Canadian French)
- [↓](#) Planning Guide (English)

- [↓](#) Right To Repair Declaration (English, Canadian French)
- [↓](#) User Guide (English)
- [↓](#) User Guide (Canadian French)

**Where applicable:**

All appliances use energy, and energy usage typically generates carbon emissions. **Fisher & Paykel Appliances' In-use Energy Carbon Emissions Estimate** indicates carbon emissions from a product's in-use energy. This is calculated either annually or per cycle, using the product's market-specific energy label energy consumption data multiplied by the carbon emissions factor for energy in your country or region.

Our In-use Energy Carbon Emissions Estimate is designed to assist customers in making informed purchasing decisions when comparing different Fisher & Paykel products. For example, a heat pump dryer typically has a lower In-use Energy Carbon Emissions Estimate than a vented dryer.



**A PEACE OF MIND SALE**  
24 Hours 7 Days a Week Customer Support  
T 1.888.936.7872 W [www.fisherpaykel.com](http://www.fisherpaykel.com)