

413L Series 5 Refrigerator Freezer

Series 5 | Contemporary

White | Right Hinge

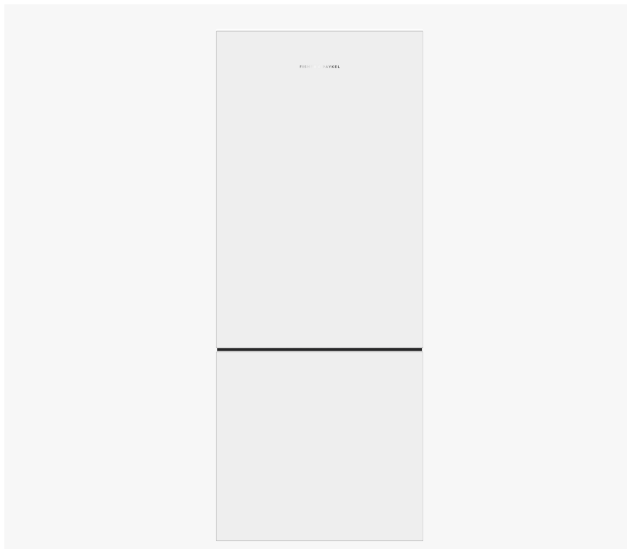

With Contemporary styling and generous, flexible storage for all your chilled and frozen foods.

- ActiveSmart™ technology helps keep food fresher for longer by constantly maintaining the ideal temperature.
- Spacious bottom freezer with easy-slide internal drawers to separate storage

DIMENSIONS

Height	1720 mm
Width	680 mm
Depth	695 mm

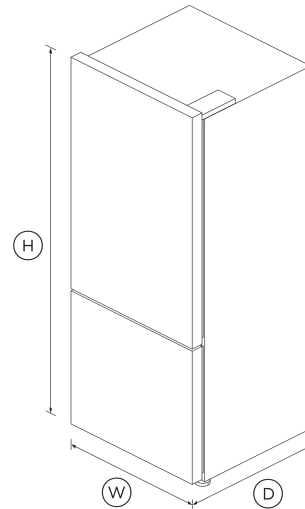

SPECIFICATIONS

Capacity	
Total gross capacity	442 L
Volume	413 L
Volume freezer	119 L
Volume refrigerator	294 L

Consumption	
Energy rating	3 star
Energy usage	428kWh/year

In-use energy carbon emissions estimate **261.2kgCO2e/year**

Features

Adjustable door shelves	4
Adjustable glass shelves	4
Covered door shelves	2
Door alarm	•
Front levelling feet	•
Fruit and vegetable bins	2
LED lighting	•
Rear rollers	•
Single bottle holders	2
SmartTouch control panel	•

Freezer Features

Bottle chill	•
Door alarm	•
Fast freeze	•
Ice trays	2
Large plastic bins	•
Slide Out Pastry Tray	•
Small plastic bins	•

Performance

ActiveSmart™ Foodcare	•
Adaptive defrost	•
Frost free freezer	•
Humidity control system	•

Inverter controlled compressor •

Product dimensions

Depth	695 mm
Height	1720 mm
Height to top of cabinet	1720 mm
Minimum air clearance - at rear	30 mm
Minimum air clearance - each side	20 mm
Minimum air clearance - on top	50 mm
Width	680 mm

Variable Temp Compartment

Bottle chill mode •

Warranty

Parts and labour	2 years
Sealed system parts only	additional 3 years

SKU 26377

The product dimensions and specifications in this page apply to the specific product and model. Under our policy of continuous improvement, these dimensions and specifications may change at any time. You should therefore check with Fisher & Paykel's Customer Care Centre to ensure this page correctly describes the model currently available. © Fisher & Paykel Appliances Ltd 2020

Other product downloads available at fisherpaykel.com

- [↓ 2D-DWG Freestanding Refrigerator Freezer](#)
- [↓ 2D-DXF Freestanding Refrigerator Freezer](#)
- [↓ Data Sheet Freestanding Refrigerator Freezer](#)
- [↓ Energy Label](#)
- [↓ Energy Label](#)
- [↓ Service & Warranty](#)
- [↓ Installation Guide](#)
- [↓ User & Installation Guide ActiveSmart Refrigerator](#)

Where applicable:

All appliances use energy, and energy usage typically generates carbon emissions. **Fisher & Paykel Appliances' In-use Energy Carbon Emissions Estimate** indicates carbon emissions from a product's in-use energy. This is calculated either annually or per cycle, using the product's market-specific energy label energy consumption data multiplied by the carbon emissions factor for energy in your country or region.

Our In-use Energy Carbon Emissions Estimate is designed to assist customers in making informed purchasing decisions when comparing different Fisher & Paykel products. For example, a heat pump dryer typically has a lower In-use Energy Carbon Emissions Estimate than a vented dryer.



A PEACE OF MIND SALE
24 Hours 7 Days a Week Customer Support
 T 1300 650 590 W www.fisherpaykel.com