

Freestanding Refrigerator Freezer, 79cm, 491L

Series 5 | Contemporary

Stainless Steel | Right Hinge



With ample storage and a stylish stainless steel finish, for a timeless look.

- ActiveSmart™ technology helps keep food fresher for longer by constantly maintaining the ideal temperature.
- Spacious bottom freezer with full extension drawer gives easy access to frozen goods.

DIMENSIONS

Height	1715mm
Width	790mm
Depth	695mm

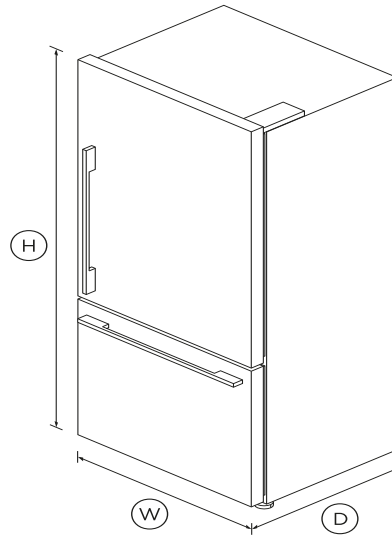

FEATURES & BENEFITS

Activesmart™ Foodcare

ActiveSmart™ Foodcare learns how you live. It's technology which understands how you use your refrigerator and adjusts temperature, airflow and humidity inside to help keep food fresher for longer.

Design quality

Our refrigerators are designed and built using quality materials. We use real stainless steel, and solid glass for shelving.

CLEVER ENERGY

Your fridge adapts to daily use by cooling and defrosting only when needed. This means your fridge uses the energy it needs without compromising on food care.

Simple storage

This refrigerator is designed to make it simple for you to store, access and remove food. Storage bins give you full access inside when they're pulled open and can be easily removed to clean. Our flexible shelving also gives you more storage options.

Easy Cleaning

No more permanent dirty marks with our EZKleen feature for stainless steel refrigerators. Anti-fingerprint coating means you simply wipe clean any marks. Spill-safe secure glass shelves easily capture any drips or leaks.

Humidity control

Your fruit and veges need different environments. The humidity control slides in each storage bin create a microclimate that helps keep food fresher for longer.

SPECIFICATIONS

Capacity

Volume	491L
Volume freezer	143L
Volume refrigerator	348L

Consumption

Energy rating	Grade 2
---------------	---------

Features

Adjustable door shelves	4
Adjustable glass shelves	4
Covered door shelves	2

Door alarm	•
Front levelling feet	•
Fruit and vegetable bins	2
LED lighting	•
Single bottle holders	4
SmartTouch control panel	•

Height to top of cabinet	1715mm
Width	790mm

Warranty

Parts and labour	1 year
Sealed system parts only	3 years



A PEACE OF MIND SALE

24 Hours 7 Days a Week Customer Support

T 400 640 8777 **W**www.fisherpaykel.com

Freezer Features

Bottle chill	•
Door alarm	•
Fast freeze	•
Ice bin and scoop	•
Large plastic bins	•
Small plastic bins	•

SKU	26482
-----	-------

The product dimensions and specifications in this page apply to the specific product and model. Under our policy of continuous improvement, these dimensions and specifications may change at any time. You should therefore check with Fisher & Paykel's Customer Care Centre to ensure this page correctly describes the model currently available. ? Fisher & Paykel Appliances Ltd 2020

Performance

ActiveSmart Foodcare	•
Adaptive defrost	•
Frost free freezer	•
Humidity control system	•
Inverter controlled compressor	•
R600a refrigerant	•

Power requirements

Connection power	240W
Supply voltage	220 - 240V

Product dimensions

Depth	695mm
Height	1715mm