

# Oven, 60cm, 7 Function

Series 5 | Contemporary

Stainless Steel



With contemporary styling and clean lines in glass and steel, this built-in oven complements the style and elegance of any modern kitchen.

- 55L total capacity
- Seven oven functions including Pastry Bake

## DIMENSIONS

Height	458mm
Width	597mm
Depth	565mm

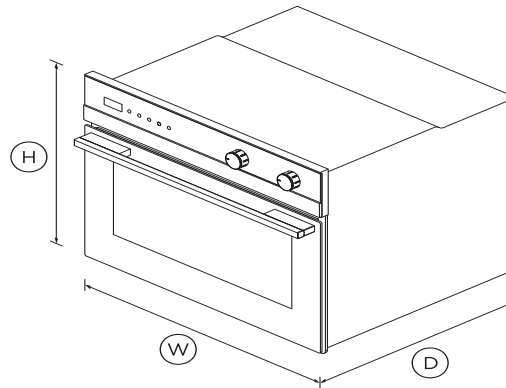

## SPECIFICATIONS

### Accessories

Catalytic panels	•
Grill rack	1 set
Roasting dish	1
Step down wire shelf	1
Telescopic sliding runners	1 set

### Capacity

Shelf positions	4
Total capacity	55L
Usable capacity	45L

### Cleaning

Acid resistant graphite enamel	•
Drop down grill element	•
Removable oven door inner	•
Removable shelf runners	•

### Controls

Automatic cooking/minute	•
Electronic capacitive touch	•
Electronic clock	•
Halogen lights	•

### Functions

Bake	•
Classic bake	•
Fan bake	•
Fan forced	•
Fan grill	•
Grill	•
Number of functions	7
Pastry Bake	•

### Performance

AeroTech™ technology	•
Grill power	3000W
Whisper quiet cooking	•

---

**Power requirements**Amperage **15A**

---

**Product dimensions**Depth **565mm**Height **458mm**Width **597mm**

---

**Safety**

- Balanced oven door •
  - CoolTouch door •
  - Non-tip shelves •
- 

**Warranty**Parts and labour **2 years**

---

SKU **81498**

---

making informed purchasing decisions when comparing different Fisher & Paykel products. For example, a heat pump dryer typically has a lower In-use Energy Carbon Emissions Estimate than a vented dryer.

---

**Other product downloads available at fisherpaykel.com**

- [↓](#) Service & Warranty
- [↓](#) User Guide Wall Oven
- [↓](#) Installation Guide Built-In Oven
- [↓](#) Data Sheet Oven

**A PEACE OF MIND SALE****24 Hours 7 Days a Week Customer Support****T 0800 372 273 W www.fisherpaykel.com**

The product dimensions and specifications in this page apply to the specific product and model. Under our policy of continuous improvement, these dimensions and specifications may change at any time. You should therefore check with Fisher & Paykel's Customer Care Centre to ensure this page correctly describes the model currently available. Fisher & Paykel Appliances Ltd 2020

**Where applicable:**

All appliances use energy, and energy usage typically generates carbon emissions. **Fisher & Paykel Appliances' In-use Energy Carbon Emissions Estimate** indicates carbon emissions from a product's in-use energy. This is calculated either annually or per cycle, using the product's market-specific energy label energy consumption data multiplied by the carbon emissions factor for energy in your country or region.

Our In-use Energy Carbon Emissions Estimate is designed to assist customers in